

Movement by Perfection



Fans and Control Technology

for Agriculture
03/2016 Edition

The Royal League in ventilation, control and drive technology

Using air intelligently

Air is always there but is hardly perceived consciously. Directing air in a specific form of movement is the competence of ZIEHL-ABEGG. As the world's leading provider of fans with adapted control technology, ZIEHL-ABEGG relies on the efficiency and reliability of the products. With the trailblazing solutions from ZIEHL-ABEGG, customers use air and energy optimally for their individual requirements.

FANselect The fan selection program

With the first fully comprehensive certified fan selection program FANselect the customer can find the optimum fans and system components for his needs conveniently, precisely and quickly. The specified values conform to reality. They are determined in the ZIEHL-ABEGG InVent technology centre which houses the world's biggest combined air and noise test benches of the ventilation system branch. More information on www.fanselect.info

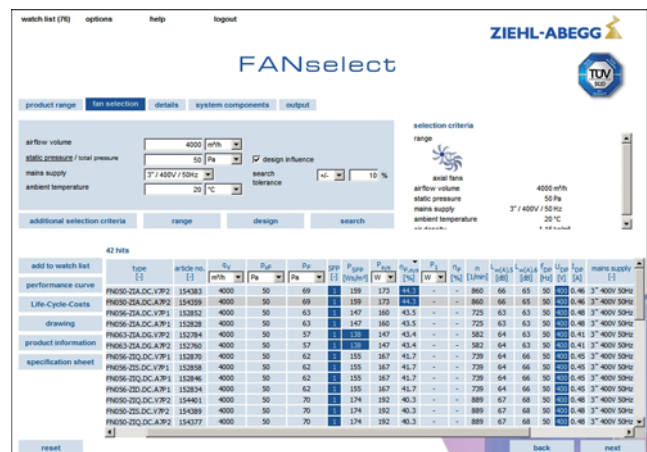





Other catalogues

In the ZIEHL-ABEGG catalogues, the reader can find out all about ZIEHL-ABEGG fans, motors and the perfectly adapted control technology. All the catalogues are available on www.ziehl-abegg.de website in the "Download" section.



Contents

The ZIEHL-ABEGG Company		Page 4	Information
Low pressure fans		Page 26	Low pressure
High pressure fans		Page 80	High pressure
System components		Page 110	System components
Control technology		Page 126	Control technology
General notes		Page 164	Appendix



ZIEHL-ABEGG

Die Königsklasse

der Lufttechnik,
Regeltechnik und Antriebstechnik

Radialventilator
ZAmid®Technologie



Welcome to the world of ZIEHL-ABEGG

Top technology "Made by ZIEHL-ABEGG"

A pioneering spirit and the courage of innovation were the driving forces behind Emil Ziehl's development of his first external rotor motor over a hundred years ago. With this he laid the corner stone for the success story of ZIEHL-ABEGG in 1910. Today, the family company ZIEHL-ABEGG, with its headquarters in Künzelsau, develops, produces and sells high quality, high-tech components: Fans, special electric motors and their perfectly adapted, state-of-the-art control technology. Still today, Emil Ziehl's pioneering spirit is the motivator for making good even better and finding new, revolutionary solutions. ZIEHL-ABEGG is based in Southern Germany but is at home all over the world. At the world-wide production and sales sites, thousands of employees develop, produce and sell technical, economical and ecological progress.

Welcome to the world of ventilation, control and drive technology.

Your contact into the world of ZIEHL-ABEGG

Would you like to learn more about the company ZIEHL-ABEGG, its products and applications? Your current direct contact partners can always be found at www.ziehl-abegg.com



One-stop expertise

Fan, motor and control technology

Whether air conditioning, drying, cooling or ventilating, the efficient fans with adapted drive and control technology from ZIEHL-ABEGG cope with these tasks safely and reliably. Individual and also complex customer requirements are welcome challenges.

At ZIEHL-ABEGG headquarters in Künzelsau, more than 300 engineers and technicians concentrate daily on finding the best solution. In the InVent, one of the most modern technology centres of its kind, they work on the innovations of the future. Their ideas are put into practice by excellently trained specialists on state-of-the-art plants. The production as well as all processes are accompanied by prudent quality management. ZIEHL-ABEGG products are subjected to rigorous testing before being put into operation at the customer's. On the world's biggest air and noise test bench, vibrations and external noises are eliminated and thus ensure top class fan measurements in accordance with ISO and DIN. The result is top class products and services which are marked by the seals "Premium Quality" and "Premium Efficiency".

The world's biggest and most modern test bench for fans at the headquarters in Künzelsau

State-of-the-art production lines to meet the highest demands

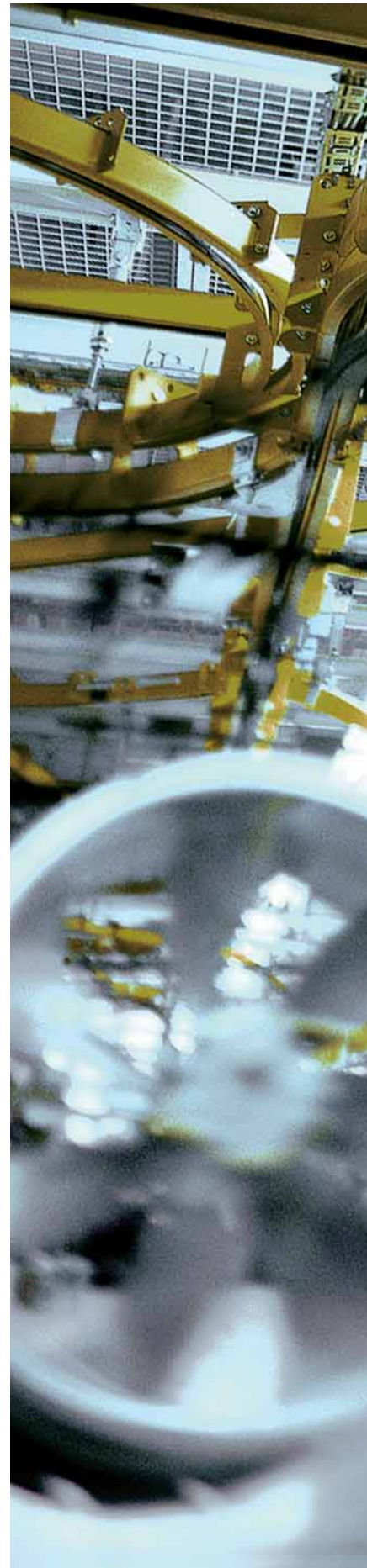



Information

Low pressure

High pressure

System components

Control technology

Appendix

EC fans of the Royal League

Quiet, efficient, environmentally friendly

EC fans from ZIEHL-ABEGG unite state-of-the-art motor technology with innovative aerodynamics. This symbiosis scores high marks by merging revolutionary ECblue technology with premium fans. The result is efficiency and absolutely economical operation. The new generation of axial fans heads the ECblue technology: The FE2owlet has biologically designed rotor blades for almost noiseless conveyance of air. Moreover, the FE2owletbio is made from 100% recyclable bio-polyamides. Further highlights of material development at ZIEHL-ABEGG are shown in the Cpro centrifugal fan with the new ZAmid® technology. The new high performance composite material is as hard as steel but only half the weight. This is kind on the bearings and saves energy. Greater efficiency also comes from the newly developed blade geometry in the centrifugal impellers which has only become possible thanks to the innovative composite material. In standard application, EC-fans achieve maximum volume flows with extraordinary efficiency despite their low noise. Together with the ECblue motors, ZIEHL-ABEGG fans achieve a dynamic response which makes them absolute leaders in environmental friendliness and efficiency.

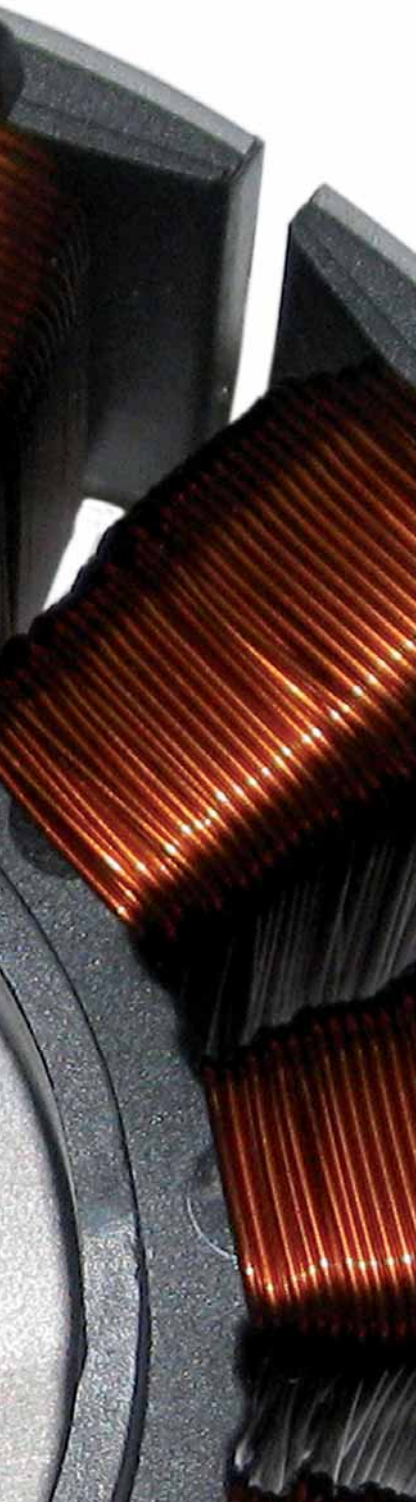

ECblue motor technology





Maximum efficiency and minimum consumption
ECblue with the latest **ZAmid**® Technology
Radial fans sector



Unique bionic profile FE2owlet,
combined with ECblue technology



Information

Low pressure

High pressure

System
components

Control
technology

Appendix

AC-fans of the Royal League

Strong, robust, extraordinary

In all applications in which the material is exposed to immense stress, the AC fans from ZIEHL-ABEGG demonstrate their quality and ability. Their solid components and robust design and technology are able to withstand even the greatest stresses. The fans are therefore used in many different areas of industry or agriculture - wherever absolute insensitivity and stability is important.

The high quality motor technology is the result of decades of experience at ZIEHL-ABEGG. Intelligently used components such as the Fcontrol frequency inverter make them environmentally friendly and efficient key players. Maintenance-free and extraordinarily performant, AC fans from ZIEHL-ABEGG are a safe and rewarding investment.

AC motor technology, robust in operation



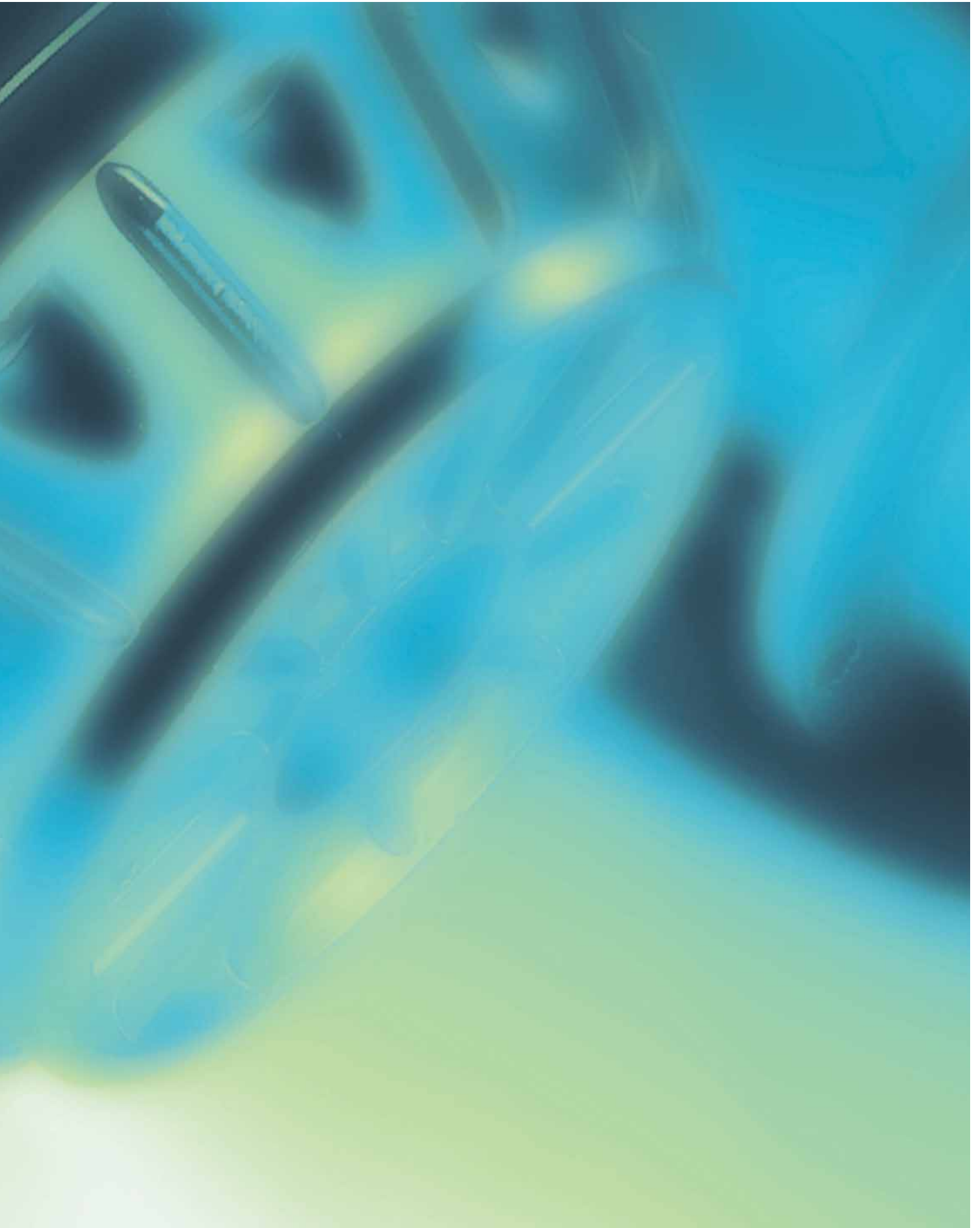

Information

Low pressure

High pressure

System components

Control technology

Appendix

Expertise in ventilation

ErP directive

With the Kyoto protocol, the European Union pledged to reduce CO₂ emissions by at least 20 per cent by the year 2020. One measure for achieving this is the ErP directive for improved energy efficiency and general environmental compatibility of electrical equipment – also known in Germany as the Eco Design directive. It supports a resource-friendly and energy-efficient product design. With the implementation of the ErP directive, stricter efficiency requirements for fans in the output range from 125 W to 500 kW apply since 2013 and 2015 in two stages. A further stage is planned for 2020. Energy efficiency is thus given the same standing as the compliance with the low voltage or EMC directive. The system efficiency requirement is a prerequisite for a CE mark and is thus essential for a product to be used in EU member states. An own label as for refrigerators is not planned for fans because the fan manufacturers do not usually have any influence on the installation conditions.

Products for use in EU countries and world-wide markets are listed in this catalogue. For the fans for the EU countries, the respective ErP identification is included directly in the description of the fan.



The **European Ventilation Industry Association (EVIA)** represents the European ventilation industry with national and European institutions.

The EVIA is the key platform for fan manufacturers and is their interface to politicians, decision-makers in the European Union, and other associations that use fans in their products. The EVIA supports the use of high efficiency fans in Europe to implement the EU targets for increased efficiency.

ZIEHL-ABEGG played a leading role in its foundation and supports the EVIA with active involvement in its working groups. ZIEHL-ABEGG also provides the chairman.



Axial fans for agriculture

Bearings

Grooved ball bearing with non-standard grease, maintenance-free and low-noise design.

Corrosion protection

Fan made of die-cast aluminium, wall ring plate in sizes 040/045/050/063/091 made from impact-resistant plastic (PS). All other sizes made from galvanised thin sheet metal, coated black or powder coated.

The ZAplus nozzle is made from a high-performance composite material.

Balance quality

G 6.3 as per **DIN ISO 1940** section 1

Safety requirements

The fans contained in this catalogue are designed to be used as built-in fans for animal housing complexes. If the fan cannot be accessed as a result of the installation conditions, e.g. due to the installation height or installation in a vent chimney, no additional guard grille needs to be installed. Safety margins as per **DIN EN ISO 13857** must be observed.

Fans without guard grille may only be used if the installation height (danger area) above the reference plane is greater than or equal to 2.7 m. If the fan is in the danger area, the manufacturer of the complete system or the operator must ensure that a hazard is prevented on both the suction and pressure sides using a protective system as per **DIN EN ISO 13857**.

Electrical connection

ECblue - low pressure

Connection cable combined with shielded control line
FE2owlet FN040/45 and FFowlet up to and including size 630 have a cable length of 1.20 m.

FFowlet from size 710 to 910 have a cable length of 1.50 m.

ECblue - high pressure

FE2owlet fans from size 630 have a terminal box.

AC motors

Are connected to the motor's terminal box.

Cleaning

The fan must be inspected and cleaned of deposits regularly in order to prevent imbalance and stop the condensation holes becoming clogged with contamination.

Ensure that water is prevented from accessing the inside of the motor and the electronics (e.g. through direct contact with seals or motor openings), observe the protection class (IP).

No warranty claim or liability for corrosion or coating adhesion can be accepted in the event of improper cleaning of coated/uncoated fans.

To prevent the accumulation of moisture in the motor, the fan must be operated at 80 to 100% of its maximum speed for at least 1 hour before cleaning!

After the cleaning process, the fan must be operated at 80 to 100% of its maximum speed for at least 2 hours to dry.

Temperatures

ZIEHL-ABEGG fans can be operated at ambient temperatures down to $-40^{\circ}\text{C}^{***}$ when used properly. When used below -10°C and max. $-40^{\circ}\text{C}^{***}$ it is a prerequisite that no unusual external influences such as abrupt mechanical stresses affect the material. For 1~ motors with a service capacitor down to -25°C observe the maximum ambient temperature stated on the type label.

******* Continuous operation with occasional starts (S1) according to **DIN EN 60034-1:2011-02**. Occasional starting between -40°C and -25°C is permissible. Continuous operation below -25°C only with special bearings for refrigeration applications on request.

Airflow direction A

Sucking over stator



Airflow direction V

Blowing over stator

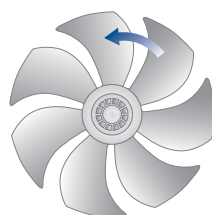

KL2065

Direction of rotation counter clockwise looking at the rotor

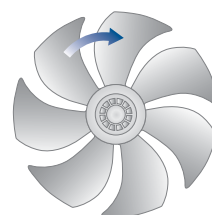

KL2064

Direction of rotation clockwise looking at the rotor

Axial fans with external rotor motor - ECblue

The fan for animal housing, with direct drive through ECblue external rotor motor and an integrated EC controller

- High efficiency across the entire speed range, resulting in lower operating costs
- Low noise
- Simple installation
- Compact design thanks to high power density
- Complies with valid EMC specifications for households and industry
- All radio interference functions integrated in device
- Maximum speed independent of power frequency
- Universal activation (PWM or analogue signal)
- Wide voltage range 3~ 380V-480V or 1~ 200-277V

Energy saving

The ECblue is a fan/controller system with extremely low energy-consumption. The EC controller integrated in the fan enables new control options compared to existing systems.

Application example

In ventilation systems, the maximum possible air handling capacity is only required for temperature control when the outdoor temperature is high. Speedcontrolled fans used here are mostly operated along the system characteristic at reduced speed. The minimum speed results from the animals' fresh air requirement.

Low power consumption and the resulting higher level of efficiency at partial load is crucial in making the system cost-effective (chart 1). Consumption of electrical energy in EC drives, particularly in the often-used medium speed range, is much lower than in the 1~ asynchronous, phase-controlled drives commonly used in animal house ventilation (chart 2). The higher investment costs associated with EC drives are amortised within 2 - 3 years, thanks to the significantly lower operating costs.

The cost benefit across the full service life of the fan is over 40% (chart 3).

Using EC drives, the given temperature value can be maintained much more precisely, as the speed adjusts proportionally to the modulation level. Phasecontrolled 1~ asynchronous drives have a non-linear behaviour here.

Control variants

Speed controllers with 0-10 V or PWM input
ECblue fans can be operated with speed control via a 0-10 V or PWM input signal. The fan speed is therefore 0 - 100 %. The speed is monitored and adjusted, which can for example ensure that the fan starts in the event of contamination and which thanks to the proportionality (e.g. setpoint 5V corresponds to precisely half the maximum speed) guarantees a very good temperature consistency in the animal housing.

Fan and speed disturbances are returned via an isolated relay (break contact).

The user can switch between controlled operation and maximum speed via a separate control cable (100 % function), in order to ensure ventilation in the event that the controller fails.

If you would like to retrofit an existing system with ECblue, the easiest way is to only replace the fans. The existing controllers can control the ECblue via a 0-10 V or PWM (pulse-width modulated) signal to set speed.

Chart 1

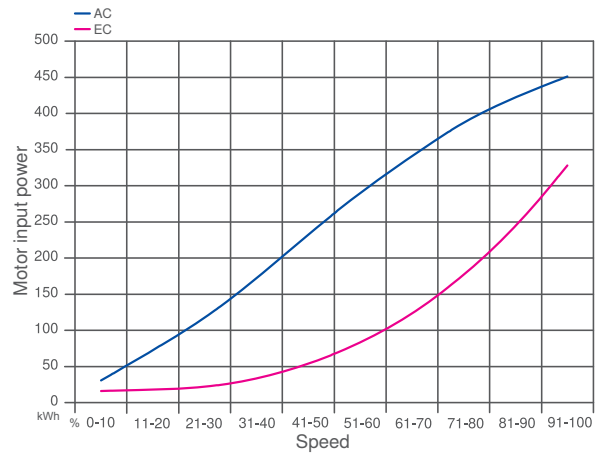

Chart 2

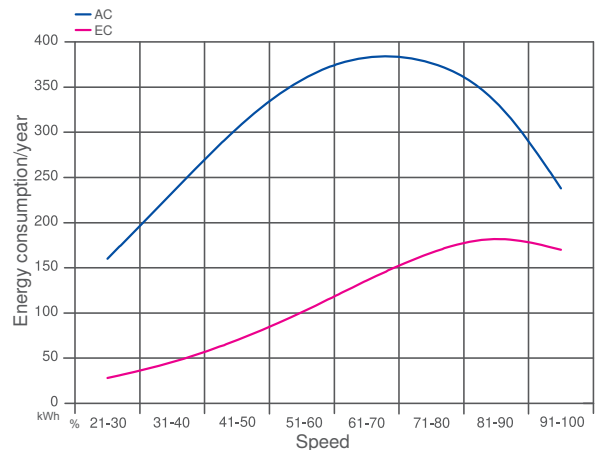
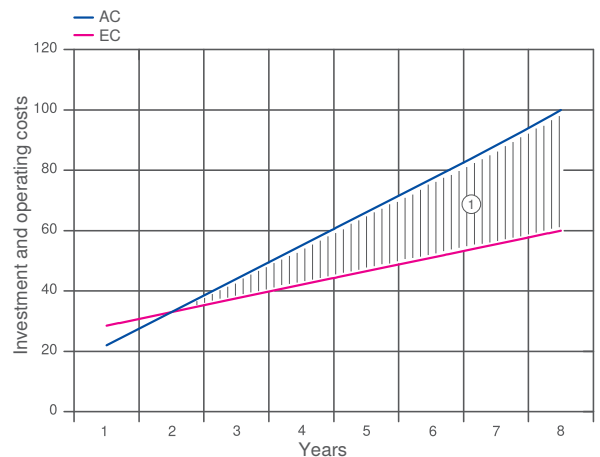

Chart 3



① High cost saving after a very short time



Information

Low pressure

High pressure

System components

Control technology

Appendix



Technical description

FFowlet

Product specification

Fluted, sickle-shaped blades based on bionic insights. Available dimensions 500 - 910 mm, volume flow rates up to 24.500 m³/h and static pressure increase up to 150 Pa.

Properties and special features

- Specially designed for applications with low pressure loss
- Optimised for agricultural applications
- Protection class IP55 and coated blade for extreme conditions
- Low operating costs due to optimum efficiency with minimum noise emissions as a result of bionic blade design
- High flexibility due to 100% speed controlled volume flow rate
- Very smooth running and high durability due to dynamic balancing on 2 levels
- Compact dimensions for every installation situation
- Meets ErP Directive 2015
- Numerous approvals (incl. UL, CCC, CE)
- Itemised cables for fast commissioning

Motor concepts

External rotor motors

- ECblue EC technology with integrated controller matched to the fan
- AC technology



FFowlet with ZAplus

Product specification

Optimised full nozzle with guide vane, motor suspension, and short diffuser. Fluted, sickle-shaped blades based on bionic insights. Available dimensions 630 - 910 mm, volume flow rates up to 24.000 m³/h and static pressure increase up to 160 Pa.

Properties and special features

- Intelligent ventilation system with built-in efficiency guarantee
- Specially designed for applications with low pressure loss
- Optimised for agricultural applications
- High degree of corrosion protection with corrosion-free nozzles made of high-performance composite material
- Coated blade for extreme conditions
- Extremely low operating costs due to optimum efficiency with minimum noise emissions as a result of bionic blade design
- High flexibility due to 100% speed controlled volume flow rate
- Very smooth running and high durability due to dynamic balancing on 2 levels
- Compact dimensions for every installation situation
- Meets ErP Directive 2015
- Numerous approvals (incl. UL, CCC, CE)

Motor concepts

External rotor motors

- ECblue EC technology: with integrated controller matched to the fan
- AC technology



Information

Low pressure

High pressure

System components

Control technology

Appendix

Technical description

FE2owlet

Product specification

Fluted, sickle-shaped blades based on bionic insights. Available sizes 250 - 1,250 mm, volume flow rates up to 53,750 m³/h and static pressure increase up to 418 Pa.

Properties and special features

- Low operating costs due to optimum efficiency with minimum noise levels
- High flexibility due to 100% speed controllable volume flow rate
- Very smooth running and long service life due to dynamic balancing in two levels
- Compact dimensions for every installation situation
- Compliant with ERP directive 2015
- Numerous approvals (incl. VDE, UL, CCC, CE)

Motor concepts

External rotor motors

- ECblue EC technology with integrated controller matched to the fan
- AC technology

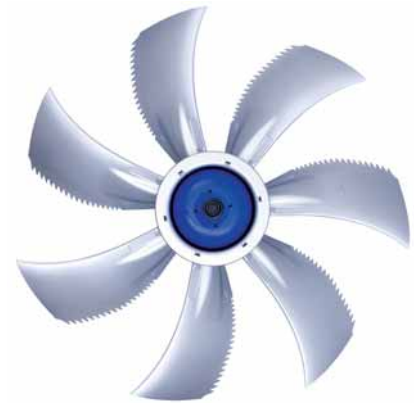

FE2owlet with ZAplus

Product specification

Optimised full bell mouth with guiding vane, motor suspension and short diffusor. Fluted, sickle-shaped blades based on bionic insights. Available sizes 630 - 910 mm, volume flow rates up to 36,500 m³/h and static pressure increase up to 475 Pa.

Properties and special features

- Intelligent ventilation system with built-in efficiency guarantee
- Lowest operating costs due to optimum efficiency with minimum noise levels due to bionic blade design and aerodynamically optimised ZAplus nozzle
- High level of flexibility due to 100% speed controllable volume flow rate
- High corrosion protection with corrosion-free nozzle made of high performance composite material
- Very smooth running and long service life due to dynamic balancing in two levels
- Air handling capacity possible with diffusor kit (ZAplus+)
- Minimal handling effort as no packaging needed
- Compliant with ERP directive 2015
- Numerous approvals (incl. VDE, UL, CCC, CE)

Motor concepts

External rotor motors

- ECblue EC technology with integrated controller matched to the fan
- AC technology



Information

Low pressure

High pressure

System components

Control technology

Appendix

Technical description

FC

Product specification

Fluted aluminium die-cast blade for use in aerodynamically designed air duct systems, such as full nozzles and pipe installation. Available dimensions 350 – 910 mm, volume flow rates up to 37.000 m³/h and static pressure increase up to 300 Pa.

Properties and special features

- High flexibility due to 100% speed controlled volume flow rate
- Compromise between energy efficiency and investment costs
- Very smooth running and high durability due to dynamic balancing on 2 levels
- Meets ErP Directive 2015
- Numerous approvals (incl. VDE, UL, CCC, CE)

Motor concepts

External rotor motors

- AC technology



FC with ZAplus

Produktspezifikation

Optimised full nozzle with guide vane, motor suspension, and short diffuser. Fluted aluminium die-cast blade in dimension 500 mm, volume flow rates up to 7.800 m³/h and static pressure increase up to 110 Pa.

Properties and special features

- High flexibility due to 100% speed controlled volume flow rate
- High degree of corrosion protection with corrosion-free nozzles made of high-performance composite material
- Compromise between energy efficiency and investment costs
- Compact dimensions for every installation situation
- Very smooth running and high durability due to dynamic balancing on 2 levels
- Meets ErP Directive 2015
- Numerous approvals (incl. VDE, UL, CCC, CE)

Motor concepts

External rotor motors

- AC technology



Information

Low pressure

High pressure

System components

Control technology

Appendix

Type key

Necessary ordering information

Type and Art. no.

Example

Type: FN050-4EQ.4I.A7P1
Art. no.: 140084

Example

FN 050 - 4 E Q . 4I . A 7 P 1

Axial fan	
	FN
	ZN
	and so on

Size code	
Impeller diameter 450 mm	045
Impeller diameter 500 mm	050
	and so on

Number of poles	
2-pole	2
4 pole	4
4-4 pole	V
6 pole	6
6-6 pole	S
8 pole	8
8-8 pole	A
10 pole	Z
10-10 pole	M
12-12 pole	N

Type of current	
three phase alternating current	D
single phase alternating current	E
External rotor EC motor with controller	I

Fan design	
without mounting parts	A
Full bell mouth	
rectangular	Q
round	L
pipe socket	
with one flange	H
flange ring	
with two flanges	F
Axial screwed suspension	
for full bell mouth Q and L / conveying direction A	D
for short bell mouth E / conveying direction A	W
for short bell mouth E / conveying direction V	K
On nozzle flange for pipe fitting H for full nozzle Q or L / airflow direction V	I
Centrifugal screwed suspension	
On outer diameter for full nozzle Q or L / airflow direction V	S
Chimney suspension	T

Motor	
Airflow direction	
Sucking over stator	A
Blowing over stator	V

Number of blades	
Blade angle	
Blade index	



Selection programme FANselect

The world's best selection program for fans

The screenshot shows the FANselect web application interface. At the top, there are navigation tabs: "product range", "fan selection", "details", "system components", and "output". The "fan selection" tab is active. Below the navigation, there are input fields for search criteria: "air flow volume" (4000 m³/h), "static pressure / total pressure" (50 Pa), "mains supply" (3° / 400V / 50Hz), and "ambient temperature" (20 °C). There are also checkboxes for "design influence" and "search tolerance" (10%). A "selection criteria" section shows a fan icon and "axial fans" selected. The search results show 42 hits, with a table listing fan models, their types, and various performance parameters.

add to watch list	type [-]	article no. [-]	Q _v [m³/h]	P _{st} [Pa]	D _p [Pa]	SFP [W/(m³/h)]	P _{sys} [W]	P _{sys} [W]	η _{f,sys} [%]	η _f [%]	n [1/min]	w _{v(A),5} [dB]	w _{v(A),6} [dB]	f _{DP} [Hz]	V _{DP} [V]	I _{DP} [A]	Q _v [m³/h]	P _{st} [Pa]	mains supply [-]
	FN050-ZIA.DC.VP2	154383	4000	50	69	1	159	173	44.5	-	860	66	65	50	400	0.46	3°	400V	50Hz
	FN050-ZIA.DC.A.P2	154399	4000	50	69	1	159	173	44.3	-	860	66	65	50	400	0.46	3°	400V	50Hz
	FN056-ZIA.DC.VP1	152852	4000	50	63	1	147	160	43.5	-	725	63	63	50	400	0.48	3°	400V	50Hz
	FN056-ZIA.DC.A.P1	152828	4000	50	63	1	147	160	43.5	-	725	63	63	50	400	0.48	3°	400V	50Hz
	FN063-ZIA.DG.VP2	152764	4000	50	57	1	138	147	43.4	-	582	64	63	50	400	0.41	3°	400V	50Hz
	FN063-ZIA.DG.A.P2	152760	4000	50	57	1	138	147	43.4	-	582	64	63	50	400	0.41	3°	400V	50Hz
	FN056-ZIQ.DC.VP1	152870	4000	50	62	1	155	167	41.7	-	739	64	66	50	400	0.45	3°	400V	50Hz
	FN056-ZIQ.DC.A.P1	152846	4000	50	62	1	155	167	41.7	-	739	64	66	50	400	0.45	3°	400V	50Hz
	FN056-ZID.DC.VP1	152858	4000	50	62	1	155	167	41.7	-	739	64	66	50	400	0.45	3°	400V	50Hz
	FN056-ZIQ.DC.A.P1	152846	4000	50	62	1	155	167	41.7	-	739	64	66	50	400	0.45	3°	400V	50Hz
	FN056-ZID.DC.A.P1	152834	4000	50	62	1	155	167	41.7	-	739	64	66	50	400	0.45	3°	400V	50Hz
	FN050-ZIQ.DC.VP2	154401	4000	50	70	1	174	192	40.3	-	889	67	68	50	400	0.48	3°	400V	50Hz
	FN050-ZIS.DC.VP2	154389	4000	50	70	1	174	192	40.3	-	889	67	68	50	400	0.48	3°	400V	50Hz
	FN050-ZIQ.DC.A.P2	154377	4000	50	70	1	174	192	40.3	-	889	67	68	50	400	0.48	3°	400V	50Hz

At www.fanselect.info, we are offering you FANselect, a selection program for axial and centrifugal fans with the matching system components.

With FANselect, you can, for instance, select and calculate the fans listed in this catalogue. FANselect provides you with an option to calculate the efficiency, the acoustics, the SFP and much more. In addition, you can also select the matching systems components. You can conveniently save your configuration in a file or print it out.

The FANselect selection program, including the customer DLL, is available for you to download at any time at www.fanselect.info.

The screenshot shows the detailed view of a selected fan model (FN050-ZIA.DC.A.P2) in the FANselect application. The interface includes a table of key performance indicators (KPIs) and three graphs: "air performance", "efficiency", and "acoustics".

type [-]	P _{SFP} [W/(m³/h)]	P _{sys} [W]	η _{f,sys} [%]	η _f [%]	n [1/min]	w _{v(A),5} [dB]	w _{v(A),6} [dB]	f _{DP} [Hz]	V _{DP} [V]	I _{DP} [A]	Q _v [m³/h]	P _{st} [Pa]	
FN050-ZIA.DC.A.P2	159	173	32.0	44.3	860	78	66	77	65	50	400	0.46	170

The "air performance" graph shows static pressure (Pa) vs. air flow volume (m³/h) with a peak at 1550 l/min. The "efficiency" graph shows η_{f,sys} [%] vs. air flow volume (m³/h) with a peak at 30%. The "acoustics" graph shows L_{w(A),5} [dB] vs. air flow volume (m³/h) with a peak at 80 dB.

Applications

Low pressure

- Low pressure losses, e.g. stack installation, wall fan, air circulation in the stable
- Maximum ~ 100 Pa possible
- Application areas usually between 30-50 Pa

- ① Fan at stack inlet
- ② Fan in the stack
- ③ Air circulation
- ④ Cross ventilation
- ⑤ Longitudinal ventilation

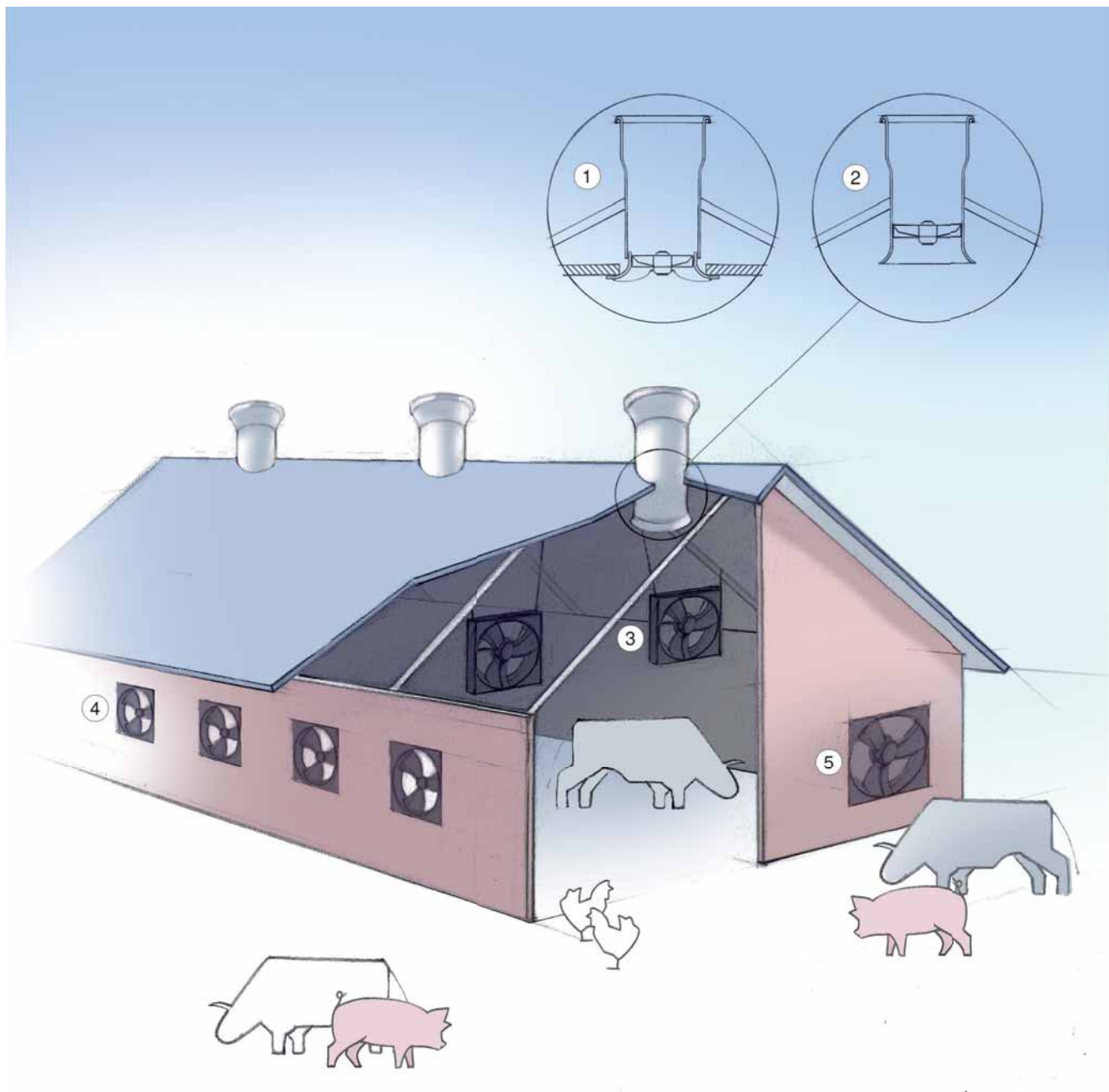

High pressure

- Higher pressure losses, e.g. in the case of pipe or duct system, heat exchanger, filter
- Maximum ~ 500 Pa possible
- Application areas usually between 150-200 Pa

- ① Central waste air flow
- ② Waste air purification

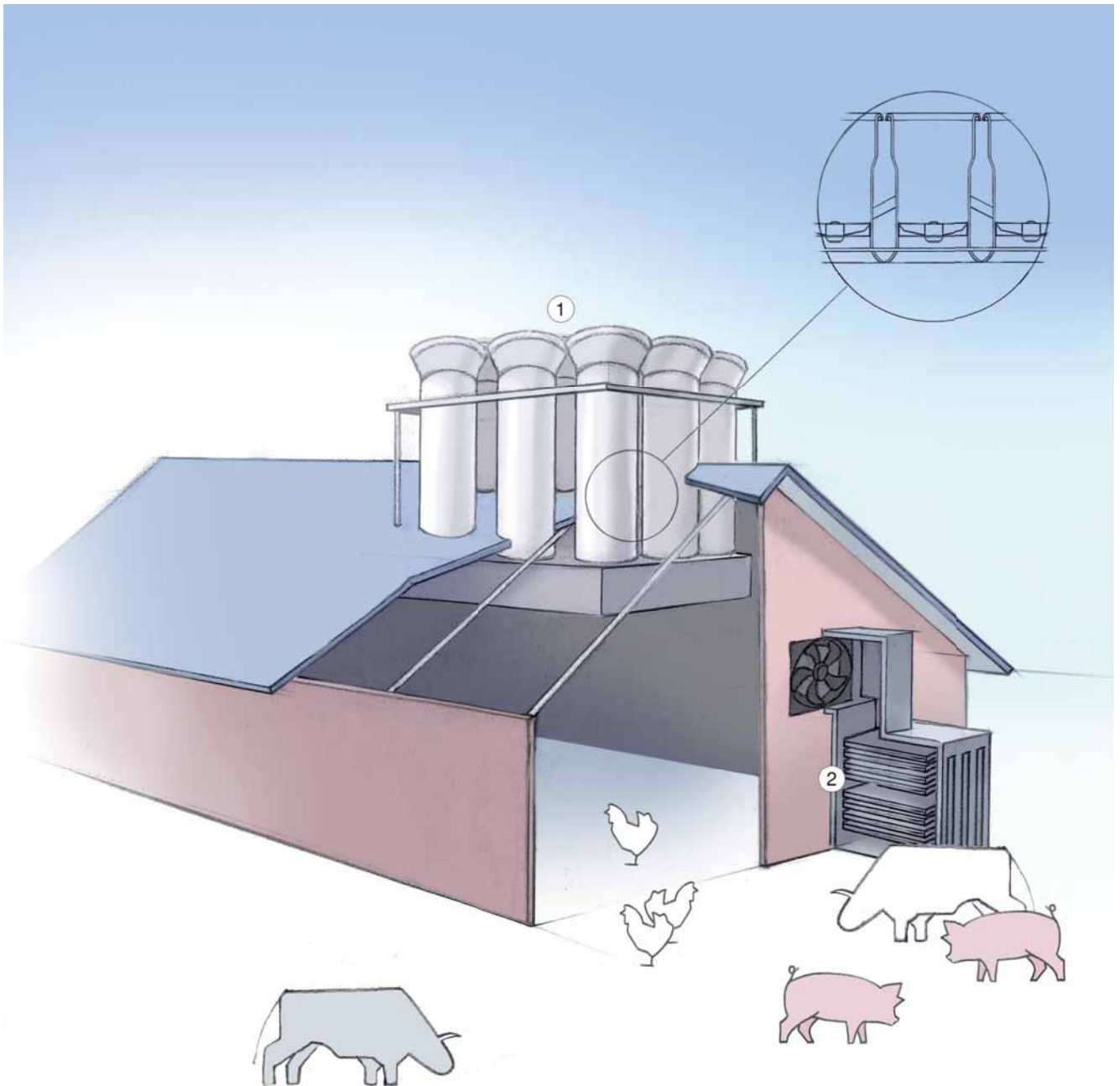

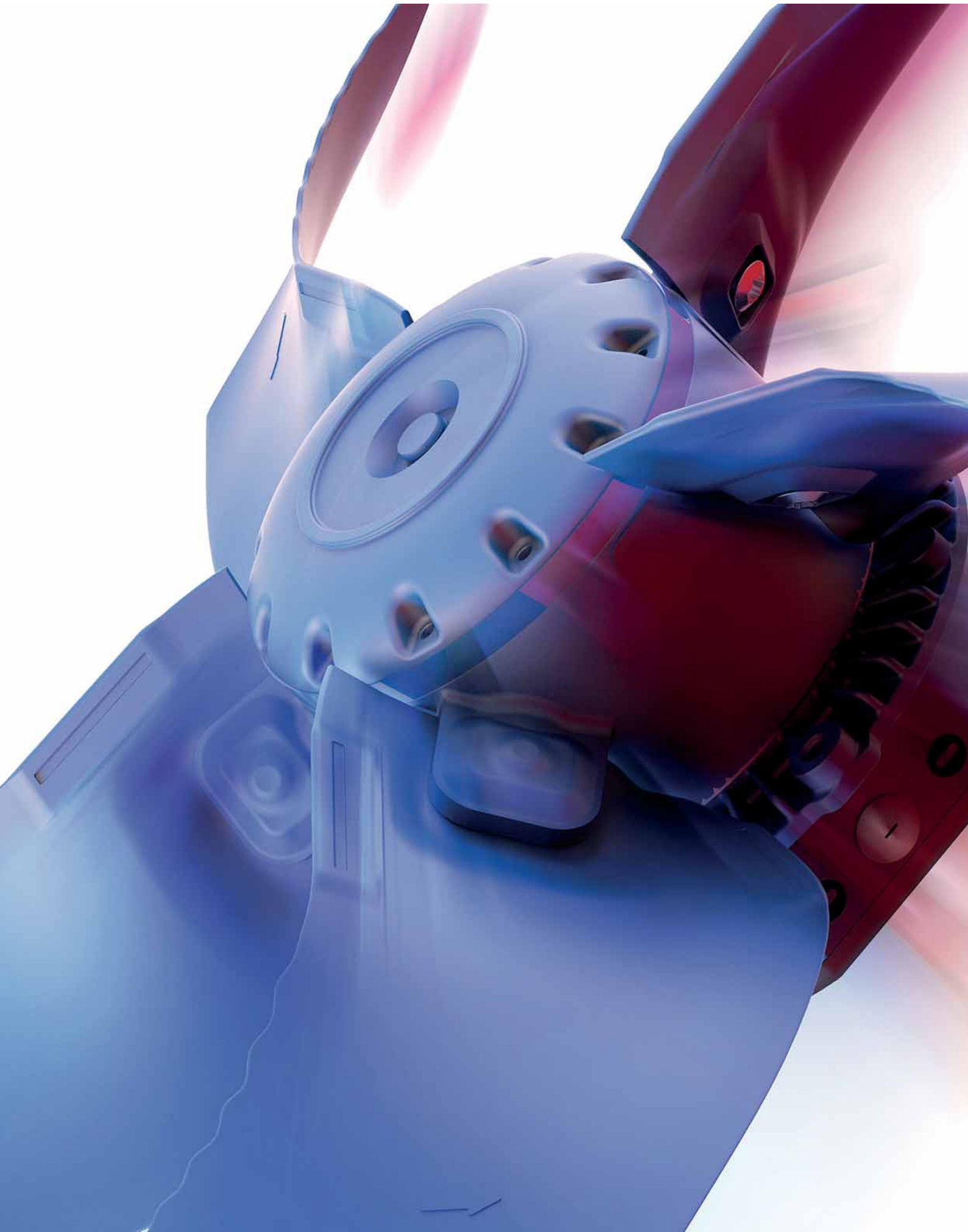

Low pressure fans

Product overview

Fans overview	Page 28
EC Technology	
Size 400	Page 30
Size 450	Page 32
Size 500	Page 34
Size 560	Page 36
Size 630	Page 38
Size 710	Page 42
Size 800	Page 44
Size 910	Page 46
Size 1250	Page 50
AC Technology	
Size 500	Page 52
Size 560	Page 54
Size 630	Page 58
Size 710	Page 64
Size 800	Page 66
Size 910	Page 70
Size 1250	Page 76
FC size 350 to 500	Page 78

Fans overview

EC technology

Product overview

Type	Rating plate information				Values at operating point			Acoustic pressure level 7m	
	P ₁ kW	U V	I A	n min-1	p=0 Pa	p=30 Pa			
					q _v m ³ /h	q _v m ³ /h	P _{spez} Wh/1000m ³	L _{pA} dB(A)	
FN040-ZI_DC.A7P5	0,82	1~ 200-277	4,2-3,4	1.950	6.707	6.479	114,2	55	Page 30
FN045-ZI_DC.A5P4	0,76	1~ 200-277	3,9-3,3	1.650	7.695	7.415	84,9	51	Page 32
FF050-ZI_DC.A5P1	0,94	1~ 200-277	4,8-3,5	1.800	11.241	10.767	80,0	55	Page 34
FF056-ZI_DC.A5P1	0,98	1~ 200-277	5,0-3,6	1.350	13.340	12.701	73,4	53	Page 36
FF063-ZI_DG.A5P1	0,92	1~ 200-277	4,6-3,3	1.200	15.353	14.539	59,2	50	Page 38
ZF063-ZI_DG.V5P1	0,94	1~ 200-277	4,8-3,4	1.200	15.588	14.916	57,2	56	Page 40
FF071-ZI_DG.A3P1	1,25	1~ 200-277	6,2-4,4	1.230	19.381	18.303	63,0	56	Page 42
FF080-ZI_DG.A3P1	1,15	1~ 200-277	5,8-4,2	1.090	22.476	20.842	51,3	52	Page 44
FF091-ZI_DG.A3P1	0,96	1~ 200-277	5-3,6	950	24.650	22.502	40,3	52	Page 46
ZF091-ZI_DG.V3P1	0,86	1~ 200-277	4,2-3,1	910	24.013	21.916	36,3	54	Page 48
FN125-ZI_GQ.A3P1	3,10	3~ 380-480	5-3,9	680	53.763	50.389	46,7	54	Page 50



AC technology

Product overview

Type	Rating plate information				Values at operating point				Acoustic pressure level 7m	
					p=0 Pa		p=30 Pa			
	P ₁ kW	U V	I A	n min-1	q _v m ³ /h	q _v m ³ /h	P _{spez} Wh/1000m ³	L _{pA} dB(A)		
ZC050-4E_4F.V7	0,46	1~ 230	2,1	1.220	7.838	7.289	56,0	51	Page 52	
FF056-6E_4I.A5R2	0,40	1~ 230	1,9	920	9.499	8.587	47,3	49	Page 54	
FF056-6D_4I.A5R2	0,39	3~ 230/400	1,5/0,86	930	9.512	8.602	45,1	49	Page 56	
FF063-6E_4I.A5R2	0,52	1~ 230	2,5	890	12.105	10.829	47,4	46	Page 58	
ZF063-6E_4I.V5R2	0,52	1~ 230	2,5	890	12.156	10.953	46,8	47	Page 60	
FF063-6D_4I.A5R2	0,54	3~ 230/400	2,2/1,25	930	12.297	11.163	45,8	46	Page 62	
FF071-6D_6F.A3P2	0,60	3~ 230/400	2,7/1,55	940	14.544	13.142	43,8	49	Page 64	
FF080-6E_6F.A3P2	0,76	1~ 230	3,4	880	18.540	16.253	44,7	50	Page 66	
FF080-6D_6F.A3P2	0,76	3~ 230/400	3,1/1,8	920	19.022	17.076	42,5	50	Page 68	
FF091-6E_6F.A3P2	0,94	1~ 230	4,2	840	22.761	19.588	46,4	49	Page 70	
FF091-6D_6F.A3P2	0,92	3~ 230/400	3,3/1,9	880	23.454	20.992	42,3	50	Page 72	
ZF091-6D_6F.V3P2	0,90	3~ 230/400	3,4/1,95	890	23.769	21.469	39,9	55	Page 74	
FN125-MD_7Q.A3P1	1,95/1,2	3~ 400	4,6/2,4	530/400	43.751	38.937	43,1	48	Page 76	



Information

Low pressure

High pressure

System components

Control technology

Appendix

FE2owlet-ECblue

for single phase alternating current, 200-277 V

FNO40



Description

Motor technology: EC
 Rated voltage U_N : 1~ 200-277 V*
 Rated frequency f_N : 50/60 Hz*
 Input power P_{sys} : 0.82 kW*
 Rated current I_N : 4.20-3.40 A*
 Rated speed n_N : 1950 min⁻¹*
 Thermal class: **THCL155***
 Min. permitted ambient temperature $t_{R(min)}$: -35 °C ***
 Max. permitted ambient temperature $t_{R(max)}$: 60 °C
 Electrical connection: Integrated controller with attached cable
 Number of blades: 7
 Degree of protection : IP55
 Motor protection: Integrated active temperature management
 Blades: High Performance Composite Material, uncoated, black
 Rotor: Aluminium, 1 coat paint, ultramarine blue
 Conformity: ErP 2015, CE, UL

ErP-data

Efficiency η_{statA} : 39.3 %
 Efficiency: $N_{actual} = 46.2 / N_{target} = 40$ **

EC controller integrated

* Rated data

**ErP 2015

*** Continuous operation with occasional starts (S1) according to DIN EN 60034-1:2011-02. Occasional starting between -35 °C and -25 °C is permissible. Continuous operation below -25 °C only with special bearings for refrigeration applications on request.

Characteristic curve

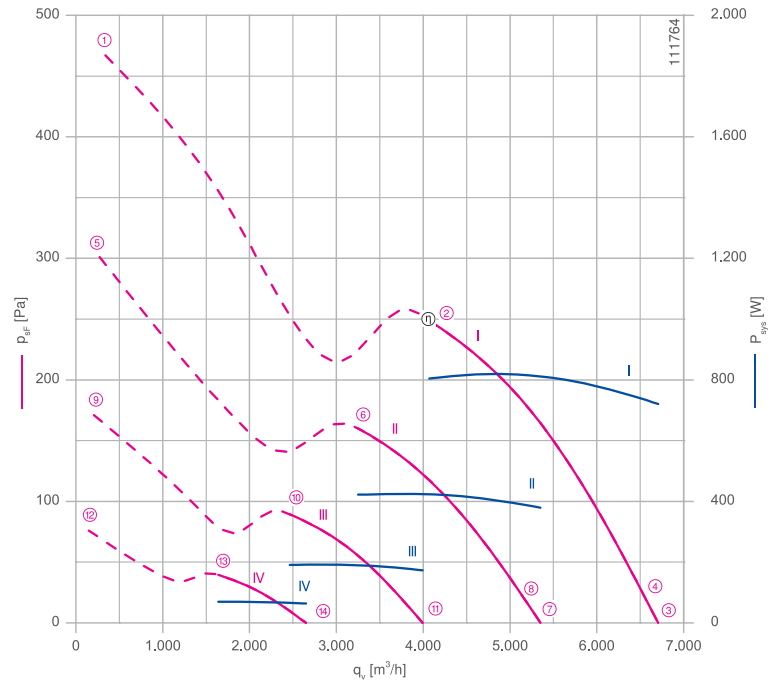

Measured in full bell mouth without guard grille in installation type A according to ISO 5801.

Connection diagram Page 173
 0-10 V 1360-389
 10-0 V

System components Page 110

Dimensions mm

Airflow direction A

Design T - for installation in chimney exhausts, without guard grille

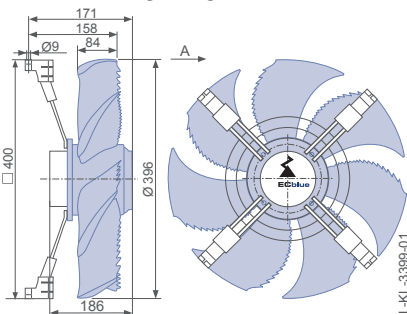

Design Q - square full bell mouth, without guard grille

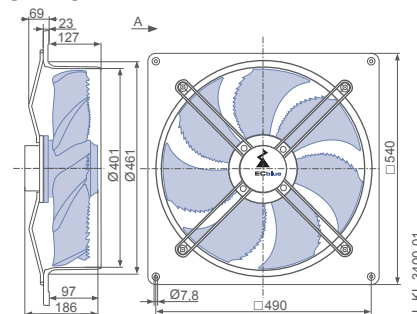

Design Q - square full bell mouth, guard grille suction side

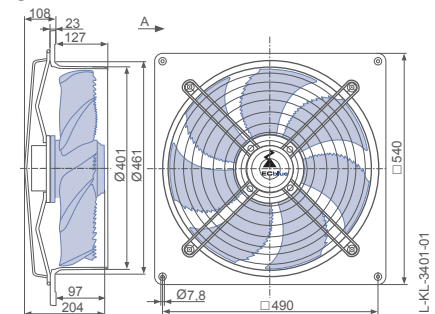

Wall ring plate made of composite material

Wall ring plate made of composite material





Performance data

Type	Characteristic curve	Speed n min ⁻¹	Operating point	Current	Input power	Acoustic pressure level 7m	Specific power
				I A	P _{sys} W	L _{pA} dB(A)	P _{spez} Wh/1000m ³
FN040-ZL_DC_7P5	I	1950	①	4.60	1050		
			②	3.60	800		197.7
			③	3.20	720	55	107.5
			④	3.30	740	55	114.2
	II	1560	⑤	2.50	540		
			⑥	1.95	420		129.3
			⑦	1.75	380	50	70.9
			⑧	1.80	390	49	77.7
	III	1170	⑨	1.15	240		
			⑩	0.92	190		77.9
			⑪	0.82	170	43	43.3
	IV	780	⑫	0.44	85		
			⑬	0.38	70		42.5
			⑭	0.36	65	33	24.1

Current values determined at 230V

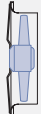

Fan ordering information

Airflow direction A →

Design	T (without guard grille)	Q (without guard grille)	Q (guard grille suction side)
			
Type	FN040-ZIT.DC.A7P5	FN040-ZIQ.DC.A7P5	FN040-ZIQ.DC.A7P5
0-10 V	Article no. 168977	168978	168979
10-0 V	Article no. 169688	169689	169690
Wall ring plate		Wall ring plate made of composite material	Wall ring plate made of composite material
Weight kg	9.40	12.70	14.20
Supply temperature -10°C - max 40°C in design with wall ring plate made of composite material			

Control technology

Control module UNIcon Zenec switch

	
Page 130	Page 158

Information

Low pressure

High pressure

System components

Control technology

Appendix

FE2owlet-ECblue

for single phase alternating current, 200-277 V

FNO45



Description

Motor technology: EC
 Rated voltage U_N : 1~ 200-277 V*
 Rated frequency f_N : 50/60 Hz*
 Input power P_{sys} : 0.76 kW*
 Rated current I_N : 3.90-3.30 A*
 Rated speed n_N : 1650 min⁻¹*
 Thermal class: THCL155*
 Min. permitted ambient temperature $t_{R(min)}$: -35 °C ***
 Max. permitted ambient temperature $t_{R(max)}$: 60 °C
 Electrical connection: Integrated controller with attached cable
 Number of blades: 5
 Degree of protection : IP55
 Motor protection: Integrated active temperature management
 Blades: High Performance Composite Material, uncoated, black

Rotor: Aluminium, 1 coat paint, ultramarine blue
 Conformity: ErP 2015, CE, UL

ErP-data

Efficiency η_{statA} : 41.2 %
 Efficiency: $N_{actual} = 48.3 / N_{target} = 40$ **

EC controller integrated

* Rated data

**ErP 2015

*** Continuous operation with occasional starts (S1) according to DIN EN 60034-1:2011-02. Occasional starting between -35 °C and -25 °C is permissible. Continuous operation below -25 °C only with special bearings for refrigeration applications on request.

Characteristic curve

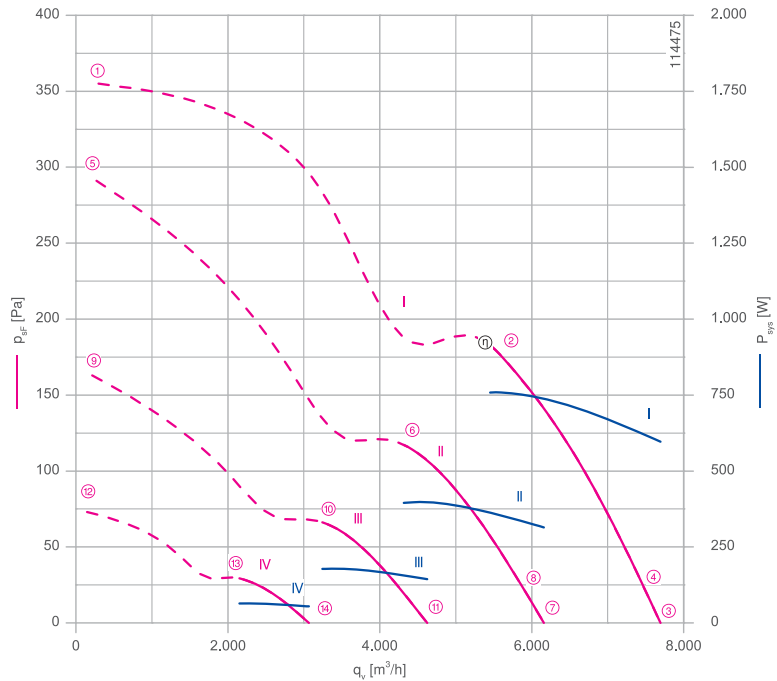

Measured in full bell mouth without guard grille in installation type A according to ISO 5801.

Connection diagram Page 173
 0-10 V 1360-389
 10-0 V

System components Page 110

Dimensions mm

Airflow direction A

Design T - for installation in chimney exhausts, without guard grille

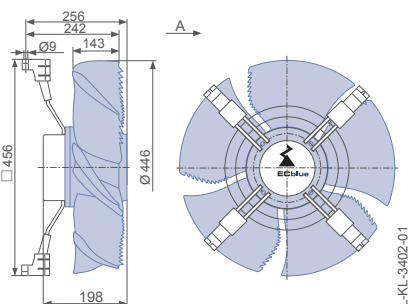

Design Q - square full bell mouth, without guard grille

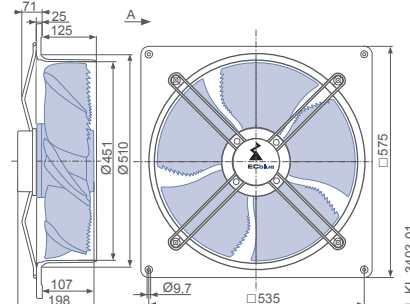

Wall ring plate made of composite material

Design Q - square full bell mouth, guard grille suction side

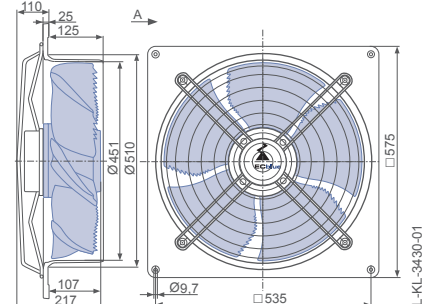

Wall ring plate made of composite material





Performance data

Type	Characteristic curve	Speed n min ⁻¹	Operating point	Current	Input power	Acoustic pressure level 7m	Specific power
				I A	P _{sys} W	L _{pA} dB(A)	P _{spez} Wh/1000m ³
FN045-ZL_DC_5P4	I	1650	①	3.50	780		
			②	3.40	760		140.2
			③	2.70	600	51	77.5
			④	2.90	620	51	84.9
	II	1320	⑤	2.60	580		
			⑥	1.85	390		91.7
			⑦	1.50	310	45	51.1
			⑧	1.60	340	45	58.5
	III	990	⑨	1.20	250		
			⑩	0.84	180		54.9
			⑪	0.68	140	38	31.2
			⑫	0.44	85		
	IV	660	⑬	0.37	65		
			⑭	0.33	55	28	17.7

Current values determined at 230V

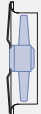

Fan ordering information

Airflow direction A

Design	T (without guard grille)	Q (without guard grille)	Q (guard grille suction side)
			
Type	FN045-ZIT.DC.A5P4	FN045-ZIQ.DC.A5P4	FN045-ZIQ.DC.A5P4
0-10 V	Article no. 168981	168982	168983
10-0 V	Article no. 169692	169693	169694
Wall ring plate		Wall ring plate made of composite material	Wall ring plate made of composite material
Weight kg	9.90	13.40	14.90
Supply temperature -10°C - max 40°C in design with wall ring plate made of composite material			

Control technology

Control module UNIcon Zenec switch

	
Page 130	Page 158

FFowlet-ECblue

for single phase alternating current, 200-277 V

FF050



Description

Motor technology: EC
 Rated voltage U_N : 1~ 200-277 V*
 Rated frequency f_N : 50/60 Hz*
 Input power P_{sys} : 0.94 kW*
 Rated current I_N : 4.80- 3.50 A*
 Rated speed n_N : 1800 min⁻¹*
 Thermal class: **THCL155***
 Min. permitted ambient temperature $t_{R(min)}$: -35 °C ***
 Max. permitted ambient temperature $t_{R(max)}$: 60 °C
 Electrical connection: Integrated controller with attached cable
 Number of blades: 5
 Degree of protection : IP55
 Motor protection: Integrated active temperature management
 Blades: Aluminium, powder-coated, ultramarine blue
 Rotor: Aluminium, 1 coat paint, ultramarine blue
 Conformity: ErP 2015, CE, UL

ErP-data

Efficiency η_{statA} : 41.7 %
 Efficiency: $N_{actual} = 48.3 / N_{target} = 40$ **
 EC controller integrated

* Rated data

**ErP 2015

*** Continuous operation with occasional starts (S1) according to DIN EN 60034-1:2011-02. Occasional starting between -35 °C and -25 °C is permissible. Continuous operation below -25 °C only with special bearings for refrigeration applications on request.

Characteristic curve

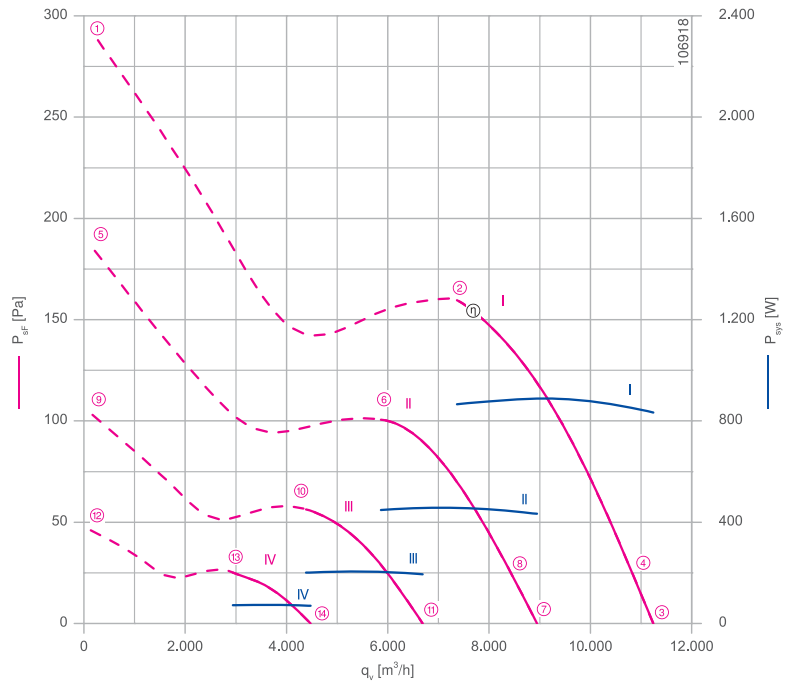

Measured in full bell mouth without guard grille in installation type A according to ISO 5801.

Connection diagram Page 173
 0-10 V 1360-389
 10-0 V

System components Page 110

Dimensions mm

Airflow direction A

Design T - for installation in chimney exhausts, without guard grille

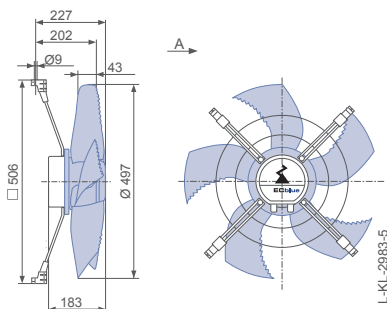

Design Q - square full bell mouth, without guard grille

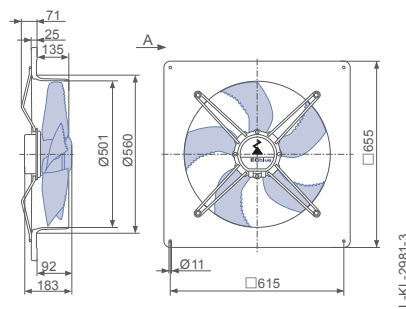

Wall ring plate made of composite material

Design Q - square full bell mouth, guard grille suction side

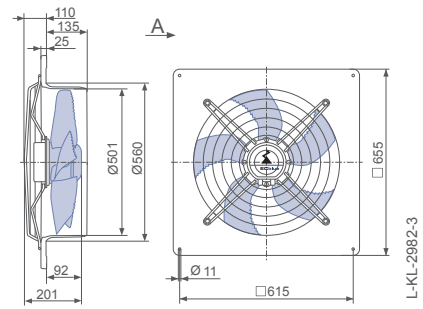

Wall ring plate made of composite material



Performance data

Type	Characteristic curve	Speed n min ⁻¹	Operating point	Current	Input power	Acoustic pressure level 7m	Specific power
				I A	P _{sys} W	L _{pA} dB(A)	P _{spez} Wh/1000m ³
FF050-ZI_DC_5P1	I	1800	①	4.80	1050		
			②	3.90	860		118.2
			③	3.70	840	55	74.2
			④	3.80	860	55	80.0
	II	1440	⑤	2.50	560		
			⑥	2.10	440		76.9
			⑦	2.00	440	49	48.4
			⑧	2.10	460	49	54.0
	III	1080	⑨	1.15	240		
			⑩	0.96	200		46.0
			⑪	0.94	190	44	29.0
			⑫	0.44	85		
	IV	720	⑬	0.40	70		
			⑭	0.40	70	36	24.7
							15.7

Current values determined at 230V

Fan ordering information

Airflow direction A					
Design	T (without guard grille)	Q (without guard grille)	Q (guard grille suction side)	Q (without guard grille)	Q (guard grille suction side)
Type	FF050-ZIT.DC.A5P1	FF050-ZIQ.DC.A5P1	FF050-ZIQ.DC.A5P1	FF050-ZIQ.DC.A5P1	FF050-ZIQ.DC.A5P1
0-10 V					
Article no.	165232	165230	165231	167548	167550
10-0 V					
Article no.	165237	165235	165236	167549	167551
Wall ring plate		Wall ring plate made of composite material	Wall ring plate made of composite material	Wall ring plate made of galvanized sheet steel	Wall ring plate made of galvanized sheet steel
Weight kg	12.00	15.80	17.50	19.10	20.80
Supply temperature	-10°C - max 40°C in design with wall ring plate made of composite material				

Control technology

Control module UNIcon Zenec switch



Page 130



Page 158

Design Q - square full bell mouth, without guard grille

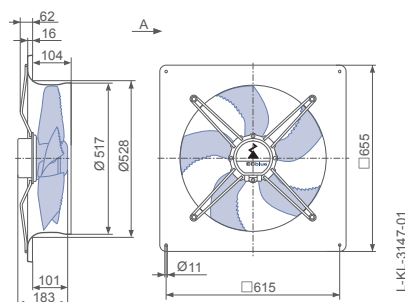

Wall ring plate made of galvanized sheet steel

Design Q - square full bell mouth, guard grille suction side

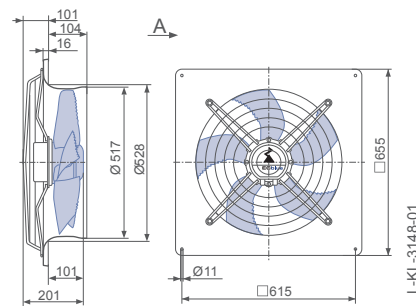

Wall ring plate made of galvanized sheet steel

FFowlet-ECblue

for single phase alternating current, 200-277 V

FF056



Description

Motor technology: EC
 Rated voltage U_N : 1~ 200-277 V*
 Rated frequency f_N : 50/60 Hz*
 Input power P_{sys} : 0.98 kW*
 Rated current I_N : 5.00- 3.60 A*
 Rated speed n_N : 1350 min⁻¹*
 Thermal class: THCL155*
 Min. permitted ambient temperature $t_{R(min)}$: -35 °C ***
 Max. permitted ambient temperature $t_{R(max)}$: 50 °C
 Electrical connection: Integrated controller with attached cable
 Number of blades: 5
 Degree of protection : IP55
 Motor protection: Integrated active temperature management
 Blades: Aluminium, powder-coated, ultramarine blue
 Rotor: Aluminium, 1 coat paint, ultramarine blue
 Conformity: ErP 2015, CE, UL

ErP-data

Efficiency η_{statA} : 41.6 %
 Efficiency: $N_{actual} = 48.0 / N_{target} = 40^{**}$
 EC controller integrated

* Rated data

**ErP 2015

*** Continuous operation with occasional starts (S1) according to DIN EN 60034-1:2011-02. Occasional starting between -35 °C and -25 °C is permissible. Continuous operation below -25 °C only with special bearings for refrigeration applications on request.

Characteristic curve

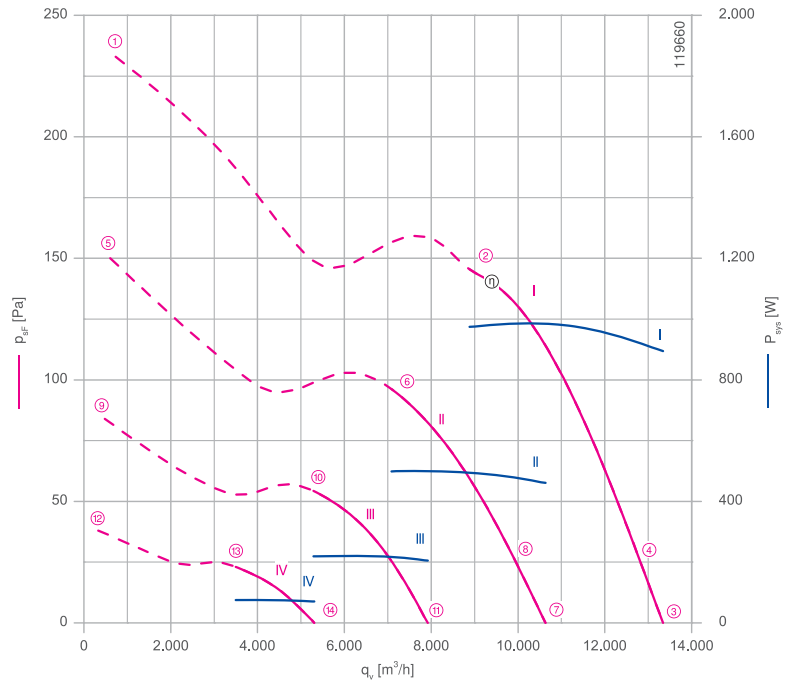

Measured in full bell mouth without guard grille in installation type A according to ISO 5801

Connection diagram Page 173
 0-10 V 1360-389
 10-0 V

System components Page 110

Dimensions mm

Airflow direction A

Design T - for installation in chimney exhausts, without guard grille

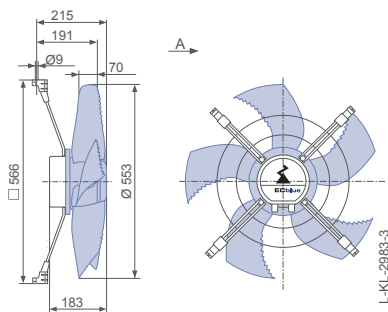

Design Q - square full bell mouth, without guard grille

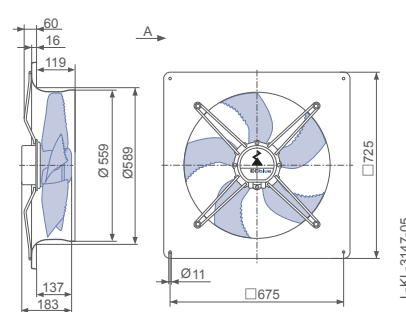

Wall ring plate made of galvanized sheet steel

Design Q - square full bell mouth, guard grille suction side

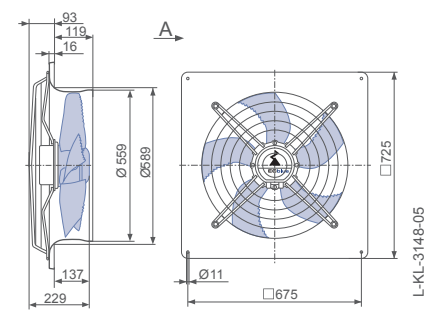

Wall ring plate made of galvanized sheet steel





Performance data



Type	Characteristic curve	Speed n min ⁻¹	Operating point	Current	Input power	Acoustic pressure level 7m	Specific power
				I A	P _{sys} W	L _{pA} dB(A)	P _{spez} Wh/1000m ³
FF056-ZI_DC_5P1	I	1350	①	5.00	1150		
			②	4.20	980		111.0
			③	3.90	900	52	67.0
			④	4.00	940	53	73.4
	II	1080	⑤	2.60	580		
			⑥	2.20	500		70.4
			⑦	2.10	460	48	43.3
			⑧	2.20	480	48	49.3
	III	810	⑨	1.15	250		
			⑩	1.00	220		41.2
			⑪	0.96	200	42	25.8
	IV	540	⑫	0.44	85		
			⑬	0.42	75		21.6
			⑭	0.40	70	34	13.3

Current values determined at 230V

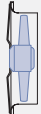
Fan ordering information

Airflow direction A			
Design	T (without guard grille)	Q (without guard grille)	Q (guard grille suction side)
			
Type	FF056-ZIT.DC.A5P1	FF056-ZIQ.DC.A5P1	FF056-ZIQ.DC.A5P1
0-10 V	Article no. 171918	171916	171917
10-0 V	Article no. 171922	171920	171921
Wall ring plate		Wall ring plate made of galvanized sheet steel	Wall ring plate made of galvanized sheet steel
Weight kg	12.80	21.90	23.90

Control technology

Control module UNIcon Zenec switch	
	
Page 130	Page 158

FFowlet-ECblue

for single phase alternating current, 200-277 V

FF063



Description

Motor technology: EC
 Rated voltage U_N : 1~ 200-277 V*
 Rated frequency f_N : 50/60 Hz*
 Input power P_{sys} : 0.92 kW*
 Rated current I_N : 4.60- 3.30 A*
 Rated speed n_N : 1200 min⁻¹*
 Thermal class: **THCL155***
 Min. permitted ambient temperature $t_{R(min)}$: -35 °C ***
 Max. permitted ambient temperature $t_{R(max)}$: 55 °C
 Electrical connection: Integrated controller with attached cable
 Number of blades: 5
 Degree of protection : IP55
 Motor protection: Integrated active temperature management
 Blades: Aluminium, powder-coated, ultramarine blue
 Rotor: Aluminium, 1 coat paint, ultramarine blue
 Conformity: ErP 2015, CE, UL

ErP-data

Efficiency η_{statA} : 46.1 %
 Efficiency: $N_{actual} = 52.7 / N_{target} = 40^{**}$
 EC controller integrated

* Rated data

**ErP 2015

*** Continuous operation with occasional starts (S1) according to DIN EN 60034-1:2011-02. Occasional starting between -35 °C and -25 °C is permissible. Continuous operation below -25 °C only with special bearings for refrigeration applications on request.

Characteristic curve

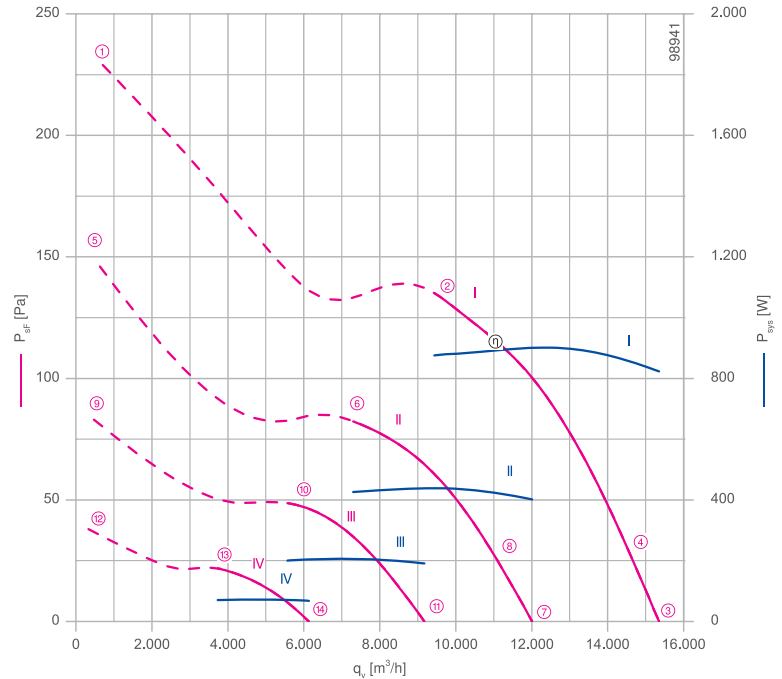

Measured in full bell mouth without guard grille in installation type A according to ISO 5801.

Connection diagram Page 173
 0-10 V 1360-389
 10-0 V

System components Page 110

Dimensions mm

Airflow direction A

Design T - for installation in chimney exhausts, without guard grille

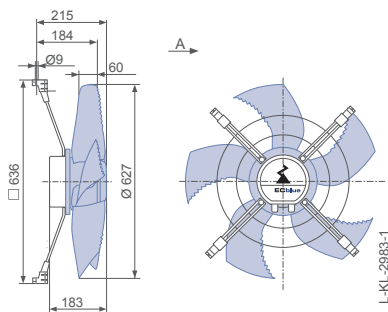

Design Q - square full bell mouth, without guard grille

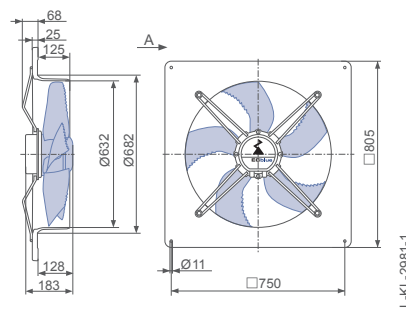

Wall ring plate made of composite material

Design Q - square full bell mouth, guard grille suction side

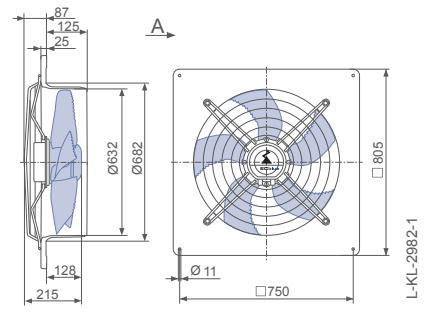

Wall ring plate made of composite material



Performance data

Type	Characteristic curve	Speed n min ⁻¹	Operating point	Current	Input power	Acoustic pressure level 7m	Specific power
				I A	P _{sys} W	L _{pA} dB(A)	P _{spez} Wh/1000m ³
FF063-ZI_DG_5P1	I	1200	①	4.60	1050		
			②	3.90	880		93.7
			③	3.70	820	51	53.6
			④	3.80	860	50	59.2
	II	940	⑤	2.40	540		
			⑥	1.95	420		58.5
			⑦	1.85	400	45	33.5
			⑧	2.00	420	45	39.2
	III	720	⑨	1.15	240		
			⑩	0.96	200		36.0
			⑪	0.90	190	40	20.8
			⑫	0.44	85		
	IV	480	⑬	0.40	70		18.9
			⑭	0.40	70	31	11.1

Current values determined at 230V

Fan ordering information

Airflow direction A					
Design	T (without guard grille)	Q (without guard grille)	Q (guard grille suction side)	Q (without guard grille)	Q (guard grille suction side)
Type	FF063-ZIT.DG.A5P1	FF063-ZIQ.DG.A5P1	FF063-ZIQ.DG.A5P1	FF063-ZIQ.DG.A5P1	FF063-ZIQ.DG.A5P1
0-10 V					
Article no.	159948	159946	159947	166936	166938
10-0 V					
Article no.	159953	159951	159952	166937	166939
Wall ring plate		Wall ring plate made of composite material	Wall ring plate made of composite material	Wall ring plate made of galvanized sheet steel	Wall ring plate made of galvanized sheet steel
Weight kg	13.00	19.10	21.30	24.00	26.20
Supply temperature	-10°C - max 40°C in design with wall ring plate made of composite material				

Control technology

Control module UNIcon Zenec switch



Page 130



Page 158

Design Q - square full bell mouth, without guard grille

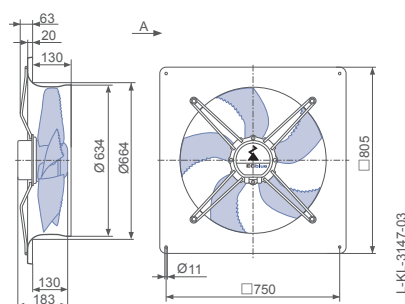

Wall ring plate made of galvanized sheet steel

Design Q - square full bell mouth, guard grille suction side

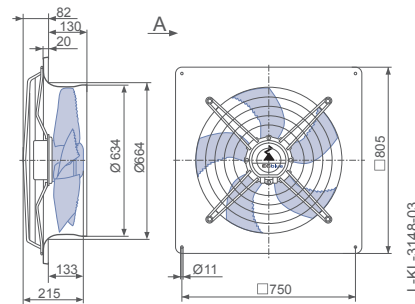

Wall ring plate made of galvanized sheet steel

FFowlet-ECblue with ZAplus

for single phase alternating current, 200-277 V

ZF063



Description

Motor technology: EC
 Rated voltage U_N : 1~ 200-277 V*
 Rated frequency f_N : 50/60 Hz*
 Input power P_{sys} : 0.94 kW*
 Rated current I_N : 4.80- 3.40 A*
 Rated speed n_N : 1200 min⁻¹*
 Thermal class: THCL155*
 Min. permitted ambient temperature $t_{R(min)}$: -35 °C ***
 Max. permitted ambient temperature $t_{R(max)}$: 50 °C
 Electrical connection: Terminal box
 Number of blades: 5
 Degree of protection : IP55
 Motor protection: Integrated active temperature management
 Blades: Aluminium, powder-coated, ultramarine blue
 Rotor: Aluminium, 1 coat paint, ultramarine blue
 Conformity: ErP 2015, CE, UL

ErP-data

Efficiency η_{statA} : 53.4 %
 Efficiency: $N_{actual} = 60.0 / N_{target} = 40^{**}$
 EC controller integrated

* Rated data

**ErP 2015

*** Continuous operation with occasional starts (S1) according to DIN EN 60034-1:2011-02. Occasional starting between -35 °C and -25 °C is permissible. Continuous operation below -25 °C only with special bearings for refrigeration applications on request.

Characteristic curve

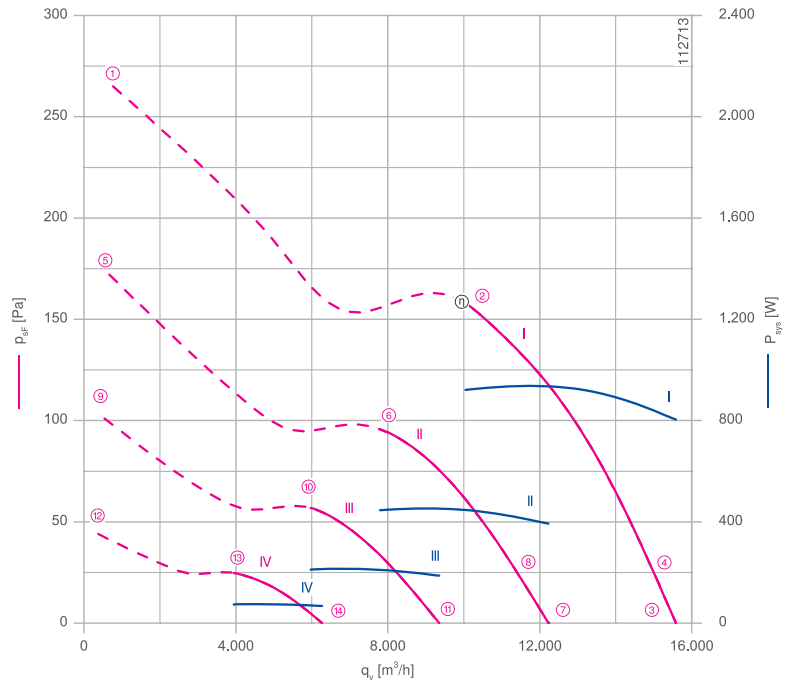

Measured in ZAplus without guard grille in installation type A according to ISO 5801.

Connection diagram Page 173
 0-10 V 1360-389
 Airflow direction V

System components Page 110

Dimensions mm

Airflow direction V

Design L - ZAplus Ontop without guard grille

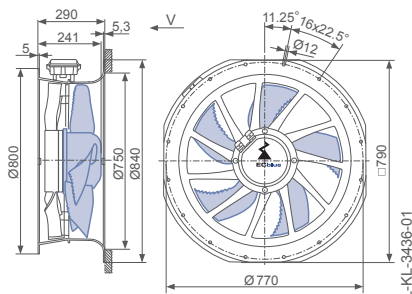

Performance data

Type	Characteristic curve	Speed n min ⁻¹	Operating point	Current	Input power	Acoustic pressure level 7m	Specific power
				I A	P _{sys} W	L _{pA} dB(A)	P _{spez} Wh/1000m ³
ZF063-ZI_DG_5P1	I	1200	①	5.00	1150		
			②	4.00	920		92.4
			③	3.50	800	56	51.6
			④	3.70	860	56	57.2
	II	940	⑤	2.70	600		
			⑥	2.00	440		57.6
			⑦	1.80	390	49	32.1
			⑧	1.95	420	49	38.0
	III	720	⑨	1.25	280		
			⑩	1.00	210		35.4
			⑪	0.92	190	42	20.0
	IV	480	⑫	0.47	90		
			⑬	0.40	75		18.8
			⑭	0.38	70	32	10.8

Current values determined at 230V

Fan ordering information

Airflow direction V

Design L (without guard grille)
Ontop



Type ZF063-ZIL.DG.V5P1
Article no. 169751

Weight kg 20.10

Control technology

Control module UNIcon Zenec switch



Page 130



Page 158

FFowlet-ECblue

for single phase alternating current, 200-277 V

FF071



Description

Motor technology: EC
 Rated voltage U_N : 1~ 200-277 V*
 Rated frequency f_N : 50/60 Hz*
 Input power P_{sys} : 1.25 kW*
 Rated current I_N : 6.20- 4.40 A*
 Rated speed n_N : 1230 min⁻¹*
 Thermal class: THCL155*
 Min. permitted ambient temperature $t_{R(min)}$: -35 °C ***
 Max. permitted ambient temperature $t_{R(max)}$: 50 °C
 Electrical connection: Integrated controller with attached cable
 Number of blades: 3
 Degree of protection : IP55
 Motor protection: Integrated active temperature management
 Blades: Aluminium, powder-coated, ultramarine blue
 Rotor: Aluminium, 1 coat paint, ultramarine blue
 Conformity: ErP 2015, CE, UL

ErP-data

Efficiency η_{statA} : 44.8 %
 Efficiency: $N_{actual} = 50.6 / N_{target} = 40^{**}$
 EC controller integrated

* Rated data

**ErP 2015

*** Continuous operation with occasional starts (S1) according to DIN EN 60034-1:2011-02. Occasional starting between -35 °C and -25 °C is permissible. Continuous operation below -25 °C only with special bearings for refrigeration applications on request.

Characteristic curve

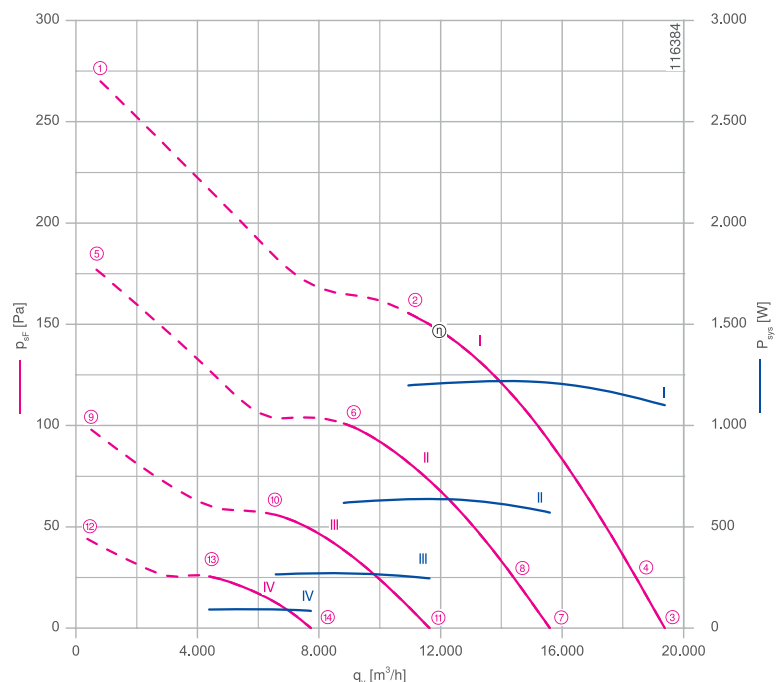

Measured in full bell mouth without guard grille in installation type A according to ISO 5801.

Connection diagram Page 173
 0-10 V 1360-389
 10-0 V

System components Page 110

Dimensions mm

Airflow direction A

Design T - for installation in chimney exhausts, without guard grille

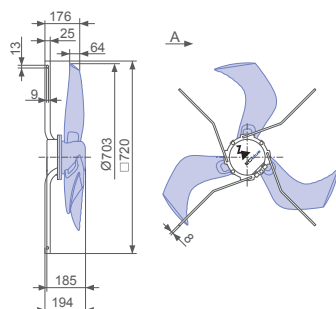

L-KL-3037-05

Design Q - square full bell mouth, without guard grille

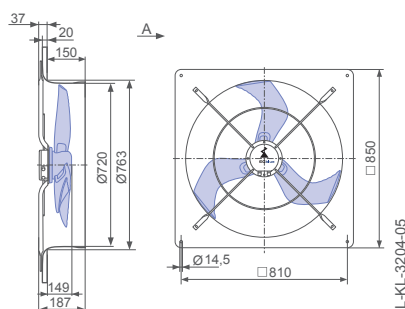

L-KL-3204-05

Wall ring plate made of galvanized sheet steel

Design Q - square full bell mouth, guard grille suction side

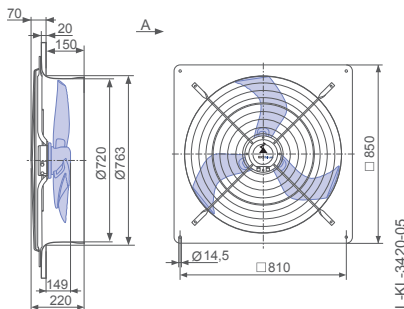

L-KL-3420-05

Wall ring plate made of galvanized sheet steel





Performance data



Type	Characteristic curve	Speed n min ⁻¹	Operating point	Current	Input power	Acoustic pressure level 7m	Specific power
				I A	P _{sys} W	L _{pA} dB(A)	P _{spez} Wh/1000m ³
FF071-ZI_DG_3P1	I	1220	①	6.40	1450		
			②	5.20	1200		110.1
			③	4.80	1100	55	56.8
			④	5.00	1150	56	63.0
	II	980	⑤	3.30	740		
			⑥	2.80	620		70.4
			⑦	2.50	580	51	36.6
			⑧	2.70	620	52	43.3
	III	730	⑨	1.45	320		
			⑩	1.20	270		40.7
			⑪	1.15	250	45	21.1
	IV	490	⑫	0.52	110		
			⑬	0.46	90		20.8
			⑭	0.44	85	38	11.0

Current values determined at 230V

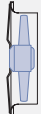
Fan ordering information

Airflow direction A			
Design	T (without guard grille)	Q (without guard grille)	Q (guard grille suction side)
			
Type	FF071-ZIT.DG.A3P1	FF071-ZIQ.DG.A3P1	FF071-ZIQ.DG.A3P1
0-10 V	Article no. 170306	170304	170305
10-0 V	Article no. 170311	170309	170310
Wall ring plate		Wall ring plate made of galvanized sheet steel	Wall ring plate made of galvanized sheet steel
Weight kg	14.50	25.60	29.00

Control technology

Control module UNIcon Zenec switch	
	
Page 130	Page 158

FFowlet-ECblue

for single phase alternating current, 200-277 V

FF080



Description

Motor technology: EC
 Rated voltage U_N : 1~ 200-277 V*
 Rated frequency f_N : 50/60 Hz*
 Input power P_{sys} : 1.15 kW*
 Rated current I_N : 5.80- 4.20 A*
 Rated speed n_N : 1090 min⁻¹*
 Thermal class: **THCL155***
 Min. permitted ambient temperature $t_{R(min)}$: -35 °C ***
 Max. permitted ambient temperature $t_{R(max)}$: 40 °C
 Electrical connection: Integrated controller with attached cable
 Number of blades: 3
 Degree of protection : IP55
 Motor protection: Integrated active temperature management
 Blades: Aluminium, powder-coated, ultramarine blue
 Rotor: Aluminium, 1 coat paint, ultramarine blue
 Conformity: ErP 2015, CE, UL

ErP-data

Efficiency η_{statA} : 48.8 %
 Efficiency: $N_{actual} = 54.8 / N_{target} = 40^{**}$
 EC controller integrated

* Rated data

**ErP 2015

*** Continuous operation with occasional starts (S1) according to DIN EN 60034-1:2011-02. Occasional starting between -35 °C and -25 °C is permissible. Continuous operation below -25 °C only with special bearings for refrigeration applications on request.

Characteristic curve

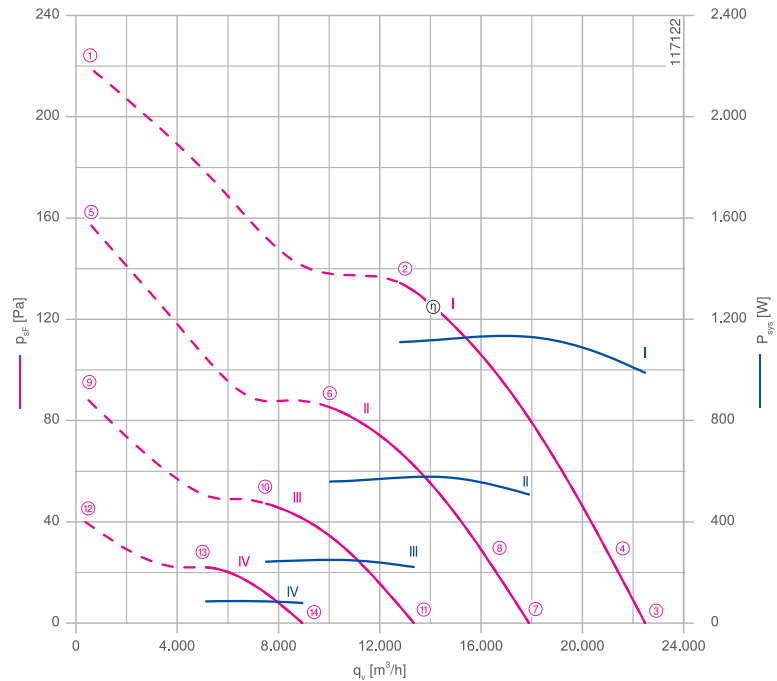

Measured in full bell mouth without guard grille in installation type A according to ISO 5801.

Connection diagram Page 173
 0-10 V 1360-389
 10-0 V

System components Page 110

Dimensions mm

Airflow direction A

Design T - for installation in chimney exhausts, without guard grille

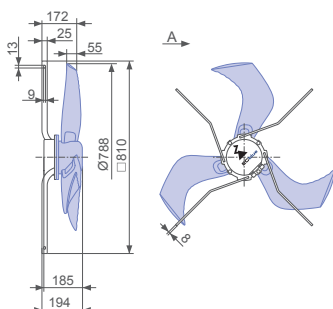

L-KL-3037-03

Design Q - square full bell mouth, without guard grille

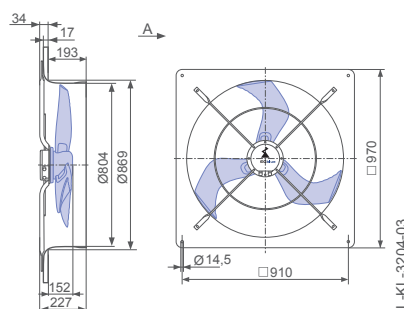

L-KL-3204-03

Wall ring plate made of galvanized sheet steel

Design Q - square full bell mouth, guard grille suction side

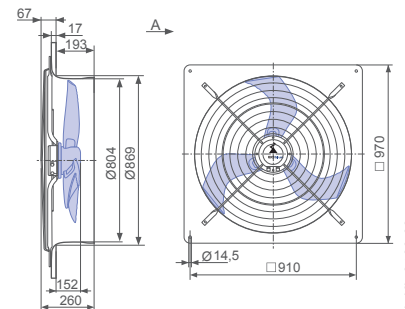

L-KL-3420-03

Wall ring plate made of galvanized sheet steel





Performance data



Type	Characteristic curve	Speed n min ⁻¹	Operating point	Current	Input power	Acoustic pressure level 7m	Specific power
				I A	P _{sys} W	L _{pA} dB(A)	P _{spez} Wh/1000m ³
FF080-ZI_DG_3P1	I	1090	①	5.20	1200		
			②	4.80	1100		87.6
			③	4.40	980	52	44.0
			④	4.60	1050	52	51.3
	II	870	⑤	3.20	720		
			⑥	2.50	560		55.7
			⑦	2.30	500	47	28.4
			⑧	2.50	560	50	35.1
	III	650	⑨	1.40	310		
			⑩	1.10	240		32.4
			⑪	1.00	220	42	16.6
	IV	440	⑫	0.52	110		
			⑬	0.44	85		16.8
			⑭	0.42	80	35	8.9

Current values determined at 230V

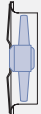
Fan ordering information

Airflow direction A			
Design	T (without guard grille)	Q (without guard grille)	Q (guard grille suction side)
			
Type	FF080-ZIT.DG.A3P1	FF080-ZIQ.DG.A3P1	FF080-ZIQ.DG.A3P1
0-10 V	Article no. 170255	170253	170254
10-0 V	Article no. 170260	170258	170259
Wall ring plate		Wall ring plate made of galvanized sheet steel	Wall ring plate made of galvanized sheet steel
Weight kg	14.50	30.10	33.90

Control technology

Control module UNIcon Zenec switch	
	
Page 130	Page 158

FFowlet-ECblue

for single phase alternating current, 200-277 V

FF091



Description

Motor technology: EC
 Rated voltage U_N : 1~ 200-277 V*
 Rated frequency f_N : 50/60 Hz*
 Input power P_{sys} : 0.96 kW*
 Rated current I_N : 5.00- 3.60 A*
 Rated speed n_N : 950 min⁻¹*
 Thermal class: THCL155*
 Min. permitted ambient temperature $t_{R(min)}$: -35 °C ***
 Max. permitted ambient temperature $t_{R(max)}$: 40 °C
 Electrical connection: Integrated controller with attached cable
 Number of blades: 3
 Degree of protection : IP55
 Motor protection: Integrated active temperature management
 Blades: Aluminium, powder-coated, ultramarine blue
 Rotor: Aluminium, 1 coat paint, ultramarine blue
 Conformity: ErP 2015, CE, UL

ErP-data

Efficiency η_{statA} : 51.3 %
 Efficiency: $N_{actual} = 57.8 / N_{target} = 40^{**}$
 EC controller integrated

* Rated data

**ErP 2015

*** Continuous operation with occasional starts (S1) according to DIN EN 60034-1:2011-02. Occasional starting between -35 °C and -25 °C is permissible. Continuous operation below -25 °C only with special bearings for refrigeration applications on request.

Characteristic curve

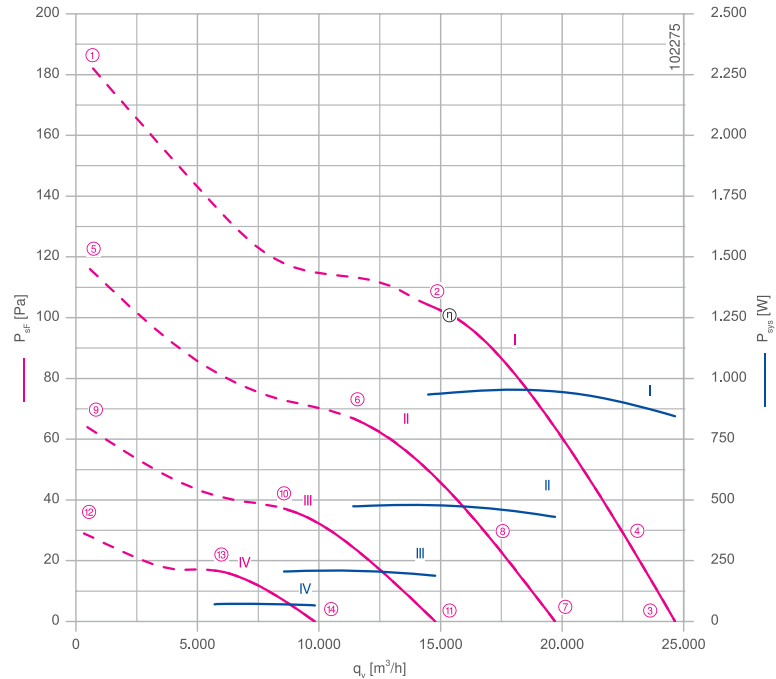

Measured in full bell mouth without guard grille in installation type A according to ISO 5801.

Connection diagram Page 173
 0-10 V 1360-389
 10-0 V

System components Page 110

Dimensions mm

Airflow direction A

Design T - for installation in chimney exhausts, without guard grille

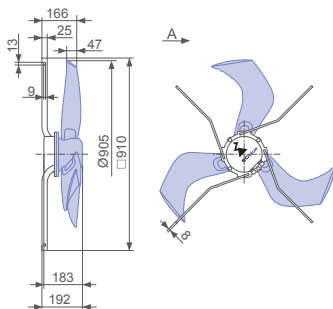

L-KL-3037-01

Design Q - square full bell mouth, without guard grille

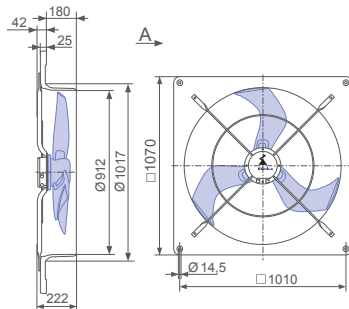

L-KL-3036-01

Wall ring plate made of composite material

Design Q - square full bell mouth, guard grille suction side

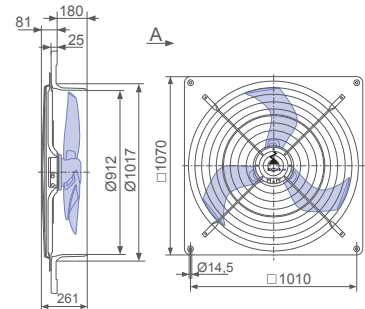

L-KL-3044-01

Wall ring plate made of composite material



Performance data

Type	Characteristic curve	Speed n min ⁻¹	Operating point	Current	Input power	Acoustic pressure level 7m	Specific power
				I A	P _{sys} W	L _{pA} dB(A)	P _{spez} Wh/1000m ³
FF091-ZI_DG_3P1	I	950	①	5.00	1100		
			②	4.20	940		65.4
			③	3.90	840	53	34.2
			④	4.20	900	52	40.3
	II	760	⑤	2.60	560		
			⑥	2.30	480		41.6
			⑦	2.10	440	47	21.8
			⑧	2.30	480	47	28.3
	III	570	⑨	1.10	240		
			⑩	0.96	210		24.2
			⑪	0.88	190	40	12.7
			⑫	0.44	80		
	IV	380	⑬	0.40	70		
			⑭	0.39	65	30	6.7

Current values determined at 230V

Fan ordering information

Airflow direction A					
Design	T (without guard grille)	Q (without guard grille)	Q (guard grille suction side)	Q (without guard grille)	Q (guard grille suction side)
Type	FF091-ZIT.DG.A3P1	FF091-ZIQ.DG.A3P1	FF091-ZIQ.DG.A3P1	FF091-ZIQ.DG.A3P1	FF091-ZIQ.DG.A3P1
0-10 V	Article no. 159983	159981	159982	166953	166955
10-0 V	Article no. 159988	159986	159987	166954	166956
Wall ring plate		Wall ring plate made of composite material	Wall ring plate made of composite material	Wall ring plate made of galvanized sheet steel	Wall ring plate made of galvanized sheet steel
Weight kg	16.00	25.70	30.30	29.00	33.80
Supply temperature	-10°C - max 40°C in design with wall ring plate made of composite material				

Control technology

Control module UNIcon Zenec switch



Page 130



Page 158

Design Q - square full bell mouth, without guard grille

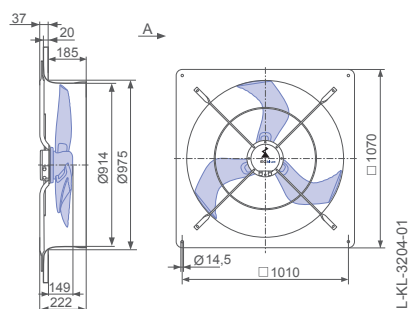

Wall ring plate made of galvanized sheet steel

Design Q - square full bell mouth, guard grille suction side

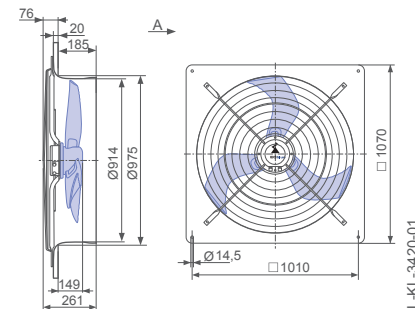

Wall ring plate made of galvanized sheet steel

FFowlet-ECblue with ZAplus

for single phase alternating current, 200-277 V

ZFO91



Description

Motor technology: EC
 Rated voltage U_N : 1~ 200-277 V*
 Rated frequency f_N : 50/60 Hz*
 Input power P_{sys} : 0.86 kW*
 Rated current I_N : 4.20- 3.10 A*
 Rated speed n_N : 910 min⁻¹*
 Thermal class: THCL155*
 Min. permitted ambient temperature $t_{R(min)}$: -35 °C ***
 Max. permitted ambient temperature $t_{R(max)}$: 40 °C
 Electrical connection: Terminal box
 Number of blades: 3
 Degree of protection : IP55
 Motor protection: Integrated active temperature management
 Blades: Aluminium, powder-coated, ultramarine blue
 Rotor: Aluminium, 1 coat paint, ultramarine blue
 Conformity: ErP 2015, CE, UL

ErP-data

Efficiency η_{statA} : 54.5 %
 Efficiency: $N_{actual} = 61.3 / N_{target} = 40^{**}$
 EC controller integrated

* Rated data

**ErP 2015

*** Continuous operation with occasional starts (S1) according to DIN EN 60034-1:2011-02. Occasional starting between -35 °C and -25 °C is permissible. Continuous operation below -25 °C only with special bearings for refrigeration applications on request.

Characteristic curve

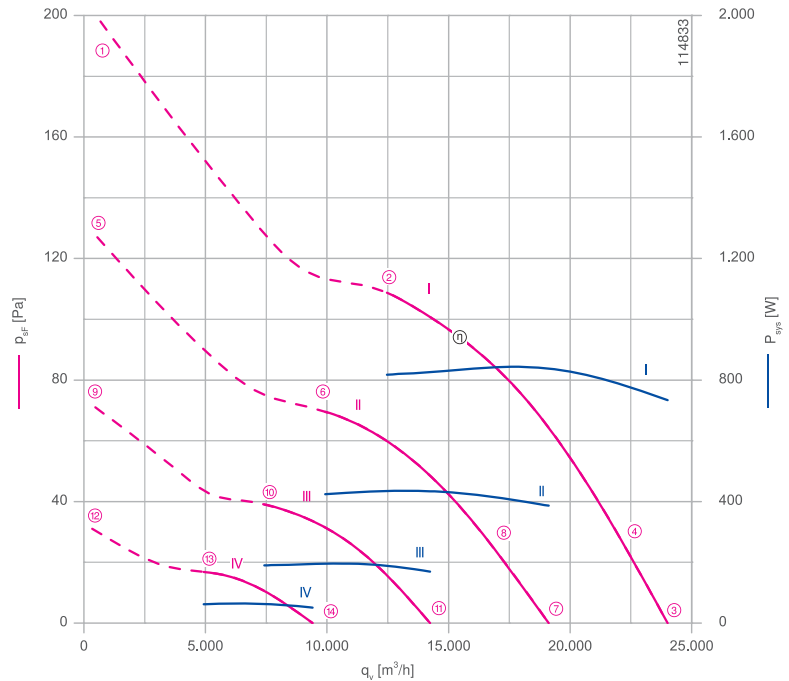

Measured in ZAplus without guard grille in installation type A according to ISO 5801.

Connection diagram Page 173
 0-10 V 1360-389
 Airflow direction V

System components Page 110

Dimensions mm

Airflow direction V

Design L - ZAplus Ontop without guard grille

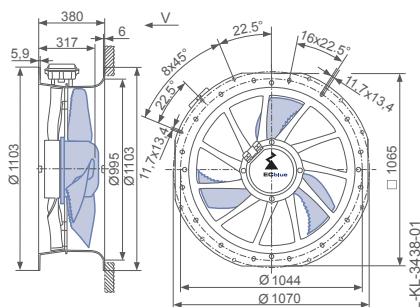

Performance data

Type	Characteristic curve	Speed n min ⁻¹	Operating point	Current	Input power	Acoustic pressure level 7m	Specific power
				I A	P _{sys} W	L _{pA} dB(A)	P _{spez} Wh/1000m ³
ZF091-ZI_DG_3P1	I	910	①	4.80	1100		
			②	3.60	820		66.0
			③	3.20	740	55	30.6
			④	3.50	800	54	36.3
	II	730	⑤	2.40	560		
			⑥	1.90	420		42.9
			⑦	1.75	390	49	20.2
			⑧	1.90	420	49	25.9
	III	550	⑨	1.10	240		
			⑩	0.88	190		25.6
			⑪	0.78	170	42	11.9
	IV	360	⑫	0.40	80		
			⑬	0.54	60		12.8
			⑭	0.48	50	32	5.4

Current values determined at 230V

Fan ordering information

Airflow direction V

Design L (without guard grille)
Ontop



Type ZF091-ZIL.DG.V3P1
Article no. 169861

Weight kg 28.30

Control technology

Control module UNIcon Zenec switch



Page 130



Page 158

FE2owlet-ECblue

for three phase alternating current, 380-480 V

FN 125



Description

Motor technology: EC
 Rated voltage U_N : 3- 380-480 V*
 Rated frequency f_N : 50/60 Hz*
 Input power P_{sys} : 3.10 kW*
 Rated current I_N : 5.00- 3.90 A*
 Rated speed n_N : 680 min⁻¹*
 Thermal class: THCL155*
 Min. permitted ambient temperature $t_{R(min)}$: -35 °C ***
 Max. permitted ambient temperature $t_{R(max)}$: 40 °C
 Electrical connection: Integrated controller
 Number of blades: 3
 Degree of protection : IP55
 Motor protection: Integrated active temperature management
 Blades: Aluminium, powder-coated, ultramarine blue
 Rotor: Aluminium, 2 coat paint, ultramarine blue
 Conformity: ErP 2015, CE, UL

ErP-data

Efficiency η_{statA} : 49.7 %
 Efficiency: $N_{actual} = 53.0 / N_{target} = 40^{**}$
 EC controller integrated

* Rated data

**ErP 2015

*** Continuous operation with occasional starts (S1) according to DIN EN 60034-1:2011-02. Occasional starting between -35 °C and -25 °C is permissible. Continuous operation below -25 °C only with special bearings for refrigeration applications on request.

Characteristic curve

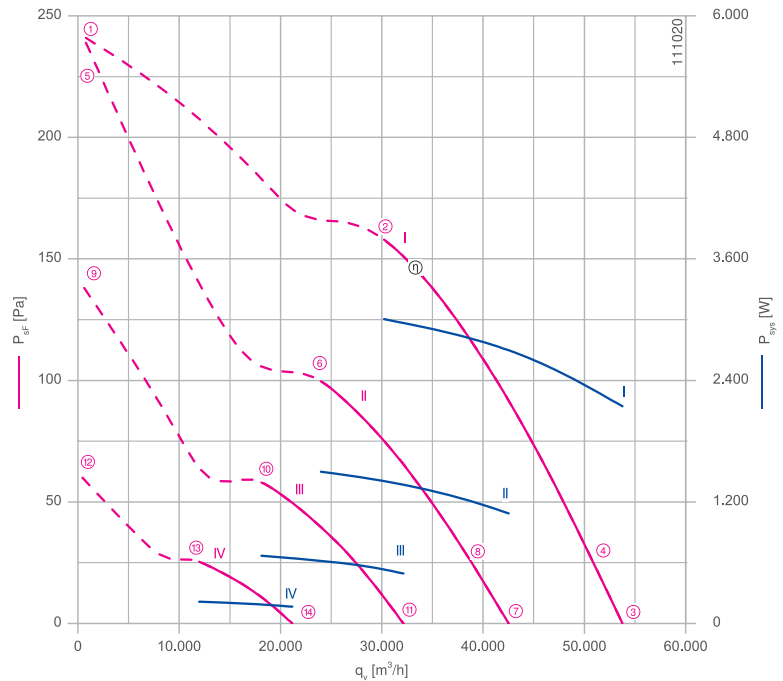

Measured in full bell mouth without guard grille in installation type A according to ISO 5801.

Connection diagram Page 172
1360-403

System components Page 110

Dimensions mm

Airflow direction A

Design T - for installation in chimney exhausts, without guard grille

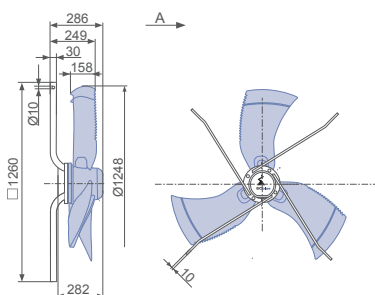

Design L - round full bell mouth, without guard grille

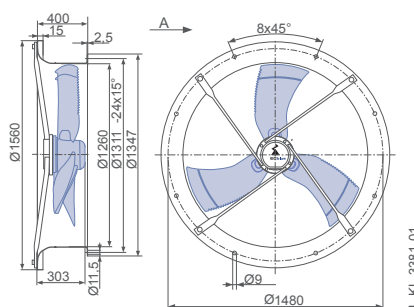

Wall ring plate made of galvanized sheet steel

Design L - round full bell mouth, guard grille suction side

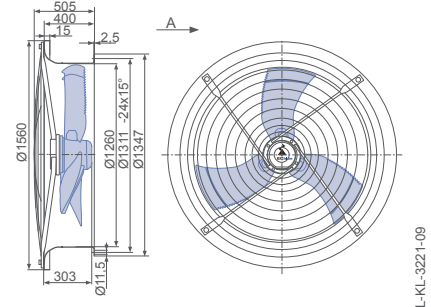

Wall ring plate made of galvanized sheet steel



Performance data

Type	Characteristic curve	Speed n min ⁻¹	Operating point	Current	Input power	Acoustic pressure level 7m	Specific power
				I A	P _{sys} W	L _{pA} dB(A)	P _{spez} Wh/1000m ³
FN125-ZL_GQ...3P1	I	680	①	4.20	2700		
			②	4.60	3000		100.9
			③	3.30	2100	55	39.9
			④	3.60	2400	54	46.7
	II	540	⑤	4.00	2700		
			⑥	2.40	1500		63.2
			⑦	1.80	1100	48	25.6
			⑧	2.00	1250	47	32.6
	III	410	⑨	1.85	1150		
			⑩	1.25	660		36.9
			⑪	1.00	500	40	15.4
	IV	270	⑫	0.82	350		
			⑬	0.64	210		17.9
			⑭	0.56	170	31	7.8

Current values determined at 400V

Fan ordering information

Airflow direction A			
Design	T (without guard grille)	L (without guard grille)	L (guard grille suction side)
			
Type	FN125-ZIT.GQ.A3P1	FN125-ZIL.GQ.A3P1	FN125-ZIL.GQ.A3P1
Article no.	168041	168042	168043
Wall ring plate		Wall ring plate made of galvanized sheet steel	Wall ring plate made of galvanized sheet steel
Weight kg	44.50	89.60	97.30

Control technology

Control module UNIcon Zenec switch



Page 130



Page 158

FC with ZPlus

for single phase alternating current, 4 pole

ZC050-4E



Description

Motor technology: AC
 Rated voltage U_N : 1~ 230 V±10 %*
 Rated frequency f_N : 50 Hz* (60Hz data available)
 Input power P_i : 0.46 kW*
 Rated current I_N : 2.10 A*
 Rated speed n_N : 1220 min⁻¹*
 Starting current I_s : 4.40 A
 Current increase ΔI : 0 %
 Service capacitor C_{400V} : 8.0 μ F
 Thermal class: **THCL155***
 Min. permitted ambient temperature $t_{R(min)}$: -25 °C
 Max. permitted ambient temperature $t_{R(max)}$: 70 °C
 Electrical connection: Terminal box
 Number of blades: 7
 Degree of protection : IP54
 Motor protection: thermal contact
 Blades: Aluminium, 1 coat paint, jet black
 Rotor: Aluminium, 1 coat paint, jet black
 Conformity: ErP 2015, CE

ErP-data

Efficiency η_{statA} : 36.3 %
 Efficiency: $N_{actual} = 44.7 / N_{target} = 40$ **
 * Rated data
 **ErP 2015

Characteristic curve

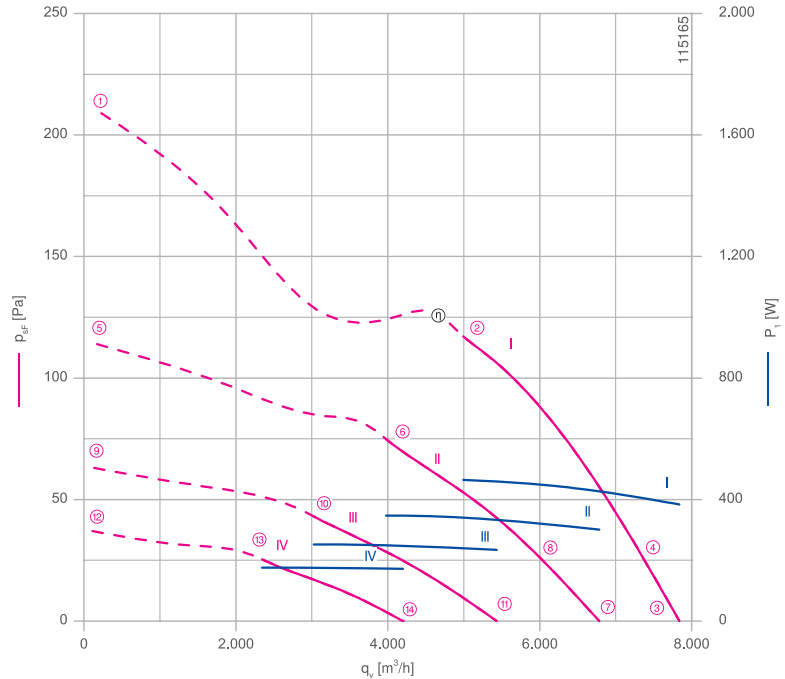

Measured in ZPlus mouth without guard grille in installation type A according to ISO 5801.

Connection diagram Page 174
1360-104XA

System components Page 110

Dimensions mm



Design L - ZPlus Ontop without guard grille

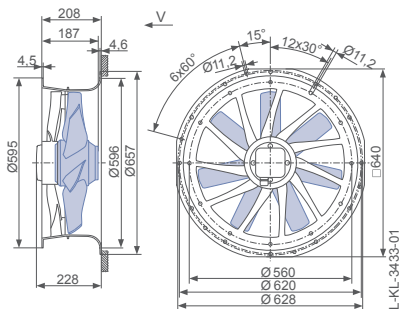

Performance data

Type	Characteristic curve	Voltage	Operating point	Current	Input power	Speed	Acoustic pressure level 7m L_{pA} dB(A)	Specific power P_{spez} Wh/1000m ³
		U V		I A	P_1 W	n min ⁻¹		
ZC050-4E_4F_7	I	230	①	2.50	540	1120		
			②	2.10	460	1220		93.6
			③	1.75	380	1300	52	49.0
			④	1.85	400	1280	51	56.0
	II	170	⑤	2.40	380	830		
			⑥	2.20	350	970		87.8
			⑦	1.85	300	1130	49	44.3
			⑧	2.00	320	1070	48	54.9
	III	135	⑨	2.10	260	620		
			⑩	2.00	250	740		84.0
			⑪	1.85	230	910	45	43.1
	IV	110	⑫	1.80	180	470		
			⑬	1.75	180	570		76.0
			⑭	1.70	170	700	39	40.9

Fan ordering information

Airflow direction V

Design L (without guard grille)
Ontop



Type ZC050-4EL.4F.V7
Article no. 169857

Weight kg 11.50

Control technology

Frequency inverters Fcontrol 1~	Motor protection units 1~	Electronic voltage controllers 1~
		
Page 132	Page 154	Page 138

FFowlet

for single phase alternating current, 6 pole

FF056-6E



Description

Motor technology: AC
 Rated voltage U_N : 1~ 230 V±10 %*
 Rated frequency f_N : 50 Hz* (60Hz data available)
 Input power P_i : 0.40 kW*
 Rated current I_N : 1.90 A*
 Rated speed n_N : 920 min⁻¹*
 Current increase ΔI : 30 %
 Service capacitor C_{400V} : 7.0 μ F
 Thermal class: THCL155*
 Min. permitted ambient temperature $t_{R(min)}$: -25 °C
 Max. permitted ambient temperature $t_{R(max)}$: 45 °C
 Electrical connection: Terminal box
 Number of blades: 5
 Degree of protection : IP54
 Motor protection: thermal contact
 Blades: Aluminium, 2 coat paint, jet black
 Rotor: Aluminium, 2 coat paint, jet black
 Conformity: ErP 2015, CE

ErP-data
 Efficiency η_{statA} : 31.3 %
 Efficiency: $N_{actual} = 40.0 / N_{target} = 40$ **
 * Rated data
 **ErP 2015

Characteristic curve

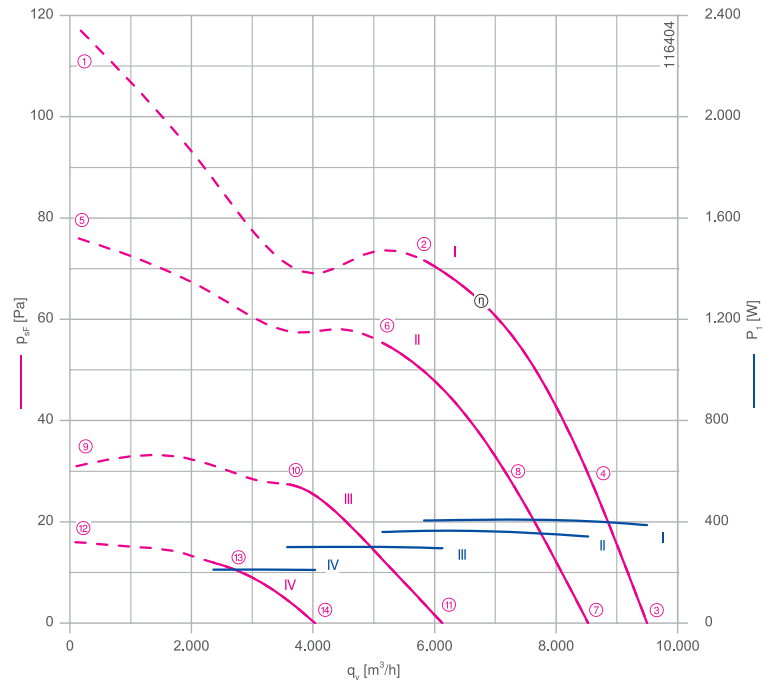

Measured in full bell mouth without guard grille in installation type A according to ISO 5801.

Connection diagram Page 174
1360-104XB

System components Page 110

Dimensions mm

Airflow direction V

Design T - for installation in chimney ex-hausts, without guard grille

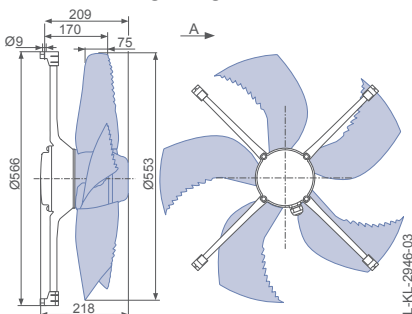

Design Q - square full bell mouth, without guard grille

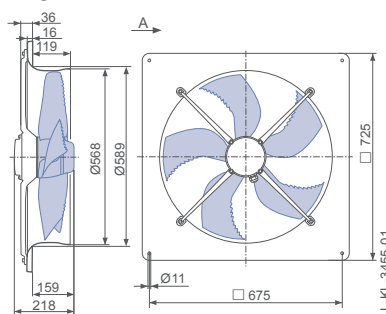

Wall ring plate made of galvanized sheet steel

Design Q - square full bell mouth, guard grille suction side

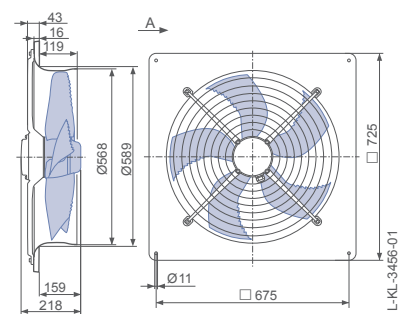

Wall ring plate made of galvanized sheet steel

Performance data

Type	Characteristic curve	Voltage	Operating point	Current	Input power	Speed	Acoustic pressure level 7m L_{pA} dB(A)	Specific power P_{spez} Wh/1000m ³
		U V		I A	P_1 W	n min ⁻¹		
FF056-6E_4I_5R2	I	230	①	2.20	460	900		
			②	1.90	400	920		70.3
			③	1.80	390	930	49	40.8
			④	1.90	400	920	49	47.3
	II	170	⑤	2.70	420	720		
			⑥	2.20	360	810		70.9
			⑦	2.10	340	830	45	40.1
			⑧	2.30	370	800	46	50.7
	III	135	⑨	2.60	310	460		
			⑩	2.50	300	560		84.3
			⑪	2.40	300	600	39	48.2
	IV	110	⑫	2.20	210	330		
			⑬	2.20	210	380		89.5
			⑭	2.20	210	400	30	52.1

Fan ordering information

Airflow direction A

Design	T (without guard grille)	Q (without guard grille)	Q (guard grille suction side)
			
Type	FF056-6ET.4I.A5R2	FF056-6EQ.4I.A5R2	FF056-6EQ.4I.A5R2
Article no.	170492	170491	170515
Wall ring plate		Wall ring plate made of galvanized sheet steel	Wall ring plate made of galvanized sheet steel
Weight kg	11.60	20.60	22.00

Control technology

Frequency inverters Fcontrol 1~	Motor protection units 1~	Electronic voltage controllers 1~
		
Page 132	Page 154	Page 138

FFowlet

for three phase alternating current, 6 pole

FF056-6D



Description

Motor technology: AC
 Rated voltage U_N : 3- 230/400 V (Δ/Y) ± 10 %*
 Rated frequency f_N : 50 Hz* (60Hz data available)
 Input power P_i : 0.39 kW*
 Rated current I_N : 1.50/0.86 A*
 Rated speed n_N : 930 min⁻¹*
 Starting current I_A : 6.00 / 3.60 A
 Current increase ΔI : 5 %
 Thermal class: THCL155*
 Min. permitted ambient temperature $t_{R(min)}$: -40 °C ***
 Max. permitted ambient temperature $t_{R(max)}$: 70 °C
 Electrical connection: Terminal box
 Number of blades: 5
 Degree of protection : IP54
 Motor protection: thermal contact
 Blades: Aluminium, 1 coat paint, jet black
 Rotor: Aluminium, 1 coat paint, jet black
 Conformity: ErP 2015, CE

ErP-data

Efficiency η_{statA} : 34.0 %
 Efficiency: $N_{actual} = 43.0 / N_{target} = 40$ **

* Rated data

**ErP 2015

*** Continuous operation with occasional starts (S1) according to DIN EN 60034-1:2011-02. Occasional starting between -40 °C and -25 °C is permissible. Continuous operation below -25 °C only with special bearings for refrigeration applications on request.

Connection diagram Page 174
1360-106XB

System components Page 110

Characteristic curve

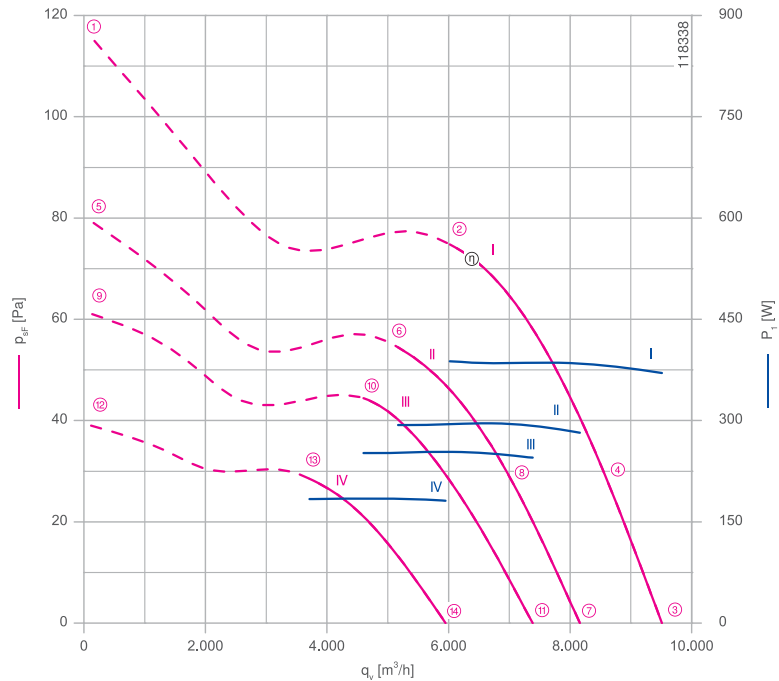

Measured in full bell mouth without guard grille in installation type A according to ISO 5801.

Dimensions mm



Design T - for installation in chimney exhausts, without guard grille

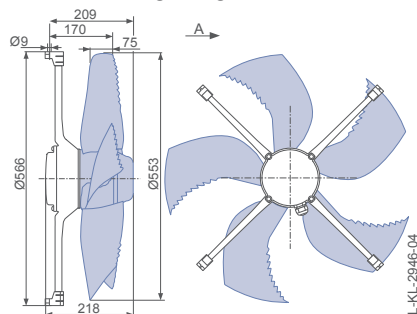

Design Q - square full bell mouth, without guard grille

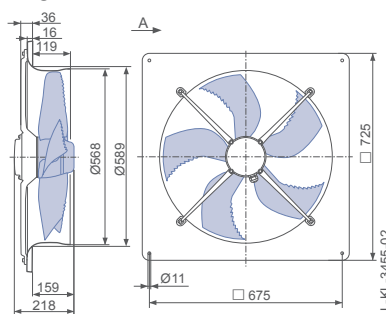

Wall ring plate made of galvanized sheet steel

Design Q - square full bell mouth, guard grille suction side

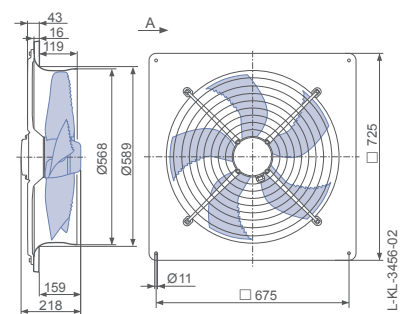

Wall ring plate made of galvanized sheet steel



Performance data

Type	Characteristic curve	Voltage	Operating point	Current	Input power	Speed	Acoustic pressure level 7m L _{pA} dB(A)	Specific power P _{spez} Wh/1000m ³
		U V		I A	P ₁ W	n min ⁻¹		
FF056-6D_4I_5R2	I	400	①	0.90	460	910		
			②	0.82	390	930		64.8
			③	0.84	370	930	48	38.9
			④	0.84	390	930	49	45.1
	II	230	⑤	0.96	330	750		
			⑥	0.88	290	790		57.3
			⑦	0.86	280	810	45	34.5
			⑧	0.88	300	790	46	42.5
	III	190	⑨	0.90	280	660		
			⑩	0.84	250	710		54.7
			⑪	0.82	250	720	43	33.2
	IV	145	⑫	0.68	190	520		
			⑬	0.68	180	580		49.8
			⑭	0.66	180	590	38	30.5

Fan ordering information

Airflow direction A

Design	T (without guard grille)	Q (without guard grille)	Q (guard grille suction side)
			
Type	FF056-GDT.4I.A5R2	FF056-6DQ.4I.A5R2	FF056-6DQ.4I.A5R2
Article no.	171007	171009	171075
Wall ring plate		Wall ring plate made of galvanized sheet steel	Wall ring plate made of galvanized sheet steel
Weight kg	11.60	20.60	22.00

Control technology

<p>Frequency inverters Fcontrol 3~</p>  <p>Page 144</p>	<p>Motor protection units 3~</p>  <p>Page 154</p>	<p>Electronic voltage controllers 3~</p>  <p>Page 150</p>
--	--	--

FFowlet

for single phase alternating current, 6 pole

FF063-6E



Description

Motor technology: AC
 Rated voltage U_N : 1~ 230 V \pm 10 %*
 Rated frequency f_N : 50 Hz* (60Hz data available)
 Input power P_i : 0.52 kW*
 Rated current I_N : 2.50 A*
 Rated speed n_N : 890 min⁻¹*
 Starting current I_A : 5.50 A
 Current increase ΔI : 5 %
 Service capacitor C_{400V} : 10.0 μ F
 Thermal class: **THCL155***
 Min. permitted ambient temperature $t_{R(min)}$: -25 °C
 Max. permitted ambient temperature $t_{R(max)}$: 70 °C
 Electrical connection: Terminal box
 Number of blades: 5
 Degree of protection : IP54
 Motor protection: thermal contact
 Blades: Aluminium, 1 coat paint, jet black
 Rotor: Aluminium, 1 coat paint, jet black
 Conformity: ErP 2015, CE

ErP-data

Efficiency η_{statA} : 32.1 %
 Efficiency: $N_{actual} = 40.3 / N_{target} = 40$ **
 * Rated data
 **ErP 2015

Characteristic curve

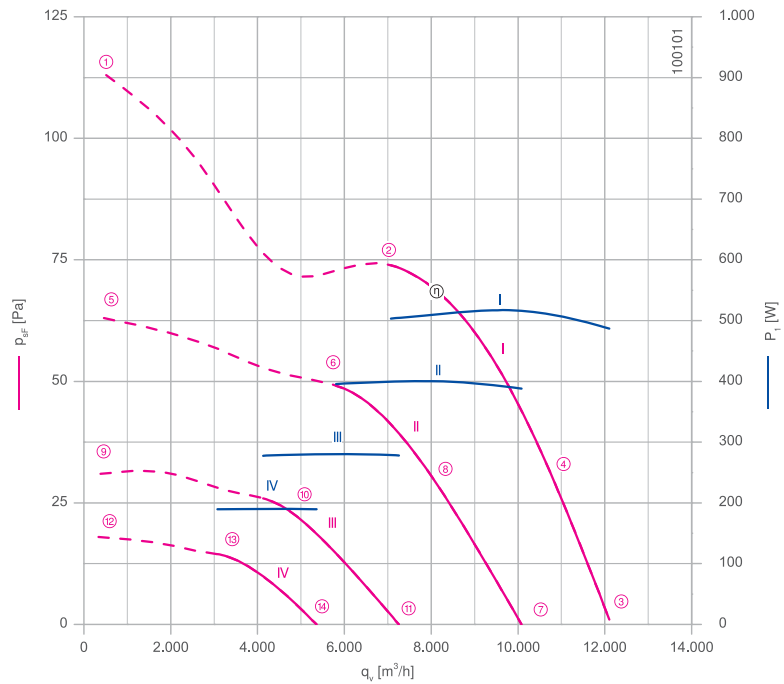

Measured in full bell mouth without guard grille in installation type A according to ISO 5801.

Connection diagram Page 174
1360-104XB

System components Page 110

Dimensions mm

Airflow direction A

Design T - for installation in chimney ex-hausts, without guard grille

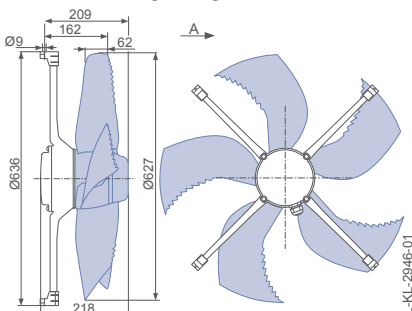

Design Q - square full bell mouth, without guard grille

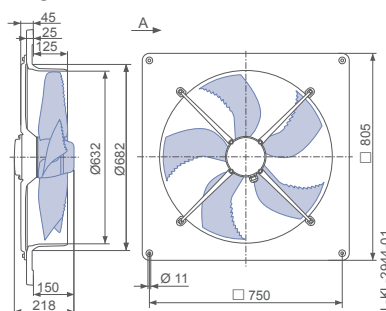

Wall ring plate made of composite material

Design Q - square full bell mouth, guard grille suction side

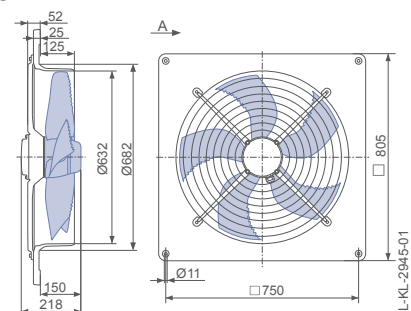

Wall ring plate made of composite material



Performance data

Type	Characteristic curve	Voltage	Operating point	Current	Input power	Speed	Acoustic pressure level 7m L_{pA} dB(A)	Specific power P_{spez} Wh/1000m ³
		U V		I A	P_1 W	n min ⁻¹		
FF063-6E_4I_5R2	I	230	①	2.80	580	860		
			②	2.40	500	900		71.6
			③	2.30	480	900	45	40.2
			④	2.40	520	890	46	47.4
	II	170	⑤	2.80	420	650		
			⑥	2.50	400	740		68.9
			⑦	2.50	390	750	42	38.5
			⑧	2.60	400	720	43	50.1
	III	135	⑨	2.40	280	460		
			⑩	2.40	280	540		67.1
			⑪	2.40	280	540	37	38.3
	IV	110	⑫	2.10	190	350		
			⑬	2.00	190	400		61.2
			⑭	2.00	190	410	32	35.4

Fan ordering information

Airflow direction A 

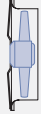
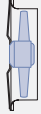
Design	T (without guard grille)	Q (without guard grille)	Q (guard grille suction side)
			
Type	FF063-6ET.4I.A5R2	FF063-6EQ.4I.A5R2	FF063-6EQ.4I.A5R2
Article no.	159968	159966	159967
Wall ring plate		Wall ring plate made of composite material	Wall ring plate made of composite material
Weight kg	12.00	17.20	19.00
Supply temperature -10°C - max 40°C in design with wall ring plate made of composite material			

Control technology

Frequency inverters Control 1~	Motor protection units 1~	Electronic voltage controllers 1~
		
Page 132	Page 154	Page 138

FFowlet with ZAplus

for single phase alternating current, 6 pole

ZF063-6E



Description

Motor technology: AC
 Rated voltage U_N : 1~ 230 V \pm 10 %*
 Rated frequency f_N : 50 Hz* (60Hz data available)
 Input power P_i : 0.52 kW*
 Rated current I_N : 2.50 A*
 Rated speed n_N : 890 min⁻¹*
 Starting current I_A : 5.50 A
 Current increase ΔI : 5 %
 Service capacitor C_{400V} : 10.0 μ F
 Thermal class: THCL155*
 Min. permitted ambient temperature $t_{R(min)}$: -25 °C
 Max. permitted ambient temperature $t_{R(max)}$: 65 °C
 Electrical connection: Terminal box
 Number of blades: 5
 Degree of protection : IP54
 Motor protection: thermal contact
 Blades: Aluminium, 1 coat paint, jet black
 Rotor: Aluminium, 1 coat paint, jet black
 Conformity: ErP 2015, CE

ErP-data

Efficiency η_{statA} : 35.1 %
 Efficiency: $N_{actual} = 43.2 / N_{target} = 40$ **
 * Rated data
 **ErP 2015

Characteristic curve

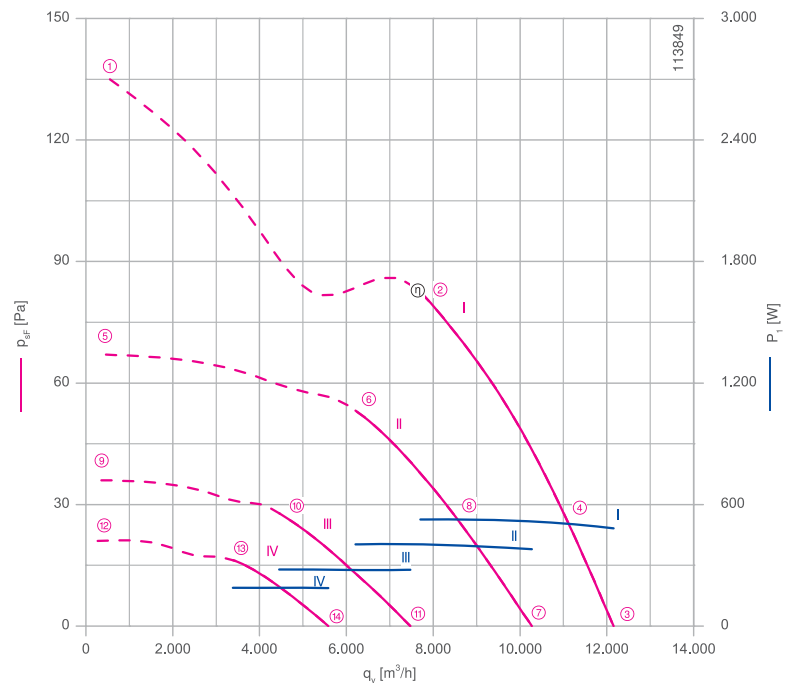

Measured in ZAplus without guard grille in installation type A according to ISO 5801.

Connection diagram Page 174
1360-104XA

System components Page 110

Dimensions mm



Design L - ZAplus Ontop without guard grille

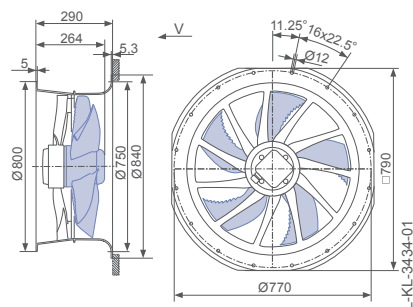

Performance data

Type	Characteristic curve	Voltage	Operating point	Current	Input power	Speed	Acoustic pressure level 7m L_{pA} dB(A)	Specific power P_{spez} Wh/1000m ³
		U V		I A	P_1 W	n min ⁻¹		
ZF063-6E_4I_5R2	I	230	①	3.00	640	820		
			②	2.50	520	890		68.8
			③	2.30	480	900	47	39.7
			④	2.40	520	890	47	46.8
	II	170	⑤	2.90	440	580		
			⑥	2.60	400	710		65.5
			⑦	2.40	380	760	43	36.9
			⑧	2.60	400	710	42	48.5
	III	135	⑨	2.40	290	420		
			⑩	2.30	280	520		63.1
			⑪	2.30	280	570	37	37.2
	IV	110	⑫	2.00	190	330		
			⑬	2.00	190	390		55.9
			⑭	2.00	190	420	32	33.7

Fan ordering information

Airflow direction V

Design L (without guard grille)
Ontop



Type ZF063-6EL.4I.V5R2
Article no. 169858

Weight kg 18.60

Control technology

Frequency inverters Fcontrol 1~	Motor protection units 1~	Electronic voltage controllers 1~
		
Page 132	Page 154	Page 138

FFowlet

for three phase alternating current, 6 pole

FF063-6D



Description

Motor technology: AC
 Rated voltage U_N : 3- 230/400 V (Δ/Y) ± 10 %*
 Rated frequency f_N : 50 Hz* (60Hz data available)
 Input power P_i : 0.54 kW*
 Rated current I_N : 2.20/1.25 A*
 Rated speed n_N : 930 min⁻¹*
 Starting current I_A : 8,50 / 5,00 A
 Current increase ΔI : 0 %
 Thermal class: **THCL155***
 Min. permitted ambient temperature $t_{R(min)}$: -40 °C ***
 Max. permitted ambient temperature $t_{R(max)}$: 70 °C
 Electrical connection: Terminal box
 Number of blades: 5
 Degree of protection : IP54
 Motor protection: thermal contact
 Blades: Aluminium, 1 coat paint, jet black
 Rotor: Aluminium, 1 coat paint, jet black
 Conformity: ErP 2015, CE

ErP-data

Efficiency η_{statA} : 34.0 %
 Efficiency: $N_{actual} = 42.2 / N_{target} = 40$ **

* Rated data

**ErP 2015

*** Continuous operation with occasional starts (S1) according to DIN EN 60034-1:2011-02. Occasional starting between -40 °C and -25 °C is permissible. Continuous operation below -25 °C only with special bearings for refrigeration applications on request.

Connection diagram Page 174
1360-106XB

System components Page 110

Dimensions mm

Airflow direction A

Design T - for installation in chimney exhausts, without guard grille

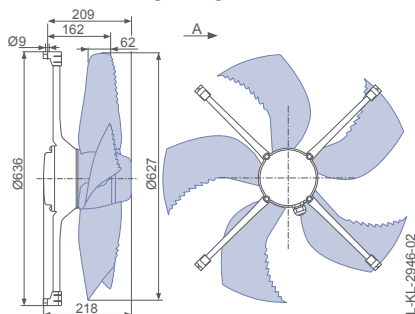

Design Q - square full bell mouth, without guard grille

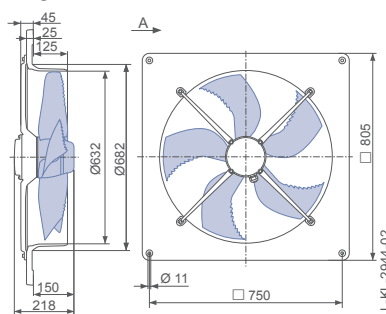

Wall ring plate made of composite material

Design Q - square full bell mouth, guard grille suction side

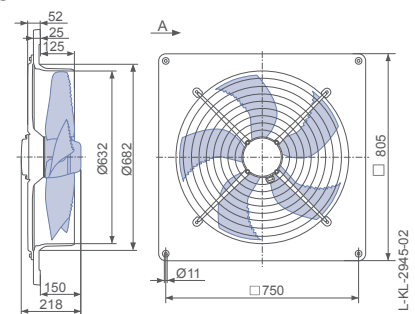

Wall ring plate made of composite material

Characteristic curve

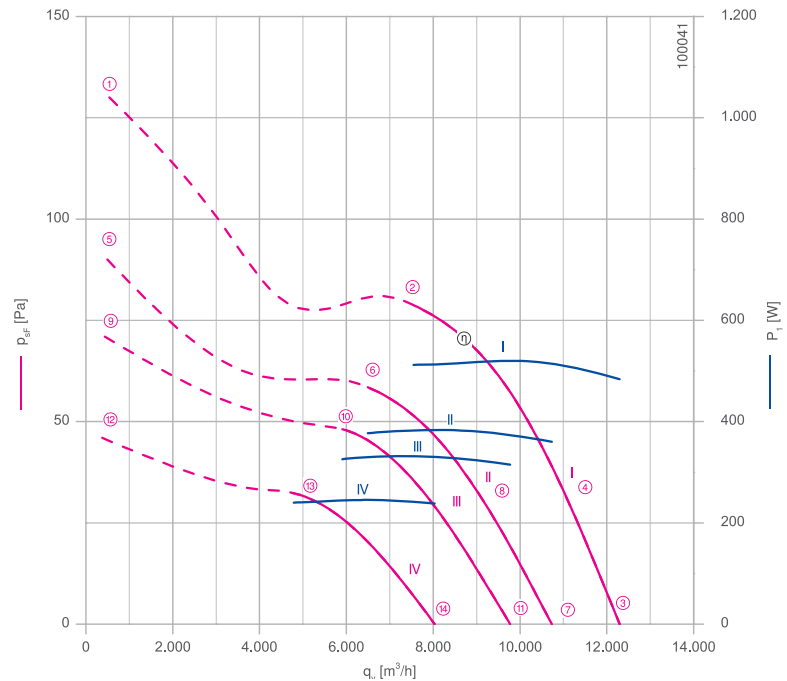

Measured in full bell mouth without guard grille in installation type A according to ISO 5801.



Performance data

Type	Characteristic curve	Voltage	Operating point	Current	Input power	Speed	Acoustic pressure level 7m L_{pA} dB(A)	Specific power P_{spez} Wh/1000m ³
		U V		I A	P_1 W	n min ⁻¹		
FF063-6D_4I_5R2	I	400	①	1.35	600	910		
			②	1.25	520	930		68.2
			③	1.25	480	940	46	39.3
			④	1.25	520	930	46	45.8
	II	230	⑤	1.25	440	760		
			⑥	1.10	380	810		58.4
			⑦	1.10	360	820	43	33.6
			⑧	1.15	380	800	44	41.5
			⑨	1.25	360	680		
			⑩	1.15	330	730		
	III	190	⑪	1.10	320	750	42	32.2
			⑫	1.20	260	550		
			⑬	1.10	240	600		50.0
			⑭	1.10	240	620	38	29.6

Fan ordering information

Airflow direction A

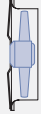
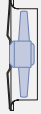
Design	T (without guard grille)	Q (without guard grille)	Q (guard grille suction side)
			
Type	FF063-6DT.4I.A5R2	FF063-6DQ.4I.A5R2	FF063-6DQ.4I.A5R2
Article no.	159958	159956	159957
Wall ring plate		Wall ring plate made of composite material	Wall ring plate made of composite material
Weight kg	12.00	17.20	19.00
Supply temperature -10°C - max 40°C in design with wall ring plate made of composite material			

Control technology

Frequency inverters Fcontrol 3~	Motor protection units 3~	Electronic voltage controllers 3~
		
Page 144	Page 154	Page 150

FFowlet

for three phase alternating current, 6 pole

FFO71-6D



Description

Motor technology: AC
 Rated voltage U_N : 3- 230/400 V (Δ/Y) ± 10 %*
 Rated frequency f_N : 50 Hz* (60Hz data available)
 Input power P_i : 0.60 kW*
 Rated current I_N : 2.70/1.55 A*
 Rated speed n_N : 940 min⁻¹*
 Starting current I_A : 10.00 / 6.00 A
 Current increase ΔI : 0 %
 Thermal class: THCL155*
 Min. permitted ambient temperature $t_{R(min)}$: -40 °C ***
 Max. permitted ambient temperature $t_{R(max)}$: 70 °C
 Electrical connection: Terminal box
 Number of blades: 3
 Degree of protection : IP54
 Motor protection: thermal contact
 Blades: Aluminium, 1 coat paint, jet black
 Rotor: Aluminium, 1 coat paint, jet black
 Conformity: ErP 2015, CE

ErP-data

Efficiency η_{statA} : 38.4 %
 Efficiency: $N_{actual} = 46.2 / N_{target} = 40$ **

* Rated data

**ErP 2015

*** Continuous operation with occasional starts (S1) according to DIN EN 60034-1:2011-02. Occasional starting between -40 °C and -25 °C is permissible. Continuous operation below -25 °C only with special bearings for refrigeration applications on request.

Characteristic curve

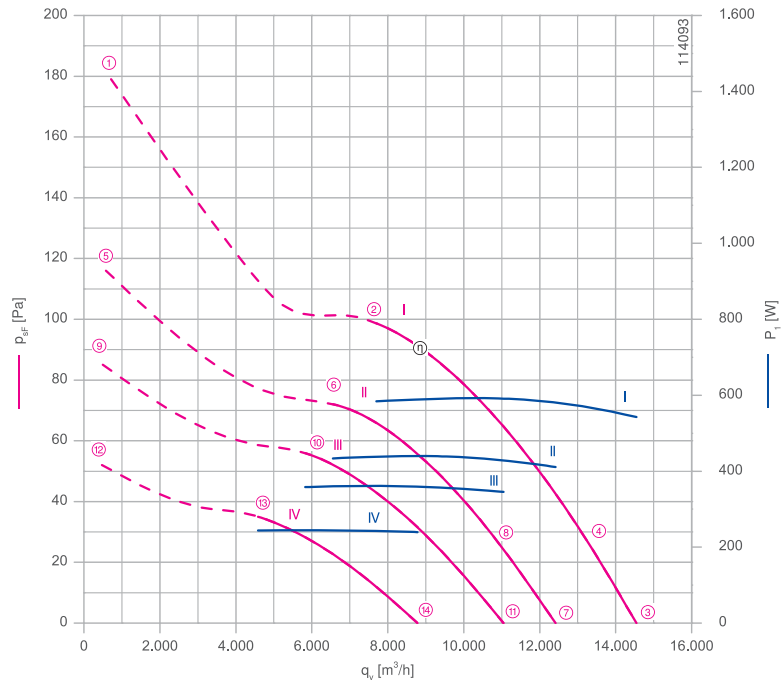

Measured in full bell mouth without guard grille in installation type A according to ISO 5801.

Connection diagram Page 174
1360-106XB

System components Page 110

Dimensions mm

Airflow direction A

Design T - for installation in chimney exhausts, without guard grille

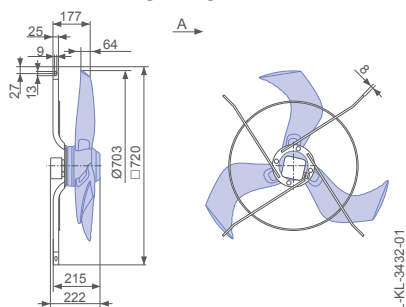

Design Q - square full bell mouth, without guard grille

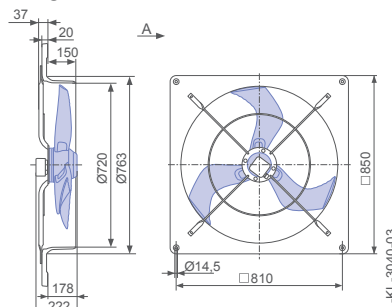

Design Q - square full bell mouth, guard grille suction side

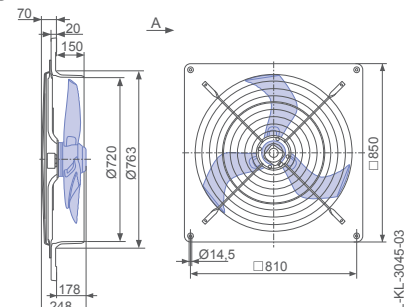

Wall ring plate made of galvanized sheet steel

Wall ring plate made of galvanized sheet steel



Performance data

Type	Characteristic curve	Voltage	Operating point	Current	Input power	Speed	Acoustic pressure level 7m L _{pA} dB(A)	Specific power P _{spez} Wh/1000m ³
		U V		I A	P ₁ W	n min ⁻¹		
FF071-6D_.6F_.3P2	I	400	①	1.70	720	920		
			②	1.55	580	940		76.4
			③	1.50	540	940	51	37.3
			④	1.55	580	940	49	43.8
	II	230	⑤	1.70	500	740		
			⑥	1.45	440	800		66.5
			⑦	1.35	420	820	47	33.1
			⑧	1.45	440	800	46	40.3
	III	190	⑨	1.65	390	630		
			⑩	1.45	360	710		62.1
			⑪	1.40	350	730	45	31.3
	IV	145	⑫	1.40	250	490		
			⑬	1.35	240	560		53.5
			⑭	1.30	240	580	40	27.3

Fan ordering information

Airflow direction A →

Design	T (without guard grille)	Q (without guard grille)	Q (guard grille suction side)
			
Type	FF071-6DT.6F.A3P2	FF071-6DQ.6F.A3P2	FF071-6DQ.6F.A3P2
Article no.	169735	169731	169734
Wall ring plate		Wall ring plate made of galvanized sheet steel	Wall ring plate made of galvanized sheet steel
Weight kg	17.90	29.30	32.80

Control technology

<p>Frequency inverters Fcontrol 3~</p>  <p>Page 144</p>	<p>Motor protection units 3~</p>  <p>Page 154</p>	<p>Electronic voltage controllers 3~</p>  <p>Page 150</p>
--	--	--

FFowlet

for single phase alternating current, 6 pole

FF080-6E



Description

Motor technology: AC
 Rated voltage U_N : 1~ 230 V \pm 10 %*
 Rated frequency f_N : 50 Hz*
 Input power P_i : 0.76 kW*
 Rated current I_N : 3.40 A*
 Rated speed n_N : 880 min⁻¹*
 Current increase ΔI : 0 %
 Service capacitor C_{400V} : 16.0 μ F
 Thermal class: THCL155*
 Min. permitted ambient temperature $t_{R(min)}$: -25 °C
 Max. permitted ambient temperature $t_{R(max)}$: 55 °C
 Electrical connection: Terminal box
 Number of blades: 3
 Degree of protection : IP54
 Motor protection: thermal contact
 Blades: Aluminium, 1 coat paint, jet black
 Rotor: Aluminium, 1 coat paint, jet black
 Conformity: ErP 2015, CE

ErP-data

Efficiency η_{statA} : 35.9 %
 Efficiency: $N_{actual} = 43.0 / N_{target} = 40$ **
 * Rated data
 **ErP 2015

Characteristic curve

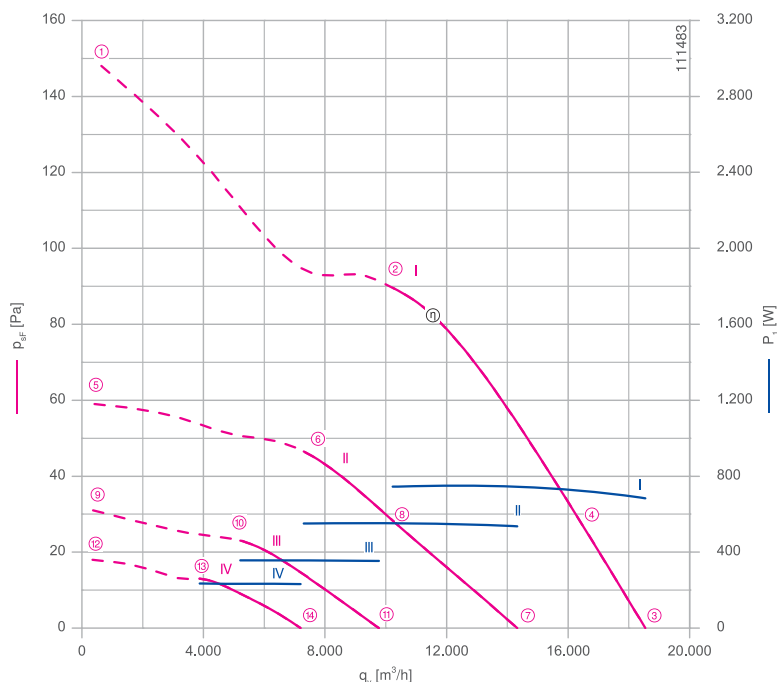

Measured in full bell mouth without guard grille in installation type A according to ISO 5801.

Connection diagram Page 174
1360-104XB

System components Page 110

Dimensions mm

Airflow direction A

Design T - for installation in chimney ex-hausts, without guard grille

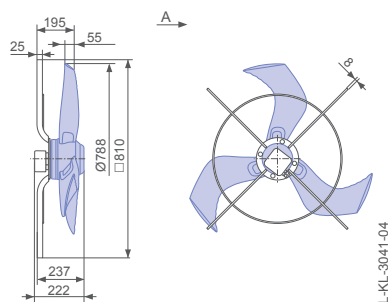

Design Q - square full bell mouth, without guard grille

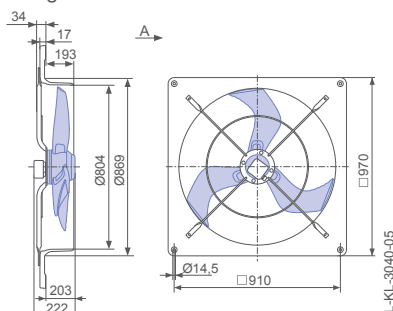

Wall ring plate made of galvanized sheet steel

Design Q - square full bell mouth, guard grille suction side

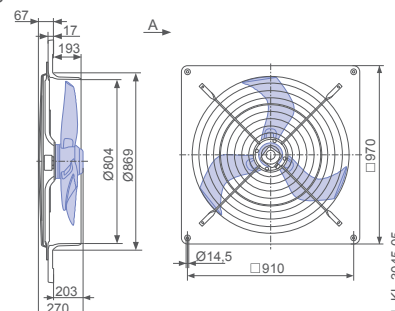

Wall ring plate made of galvanized sheet steel



Performance data

Type	Characteristic curve	Voltage	Operating point	Current	Input power	Speed	Acoustic pressure level 7m L _{pA} dB(A)	Specific power P _{spez} Wh/1000m ³
		U V		I A	P ₁ W	n min ⁻¹		
FF080-6E_.6F_.3P2	I	230	①	4.20	900	810		
			②	3.40	740	890		73.5
			③	3.10	680	910	50	36.9
			④	3.30	720	890	50	44.7
	II	170	⑤	3.90	560	510		
			⑥	3.70	560	640		75.6
			⑦	3.60	540	700	44	37.4
			⑧	3.70	560	630	45	55.4
	III	135	⑨	3.20	360	370		
			⑩	3.10	360	450		69.3
			⑪	3.10	350	490	37	36.2
	IV	110	⑫	2.60	240	290		
			⑬	2.60	230	340		60.8
			⑭	2.50	230	360	31	32.3

Fan ordering information

Airflow direction A →

Design	T (without guard grille)	Q (without guard grille)	Q (guard grille suction side)
			
Type	FF080-6ET.6F.A3P2	FF080-6EQ.6F.A3P2	FF080-6EQ.6F.A3P2
Article no.	169856	169854	169855
Wall ring plate		Wall ring plate made of galvanized sheet steel	Wall ring plate made of galvanized sheet steel
Weight kg	18.50	33.80	37.70

Control technology

Frequency inverters Fcontrol 1~	Motor protection units 1~	Electronic voltage controllers 1~
		
Page 132	Page 154	Page 138

FFowlet

for three phase alternating current, 6 pole

FF080-6D



Description

Motor technology: AC
 Rated voltage U_N : 3- 230/400 V (Δ/Y) ± 10 %*
 Rated frequency f_N : 50 Hz* (60Hz data available)
 Input power P_i : 0.76 kW*
 Rated current I_N : 3.10/1.80 A*
 Rated speed n_N : 920 min⁻¹*
 Starting current I_A : 10.00 / 6.00 A
 Current increase ΔI : 0 %
 Thermal class: THCL155*
 Min. permitted ambient temperature $t_{R(min)}$: -40 °C ***
 Max. permitted ambient temperature $t_{R(max)}$: 45 °C
 Electrical connection: Terminal box
 Number of blades: 3
 Degree of protection : IP54
 Motor protection: thermal contact
 Blades: Aluminium, 1 coat paint, jet black
 Rotor: Aluminium, 1 coat paint, jet black
 Conformity: ErP 2015, CE

ErP-data

Efficiency η_{statA} : 40.5 %
 Efficiency: $N_{actual} = 47.6 / N_{target} = 40$ **

* Rated data

**ErP 2015

*** Continuous operation with occasional starts (S1) according to DIN EN 60034-1:2011-02. Occasional starting between -40 °C and -25 °C is permissible. Continuous operation below -25 °C only with special bearings for refrigeration applications on request.

Connection diagram Page 174
1360-106XB

System components Page 110

Dimensions mm

Airflow direction A

Design T - for installation in chimney exhausts, without guard grille

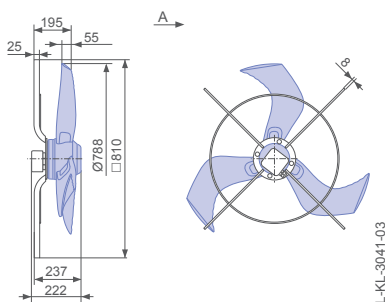

Design Q - square full bell mouth, without guard grille

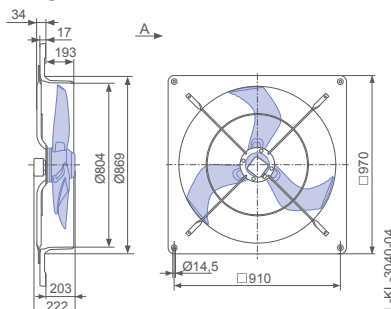

Wall ring plate made of galvanized sheet steel

Design Q - square full bell mouth, guard grille suction side

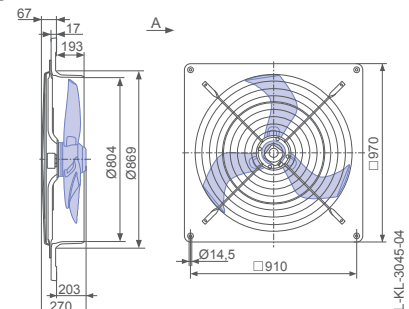

Wall ring plate made of galvanized sheet steel

Characteristic curve

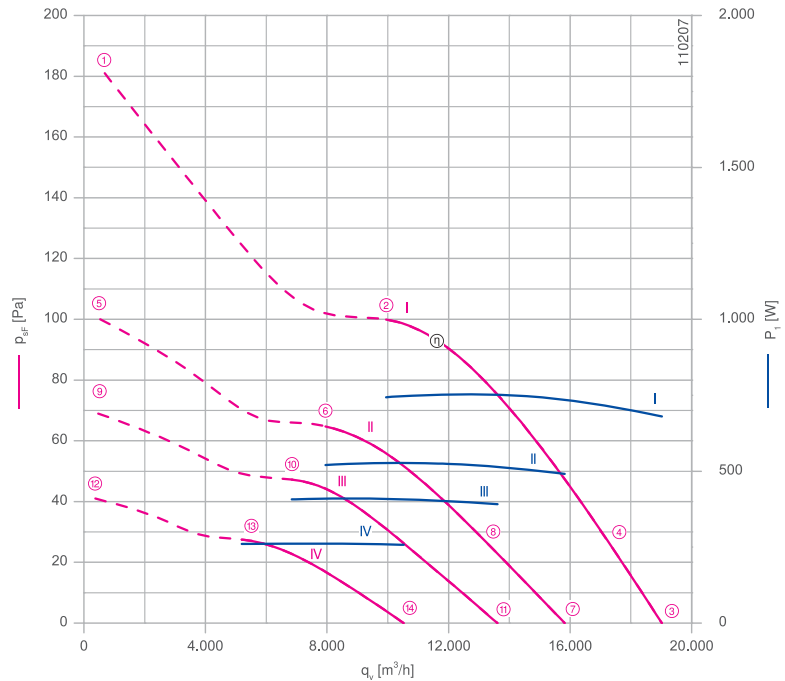

Measured in full bell mouth without guard grille in installation type A according to ISO 5801.



Performance data

Type	Characteristic curve	Voltage	Operating point	Current	Input power	Speed	Acoustic pressure level 7m L_{pA} dB(A)	Specific power P_{spez} Wh/1000m ³
		U V		I A	P_1 W	n min ⁻¹		
FF080-6D_6F_3P2	I	400	①	2.10	940	890		
			②	1.95	740	920		75.1
			③	1.80	680	930	50	35.8
			④	1.80	720	930	50	42.5
	II	230	⑤	2.00	580	660		
			⑥	1.75	520	750		65.5
			⑦	1.65	500	780	46	31.0
			⑧	1.75	520	750	47	40.4
	III	190	⑨	1.85	440	560		
			⑩	1.70	400	640		60.1
			⑪	1.60	390	670	43	28.8
	IV	145	⑫	1.55	270	420		
			⑬	1.50	260	490		50.3
			⑭	1.45	260	520	38	24.5

Fan ordering information

Airflow direction A →

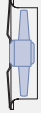
Design	T (without guard grille)	Q (without guard grille)	Q (guard grille suction side)
			
Type	FF080-6DT.6F.A3P2	FF080-6DQ.6F.A3P2	FF080-6DQ.6F.A3P2
Article no.	169851	169849	169850
Wall ring plate		Wall ring plate made of galvanized sheet steel	Wall ring plate made of galvanized sheet steel
Weight kg	18.50	33.80	37.70

Control technology

Frequency inverters Fcontrol 3~	Motor protection units 3~	Electronic voltage controllers 3~
		
Page 144	Page 154	Page 150

FFowlet

for single phase alternating current, 6 pole

FF091-6E



Description

Motor technology: AC
 Rated voltage U_N : 1~ 230 V \pm 10 %*
 Rated frequency f_N : 50 Hz*
 Input power P_i : 0.94 kW*
 Rated current I_N : 4.20 A*
 Rated speed n_N : 840 min⁻¹*
 Current increase ΔI : 0 %
 Service capacitor C_{400V} : 20.0 μ F
 Thermal class: THCL155*
 Min. permitted ambient temperature $t_{R(min)}$: -25 °C
 Max. permitted ambient temperature $t_{R(max)}$: 55 °C
 Electrical connection: Terminal box
 Number of blades: 3
 Degree of protection : IP54
 Motor protection: thermal contact
 Blades: Aluminium, 1 coat paint, jet black
 Rotor: Aluminium, 1 coat paint, jet black
 Conformity: ErP 2015, CE

ErP-data
 Efficiency η_{statA} : 34.2 %
 Efficiency: $N_{actual} = 40.8 / N_{target} = 40^{**}$
 * Rated data
 **ErP 2015

Characteristic curve

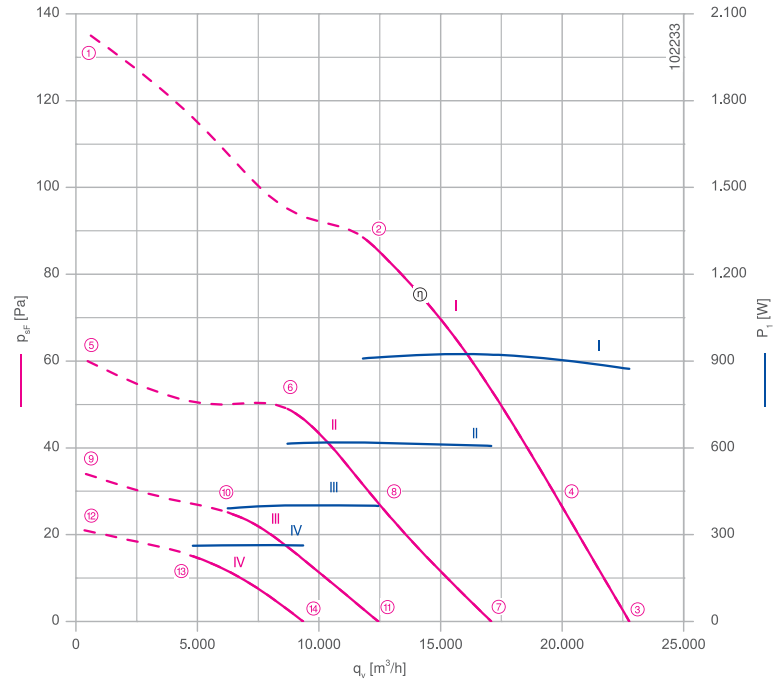

Measured in full bell mouth without guard grille in installation type A according to ISO 5801.

Connection diagram Page 174
1360-104XB

System components Page 110

Dimensions mm

Airflow direction A

Design T - for installation in chimney ex-hausts, without guard grille

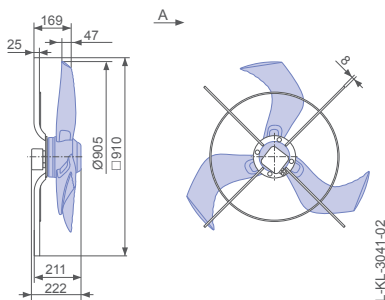

Design Q - square full bell mouth, without guard grille

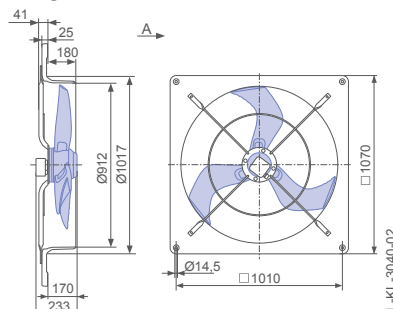

Wall ring plate made of composite material

Design Q - square full bell mouth, guard grille suction side

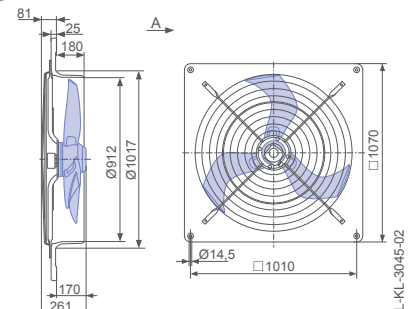

Wall ring plate made of composite material





Performance data

Type	Characteristic curve	Voltage	Operating point	Current	Input power	Speed	Acoustic pressure level 7m L _{pA} dB(A)	Specific power P _{spez} Wh/1000m ³
		U V		I A	P ₁ W	n min ⁻¹		
FF091-6E_6F_3P2	I	230	①	4.60	1000	780		
			②	4.00	900	850		77.8
			③	3.80	880	870	50	38.4
			④	4.00	900	840	49	46.4
	II	170	⑤	4.00	620	520		
			⑥	3.80	620	630		70.9
			⑦	3.80	600	650	44	35.5
			⑧	3.90	620	610	45	52.0
	III	135	⑨	3.30	390	390		
			⑩	3.20	390	450		63.0
			⑪	3.20	400	480	36	32.1
	IV	110	⑫	2.70	260	310		
			⑬	2.70	260	360		54.6
			⑭	2.70	260	370	31	28.1

Fan ordering information

Airflow direction A →

Design	T (without guard grille)	Q (without guard grille)	Q (guard grille suction side)
			
Type	FF091-6ET.6F.A3P2	FF091-6EQ.6F.A3P2	FF091-6EQ.6F.A3P2
Article no.	159998	159996	159997
Wall ring plate		Wall ring plate made of composite material	Wall ring plate made of composite material
Weight kg	19.50	29.10	34.20
Supply temperature -10°C - max 40°C in design with wall ring plate made of composite material			

Control technology

Frequency inverters Fcontrol 1~	Motor protection units 1~	Electronic voltage controllers 1~
		
Page 132	Page 154	Page 138

FFowlet

for three phase alternating current, 6 pole

FF091-6D



Description

Motor technology: AC
 Rated voltage U_N : 3- 230/400 V (Δ/Y) ± 10 %*
 Rated frequency f_N : 50 Hz* (60Hz data available)
 Input power P_i : 0.92 kW*
 Rated current I_N : 3.30/1.90 A*
 Rated speed n_N : 880 min⁻¹*
 Starting current I_A : 10.00 / 6.00 A
 Current increase ΔI : 0 %
 Thermal class: THCL155*
 Min. permitted ambient temperature $t_{R(min)}$: -40 °C ***
 Max. permitted ambient temperature $t_{R(max)}$: 70 °C
 Electrical connection: Terminal box
 Number of blades: 3
 Degree of protection : IP54
 Motor protection: thermal contact
 Blades: Aluminium, 1 coat paint, jet black
 Rotor: Aluminium, 1 coat paint, jet black
 Conformity: ErP 2015, CE

ErP-data

Efficiency η_{statA} : 40.3 %
 Efficiency: $N_{actual} = 46.9 / N_{target} = 40$ **

* Rated data

**ErP 2015

*** Continuous operation with occasional starts (S1) according to DIN EN 60034-1:2011-02. Occasional starting between -40 °C and -25 °C is permissible. Continuous operation below -25 °C only with special bearings for refrigeration applications on request.

Characteristic curve

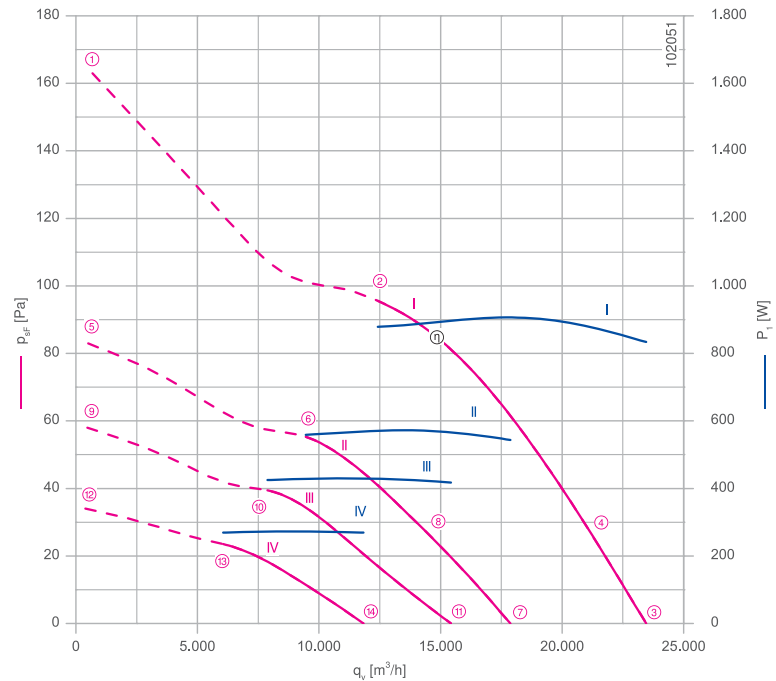

Measured in full bell mouth without guard grille in installation type A according to ISO 5801.

Connection diagram Page 174
1360-106XB

System components Page 110

Dimensions mm

Airflow direction A

Design T - for installation in chimney exhausts, without guard grille

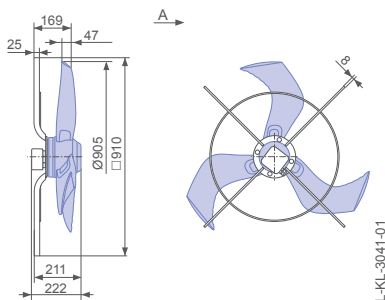

Design Q - square full bell mouth, without guard grille

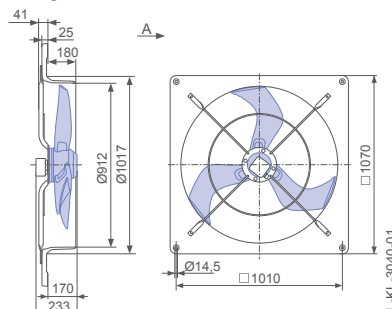

Design Q - square full bell mouth, guard grille suction side

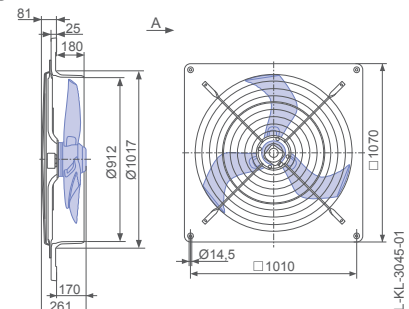

Wall ring plate made of composite material

Wall ring plate made of composite material



Performance data

Type	Characteristic curve	Voltage	Operating point	Current	Input power	Speed	Acoustic pressure level 7m L _{pA} dB(A)	Specific power P _{spez} Wh/1000m ³
		U V		I A	P ₁ W	n min ⁻¹		
FF091-6D_6F_3P2	I	400	①	2.10	1050	860		
			②	1.85	880	890		71.5
			③	1.80	840	900	51	35.5
			④	1.90	880	890	50	42.3
	II	230	⑤	2.00	620	610		
			⑥	1.80	560	680		59.8
			⑦	1.75	540	690	45	30.4
			⑧	1.85	580	660	44	41.1
	III	190	⑨	1.80	440	510		
			⑩	1.70	420	570		54.1
			⑪	1.65	420	590	41	27.0
	IV	145	⑫	1.50	280	390		
			⑬	1.45	270	440		44.4
			⑭	1.45	270	460	35	22.7

Fan ordering information

Airflow direction A 

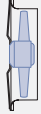
Design	T (without guard grille)	Q (without guard grille)	Q (guard grille suction side)
			
Type	FF091-6DT.6F.A3P2	FF091-6DQ.6F.A3P2	FF091-6DQ.6F.A3P2
Article no.	159993	159991	159992
Wall ring plate		Wall ring plate made of composite material	Wall ring plate made of composite material
Weight kg	19.50	29.10	34.20
Supply temperature -10°C - max 40°C in design with wall ring plate made of composite material			

Control technology

Frequency inverters Fcontrol 3~	Motor protection units 3~	Electronic voltage controllers 3~
		
Page 144	Page 154	Page 150

FFowlet with ZAplus

for three phase alternating current, 6 pole

ZFO91-6D



Description

Motor technology: AC
 Rated voltage U_N : 3- 230/400 V (Δ/Y) ± 10 %*
 Rated frequency f_N : 50 Hz* (60Hz data available)
 Input power P_i : 0.90 kW*
 Rated current I_N : 3.40/1.95 A*
 Rated speed n_N : 890 min⁻¹*
 Starting current I_A : 10.00 / 6.00 A
 Current increase ΔI : 0 %
 Thermal class: THCL155*
 Min. permitted ambient temperature $t_{R(min)}$: -40 °C ***
 Max. permitted ambient temperature $t_{R(max)}$: 70 °C
 Electrical connection: Terminal box
 Number of blades: 3
 Degree of protection : IP54
 Motor protection: thermal contact
 Blades: Aluminium, 1 coat paint, jet black
 Rotor: Aluminium, 1 coat paint, jet black
 Conformity: ErP 2015, CE

ErP-data

Efficiency η_{statA} : 42.6 %
 Efficiency: $N_{actual} = 49.3 / N_{target} = 40$ **

* Rated data

**ErP 2015

*** Continuous operation with occasional starts (S1) according to DIN EN 60034-1:2011-02. Occasional starting between -40 °C and -25 °C is permissible. Continuous operation below -25 °C only with special bearings for refrigeration applications on request.

Connection diagram Page 174
1360-106XA

System components Page 110

Dimensions mm



Design L - ZPlus Ontop without guard grille

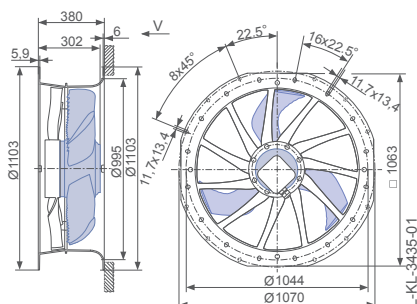

Characteristic curve

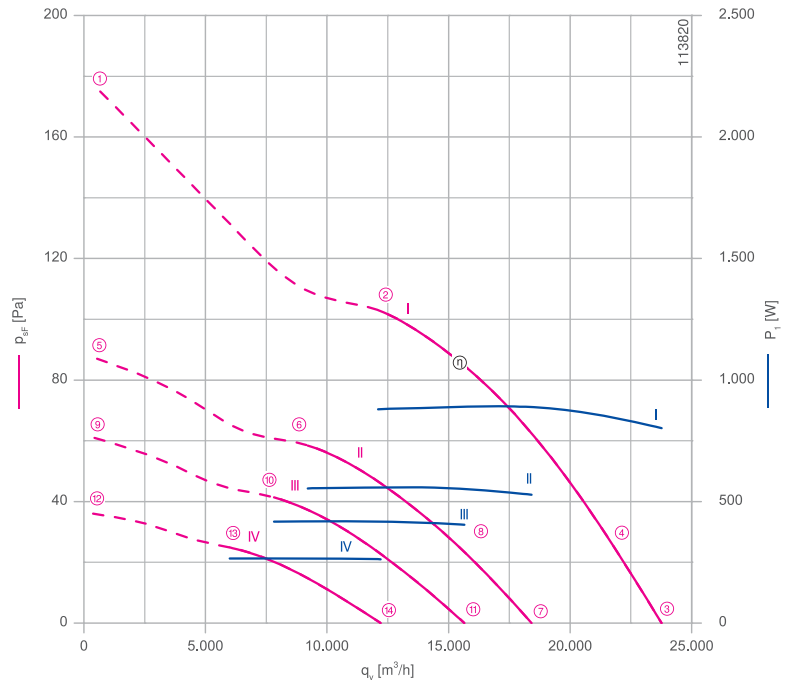

Measured in ZPlus without guard grille in installation type A according to ISO 5801.



Performance data

Type	Characteristic curve	Voltage	Operating point	Current	Input power	Speed	Acoustic pressure level 7m L_{pA} dB(A)	Specific power P_{spez} Wh/1000m ³
		U V		I A	P_1 W	n min ⁻¹		
ZF091-6D_6F_3P2	I	400	①	2.20	1100	850		
			②	1.90	880	890		72.7
			③	1.80	800	900	56	33.8
			④	1.90	860	890	55	39.9
	II	230	⑤	2.00	600	600		
			⑥	1.80	560	670		60.7
			⑦	1.75	520	700	49	28.7
			⑧	1.85	560	670	48	37.8
	III	190	⑨	1.80	440	500		
			⑩	1.70	420	570		54.3
			⑪	1.65	400	600	45	25.9
	IV	145	⑫	1.50	270	390		
			⑬	1.45	270	440		44.7
			⑭	1.40	260	470	39	21.5

Fan ordering information

Airflow direction V

Design L (without guard grille)
Ontop



Type ZF091-6DL.6F.V3P2
Article no. 169697

Weight kg 31.20

Control technology

<p>Frequency inverters Fcontrol 3~</p>  <p>Page 144</p>	<p>Motor protection units 3~</p>  <p>Page 154</p>	<p>Electronic voltage controllers 3~</p>  <p>Page 150</p>
--	--	--

FE2owlet

for three phase alternating current, 10-10 pole

FN125-MD



Description

Motor technology: AC
 Rated voltage U_N : 3- 400 V (Δ/Y) ± 10 %*
 Rated frequency f_N : 50 Hz*
 Input power P_i : 1.95/1.20 kW*
 Rated current I_N : 4.60/2.40 A*
 Rated speed n_N : 530/ 400 min⁻¹*
 Starting current I_A : 14.00 / 4.00 A
 Current increase ΔI : 0 %
 Thermal class: **THCL155***
 Min. permitted ambient temperature $t_{R(min)}$: -40 °C ***
 Max. permitted ambient temperature $t_{R(max)}$: 65 °C
 Electrical connection: Terminal box
 Number of blades: 3
 Degree of protection : IP54
 Motor protection: thermal contact
 Blades: Aluminium, 2 coat paint, jet black
 Rotor: Aluminium, 2 coat paint, jet black
 Conformity: ErP 2015, CE

ErP-data

Efficiency η_{statA} : 35.9 %
 Efficiency: $N_{actual} = 40.5 / N_{target} = 40$ **
 * Rated data
 **ErP 2015

*** Continuous operation with occasional starts (S1) according to DIN EN 60034-1:2011-02. Occasional starting between -40 °C and -25 °C is permissible. Continuous operation below -25 °C only with special bearings for refrigeration applications on request.

Characteristic curve

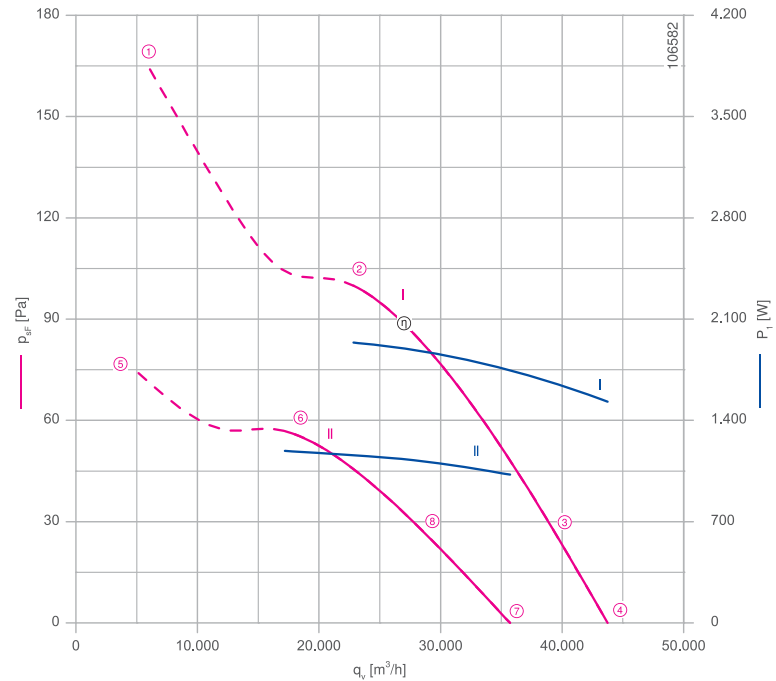

Measured in full bell mouth without guard grille in installation type A according to ISO 5801.

Connection diagram Page 174
1360-108XB

System components Page 110

Dimensions mm

Airflow direction A

Design T - for installation in chimney exhausts, without guard grille

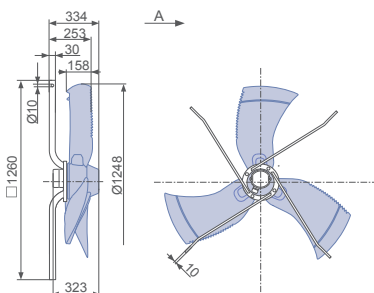

Design L - round full bell mouth, without guard grille

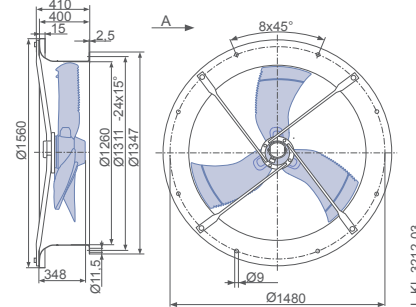

Wall ring plate made of galvanized sheet steel

Design L - round full bell mouth, guard grille suction side

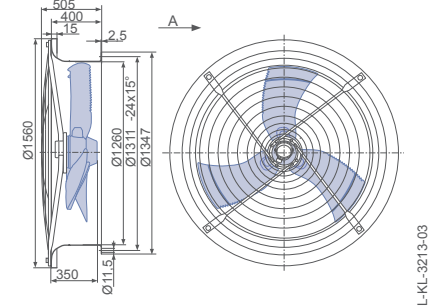

Wall ring plate made of galvanized sheet steel



Performance data

Type	Characteristic curve	Connection	Voltage	Operating point	Current	Input power	Speed	Acoustic pressure level 7m	Specific power	
			U V		I A	P ₁ W	n min ⁻¹	L _{pA} dB(A)	P _{spez} Wh/1000m ³	
FN125-MD_7Q_3P1	I	Δ	400	①	5.40	2500	500			
				②	4.60	1950	530		85.2	
				③	4.20	1550	550	49	35.0	
				④	4.20	1700	540	48	43.1	
	II	Y	400	⑤	2.70	1300	340			
				⑥	2.40	1200	400		69.3	
				⑦	2.10	1000	450		43	28.7
				⑧	2.30	1150	420		41	40.6

Fan ordering information

Airflow direction A →

Design	T (without guard grille)	L (without guard grille)	L (guard grille suction side)
			
Type	FN125-MDT.7Q.A3P1	FN125-MDL.7Q.A3P1	FN125-MDL.7Q.A3P1
Article no.	168046	168047	168048
Wall ring plate		Wall ring plate made of galvanized sheet steel	Wall ring plate made of galvanized sheet steel
Weight kg	54.70	101.00	108.60

Control technology

Frequency inverters Fcontrol 3~	Motor protection units 3~	Electronic voltage controllers 3~
		
Page 144	Page 154	Page 150

FC

For single and three-phase AC current



Description

Motor technology: AC
 Thermal class: THCL155
 Min. authorised media temperature $t_{R(min)}$: 3~ -40 °C***, or 1~ -25 °C
 Min. authorised media temperature $t_{R(min)}$: -10 °C (wall ring plate made of composite material)
 Max. authorised media temperature $t_{R(max)}$: 40 °C
 Wall ring plate material: * galvanised steel sheet, ** composite material
 Electrical connection: Terminal box
 Protection class: IP54
 Motor protection: Thermostat
 Blades: Aluminium, 1-layer coating, black
 Rotor: Aluminium, 1-layer coating, black
 *** Continuous operation with occasional starts (S1) according to DIN EN 60034-1:2011-02. Occasional starting between -40 °C and -25 °C is permissible. Continuous operation below -25 °C only with special bearings for refrigeration applications on request.

Performance data

Low-pressure fans											
Type	Rating plate information						Values at operating point				Connection diagram
	P_1 W	U +/- 10% V	$I_{meas.}$ A	I_{max} A	n min ⁻¹	C μF	$p_{sF}=0$ Pa		$p_{sF}=30$ Pa		
							q_v m ³ /h	q_v m ³ /h	P_{spec} Wh/1000m ³	L_{pA} dB (A)	
FC035-4E_2C.A7	160	1~230	0,75	0,96	1370	8	3460	3050	51,5	46	123XB
FC040-4E_4C.A7	260	1~230	1,20	1,55	1370	6	4730	4400	53,5	49	104XB
FC045-4E_4F.A7	380	1~230	1,90	2,25	1365	7	6350	5950	56,5	54	104XB
FC045-4D_4C.A7	360	3~400	0,75	0,75	1390	-	6400	5950	53,8	53	106XB
FC050-4E_4I.A7	510	1~230	2,30	2,7	1310	8	8000	7400	59,7	53	104XB
FC050-4D_4F.A7	530	3~400	1,10	1,2	1360	-	8330	7800	59,0	54	106XB

Sound pressure level taking into account the protective guard, free blowing at a distance of 7m on the output side, 45° to the axis of the fan.

Airflow direction A

Design T - for installation in chimney exhausts, without guard grille
FC040-050

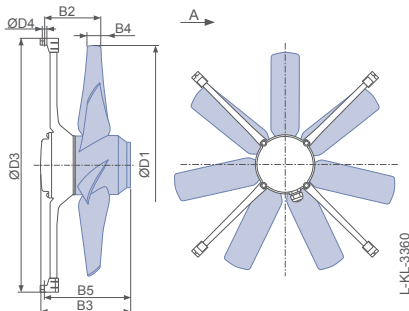

Design Q - square full bell mouth, without guard grille
FC040-050

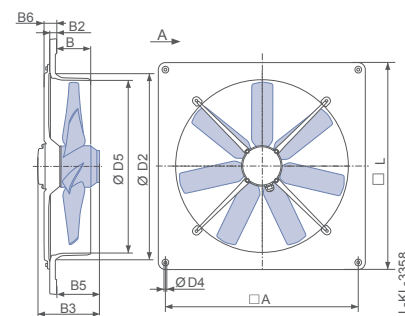

Design Q - square full bell mouth, guard grille suction side
FC035

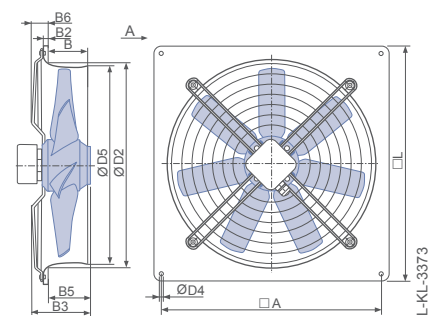

Fans design T without guard grille

Type	Article no.	B2 mm	B3 mm	B4 mm	B5 mm	D1 mm	D3 mm	D4 mm	Weight kg
FC040-4ET.4C.A7	141138	148	183	37	173	395	400	9	6,9
FC045-4ET.4F.A7	130773	147	198	33	189	447	457	9	8,4
FC045-4DT.4C.A7	130789	147	183	33	174	447	457	9	7,0
FC050-4ET.4I.A7	130775	148	218	37	209	497	506	9	10,5
FC050-4DT.4F.A7	130791	148	198	37	189	497	506	9	8,8

Fans design Q without guard grille

Type	Article no.	A mm	B mm	B2 mm	B3 mm	B5 mm	B6 mm	D2 mm	D4 mm	D5 mm	L mm	Weight kg
FC040-4EQ.4C.A7	141070**	490	127	23	182	98	61	461	9	411	540	9,4
FC045-4EQ.4F.A7	141071**	535	125	25	198	112	63	510	10	466	575	11,2
FC045-4DQ.4C.A7	141181**	535	125	25	183	97	63	510	10	466	575	9,8
FC050-4EQ.4I.A7	141072**	615	135	25	218	132	63	560	11	516	655	14,0
FC050-4DQ.4F.A7	141182**	615	135	25	198	112	63	560	11	516	655	12,3

Fans design Q with guard grille

Type	Article no.	A mm	B mm	B2 mm	B3 mm	B5 mm	B6 mm	D2 mm	D4 mm	D5 mm	L mm	Weight kg
FC035-4EQ.2C.A7	141212*	435	75	12	177	89	50	372	9	367	485	7,5
FC040-4EQ.4C.A7	141073**	490	127	23	183	99	67	461	9	411	540	10,4
FC045-4EQ.4F.A7	141178**	535	125	25	198	113	69	510	10	452	575	12,2
FC045-4DQ.4C.A7	141177**	535	125	25	183	97	69	510	10	452	575	10,9
FC050-4EQ.4I.A7	141183**	615	135	25	218	132	74	560	11	516	655	16,7
FC050-4DQ.4F.A7	141184**	615	135	25	197	112	74	560	11	516	655	13,5

Design Q - square full bell mouth, guard grille suction side

FC040-050

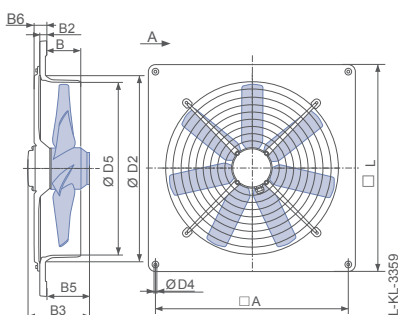



High pressure fans

Product overview

Fans overview	Page 82
FE2owlet-ECblue	
Size 630	Page 84
Size 710	Page 86
Size 800	Page 88
Size 910	Page 92
FE2owlet-ECblue with ZAplus	
Size 630	Page 96
Size 710	Page 98
Size 800	Page 100
Size 910	Page 104
FC	
Size 630 to 910	Page 108

Information

Low pressure

High pressure

System components

Control technology

Appendix

Fans overview

EC technology

Product overview

Type	Rating plate information				Values at operating point				Acoustic pressure level 7m	
	P ₁ kW	U V	I A	n min-1	p=0 Pa		p=100 Pa			
					q _v m ³ /h	q _v m ³ /h	P _{spez} Wh/1000m ³	L _{pA} dB(A)		
FN063-ZI_GL.A7P3	3,60	3~ 380-480	5,80-4,60	1.600	21.730	20.365	159,2	61	Page 84	
FN071-ZI_GL.A7P4	4,60	3~ 380-480	7,20-5,80	1.530	26.647	24.744	148,7	60	Page 86	
FN080-ZI_GL.A7P3	3,60	3~ 380-480	5,80-4,60	1.180	29.784	26.616	109,9	55	Page 88	
FN080-ZI_GQ.A7P3	4,20	3~ 380-480	6,60-5,20	1.250	31.640	28.898	117,7	58	Page 90	
FN091-ZI_GL.A5P1	3,50	3~ 380-480	5,60-4,40	1.130	33.440	29.523	90,6	58	Page 92	
FN091-ZI_GQ.A5P1	5,00	3~ 380-480	8,00-6,40	1.280	38.139	34.850	106,6	62	Page 94	
ZN063-ZI_GL.V7P3	3,70	3~ 380-480	6,00-4,70	1.600	22.890	21.641	143,4	64	Page 96	
ZN071-ZI_GL.V7P4	4,20	3~ 380-480	6,80-5,40	1.530	27.471	25.863	133,7	64	Page 98	
ZN080-ZI_GL.V7P3	3,50	3~ 380-480	5,60-4,40	1.180	30.260	27.618	104,2	57	Page 100	
ZN080-ZI_GQ.V7P3	4,00	3~ 380-480	6,60-5,20	1.250	31.966	29.523	113,7	60	Page 102	
ZN091-ZI_GL.V5P1	3,40	3~ 380-480	5,40-4,20	1.130	33.994	30.827	80,0	60	Page 104	
ZN091-ZI_GQ.V5P1	3,90	3~ 380-480	6,20-5,00	1.180	35.941	32.759	85,9	62	Page 106	



Information

Low pressure

High pressure

System
components

Control
technology

Appendix



FE2owlet-ECblue

for three phase alternating current, 380-480 V

FN063



Description

Motor technology: EC
 Rated voltage U_N : 3- 380-480 V*
 Rated frequency f_N : 50/60 Hz*
 Input power P_{sys} : 3.60 kW*
 Rated current I_N : 5.80- 4.60 A*
 Rated speed n_N : 1600 min⁻¹*
 Thermal class: THCL155*
 Min. permitted ambient temperature $t_{R(min)}$: -35 °C ***
 Max. permitted ambient temperature $t_{R(max)}$: 55 °C
 Electrical connection: Integrated controller
 Number of blades: 7
 Degree of protection : IP55
 Motor protection: Integrated active temperature management
 Blades: Aluminium, powder-coated, ultramarine blue
 Rotor: Aluminium, 2 coat paint, ultramarine blue
 Conformity: ErP 2015, CE, UL

ErP-data

Efficiency η_{statA} : 43.0 %
 Efficiency: $N_{actual} = 45.8 / N_{target} = 40^{**}$
 EC controller integrated

* Rated data

**ErP 2015

*** Continuous operation with occasional starts (S1) according to DIN EN 60034-1:2011-02. Occasional starting between -35 °C and -25 °C is permissible. Continuous operation below -25 °C only with special bearings for refrigeration applications on request.

Characteristic curve

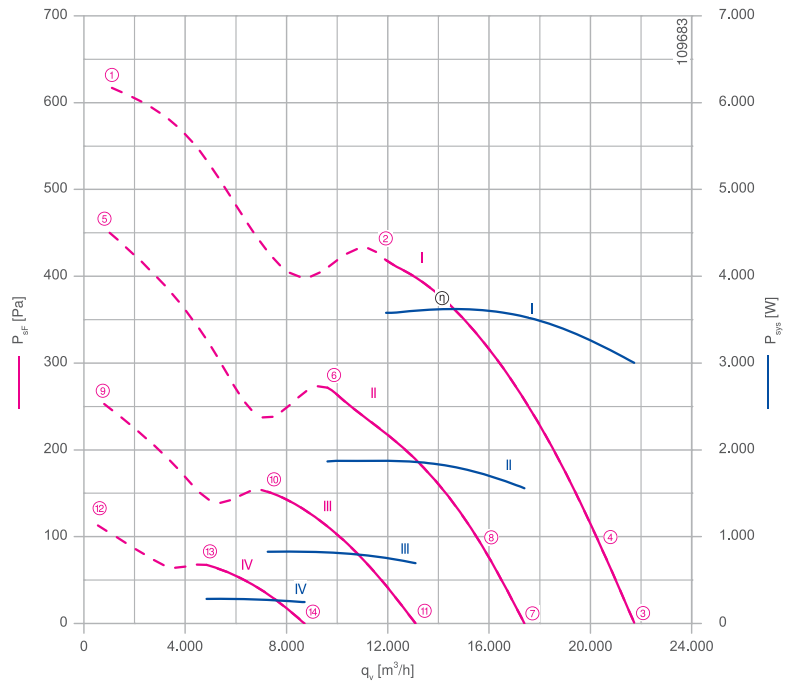

Measured in full bell mouth without guard grille in installation type A according to ISO 5801.

Connection diagram Page 172
1360-403

System components Page 110

Dimensions mm

Airflow direction A

Design T - for installation in chimney exhausts, without guard grille

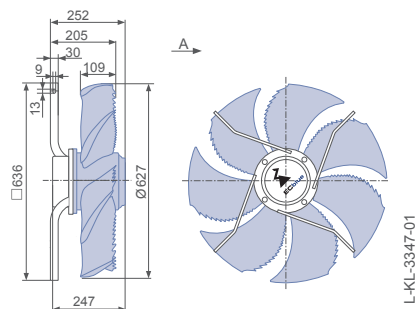

Design Q - square full bell mouth, without guard grille

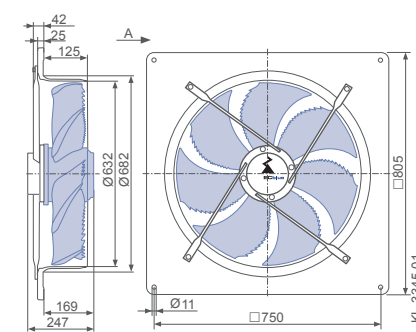

Wall ring plate made of composite material

Design Q - square full bell mouth, guard grille suction side

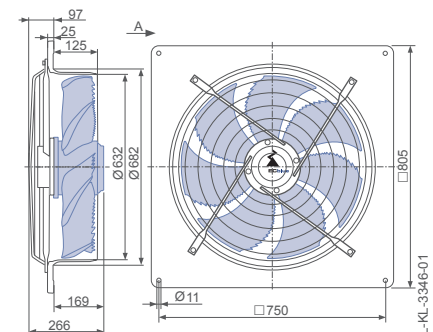

Wall ring plate made of composite material



Performance data

Type	Characteristic curve	Speed n min ⁻¹	Operating point	Current	Input power	Acoustic pressure level 7m	Specific power
				I A	P _{sys} W	L _{pA} dB(A)	P _{spez} Wh/1000m³
FN063-ZL_GL_7P3	I	1600	①	5.80	3800		
			②	5.40	3600		300.3
			③	4.60	3000	62	138.1
			④	5.00	3200	61	159.2
	II	1280	⑤	3.60	2300		
			⑥	2.90	1850		194.6
			⑦	2.40	1550	57	89.6
			⑧	2.70	1750	55	112.0
	III	960	⑨	1.65	1000		
			⑩	1.40	820		114.9
			⑪	1.20	700	50	53.1
	IV	640	⑫	0.74	340		
			⑬	0.64	280		59.2
			⑭	0.58	250	42	28.2

Current values determined at 400V

Fan ordering information

Airflow direction A

Design	T (without guard grille)	Q (without guard grille)	Q (guard grille suction side)	Q (without guard grille)	Q (guard grille suction side)
Type	FN063-ZIT.GL.A7P3	FN063-ZIQ.GL.A7P3	FN063-ZIQ.GL.A7P3	FN063-ZIQ.GL.A7P3	FN063-ZIQ.GL.A7P3
Article no.	168000	168003	168004	168001	168002
Wall ring plate		composite material	composite material	galvanized sheet steel	galvanized sheet steel
Weight kg	31.60	36.40	38.80	41.90	44.20
Supply temperature -10°C - max 40°C in design with wall ring plate made of composite material					

Control technology

Control module UNIcon Zenec switch

Page 130

Page 158

Design Q - square full bell mouth, without guard grille

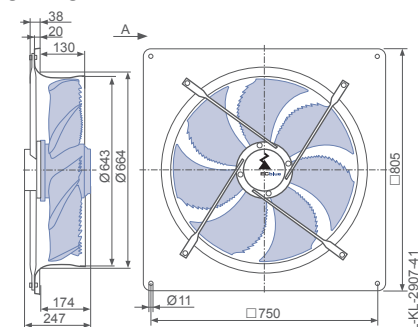

Wall ring plate made of galvanized sheet steel

Design Q - square full bell mouth, guard grille suction side

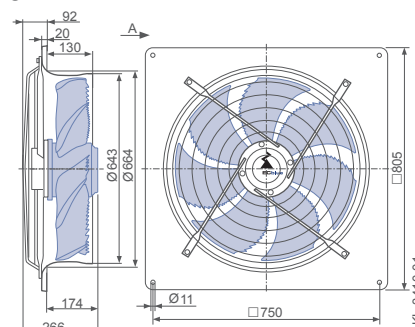

Wall ring plate made of galvanized sheet steel

FE2owlet-ECblue

for three phase alternating current, 380-480 V

FNO71



Description

Motor technology: EC
 Rated voltage U_N : 3- 380-480 V*
 Rated frequency f_N : 50/60 Hz*
 Input power P_{sys} : 4.60 kW*
 Rated current I_N : 7.20- 5.80 A*
 Rated speed n_N : 1530 min⁻¹*
 Thermal class: THCL155*
 Min. permitted ambient temperature $t_{R(min)}$: -35 °C ***
 Max. permitted ambient temperature $t_{R(max)}$: 40 °C
 Electrical connection: Integrated controller
 Number of blades: 7
 Degree of protection : IP55
 Motor protection: Integrated active temperature management
 Blades: Aluminium, powder-coated, ultramarine blue
 Rotor: Aluminium, 2 coat paint, ultramarine blue
 Conformity: ErP 2015, CE, UL

ErP-data

Efficiency η_{statA} : 44.1 %
 Efficiency: $N_{actual} = 46.5 / N_{target} = 40^{**}$
 EC controller integrated

* Rated data

**ErP 2015

*** Continuous operation with occasional starts (S1) according to DIN EN 60034-1:2011-02. Occasional starting between -35 °C and -25 °C is permissible. Continuous operation below -25 °C only with special bearings for refrigeration applications on request.

Characteristic curve

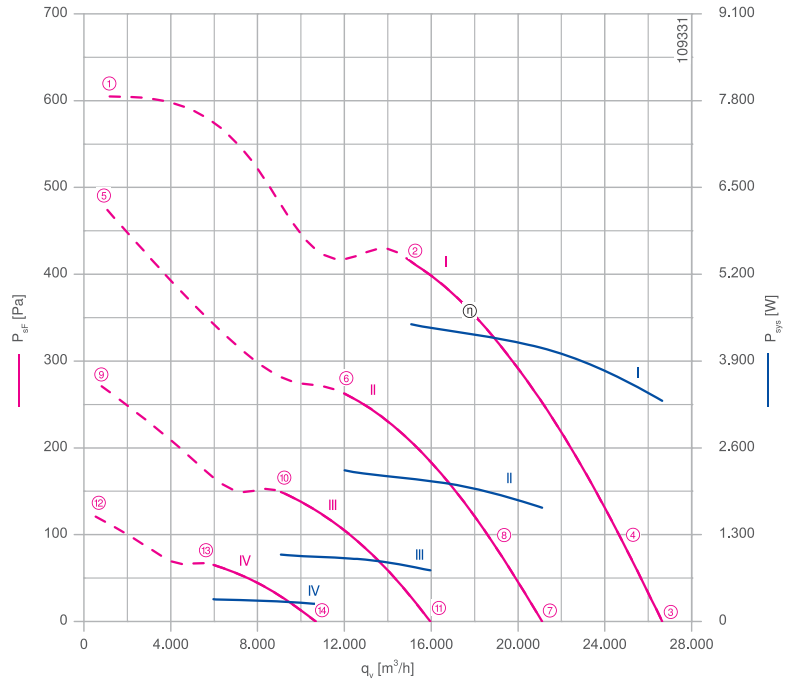

Measured in full bell mouth without guard grille in installation type A according to ISO 5801.

Connection diagram Page 172
1360-403

System components Page 110

Dimensions mm

Airflow direction A

Design T - for installation in chimney exhausts, without guard grille

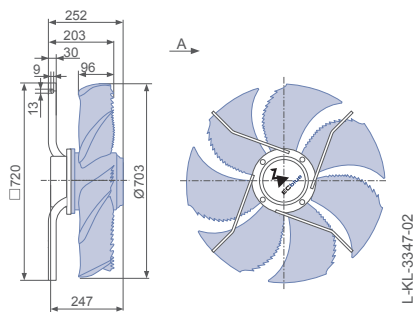

Design Q - square full bell mouth, without guard grille

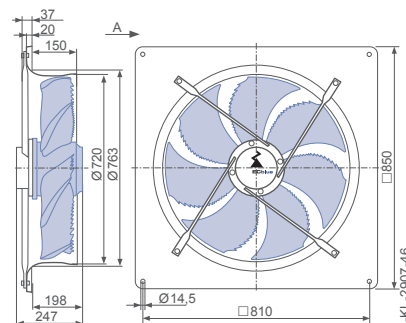

Wall ring plate made of galvanized sheet steel

Design Q - square full bell mouth, guard grille suction side

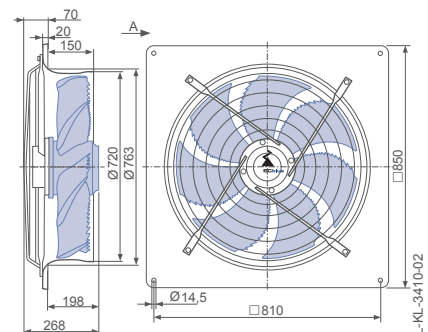

Wall ring plate made of galvanized sheet steel



Performance data

Type	Characteristic curve	Speed n min ⁻¹	Operating point	Current	Input power	Acoustic pressure level 7m	Specific power
				I A	P _{sys} W	L _{pA} dB(A)	P _{spez} Wh/1000m ³
FN071-ZL_GL_7P4	I	1530	①	7.00	4600		
			②	6.80	4400		295.8
			③	5.00	3300	61	124.1
			④	5.60	3700	60	148.7
	II	1220	⑤	4.80	3200		
			⑥	3.50	2300		188.9
			⑦	2.60	1700	55	80.7
			⑧	3.10	2000	54	105.5
	III	920	⑨	2.20	1400		
			⑩	1.65	1000		110.9
			⑪	1.30	760	47	47.9
			⑫	0.92	440		
	IV	610	⑬	0.76	330		
			⑭	0.66	260	38	24.8

Current values determined at 400V

Fan ordering information

Airflow direction A			
Design	T (without guard grille)	Q (without guard grille)	Q (guard grille suction side)
			
Type	FN071-ZIT.GL.A7P4	FN071-ZIQ.GL.A7P4	FN071-ZIQ.GL.A7P4
Article no.	168007	168008	168009
Wall ring plate		Wall ring plate made of galvanized sheet steel	Wall ring plate made of galvanized sheet steel
Weight kg	30.70	41.70	45.20

Control technology

Control module UNIcon Zenec switch



Page 130



Page 158

FE2owlet-ECblue

for three phase alternating current, 380-480 V

FN080



Description

Motor technology: EC
 Rated voltage U_N : 3- 380-480 V*
 Rated frequency f_N : 50/60 Hz*
 Input power P_{sys} : 3.60 kW*
 Rated current I_N : 5.80- 4.60 A*
 Rated speed n_N : 1180 min⁻¹*
 Thermal class: THCL155*
 Min. permitted ambient temperature $t_{R(min)}$: -35 °C ***
 Max. permitted ambient temperature $t_{R(max)}$: 40 °C
 Electrical connection: Integrated controller
 Number of blades: 7
 Degree of protection : IP55
 Motor protection: Integrated active temperature management
 Blades: Aluminium, powder-coated, ultramarine blue
 Rotor: Aluminium, 2 coat paint, ultramarine blue
 Conformity: ErP 2015, CE, UL

ErP-data

Efficiency η_{statA} : 47.5 %
 Efficiency: $N_{actual} = 50.5 / N_{target} = 40^{**}$
 EC controller integrated

* Rated data

**ErP 2015

*** Continuous operation with occasional starts (S1) according to DIN EN 60034-1:2011-02. Occasional starting between -35 °C and -25 °C is permissible. Continuous operation below -25 °C only with special bearings for refrigeration applications on request.

Characteristic curve

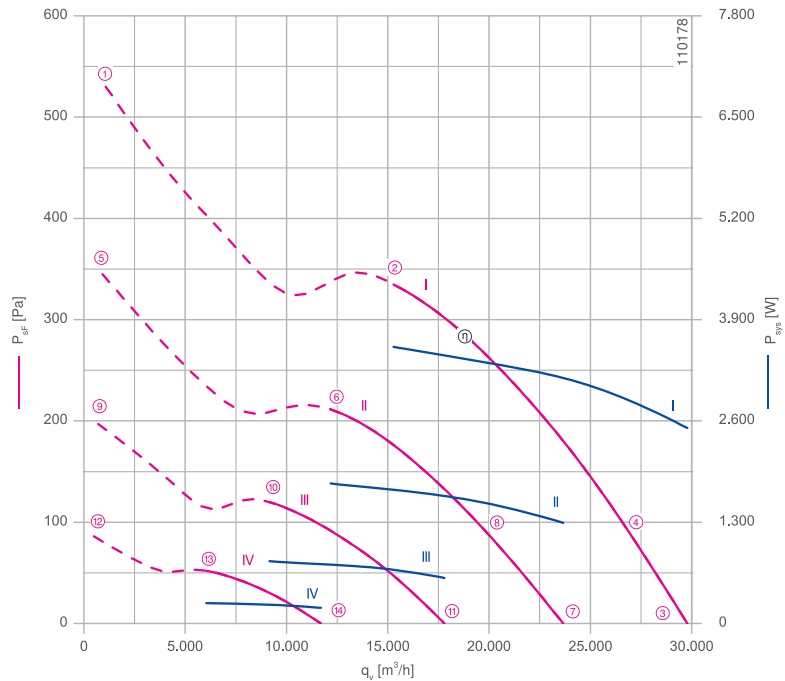

Measured in full bell mouth without guard grille in installation type A according to ISO 5801.

Connection diagram Page 172
1360-403

System components Page 110

Dimensions mm

Airflow direction A

Design T - for installation in chimney exhausts, without guard grille

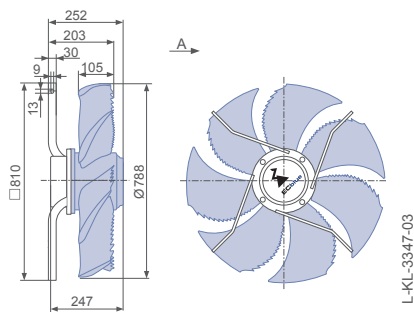

Design Q - square full bell mouth, without guard grille

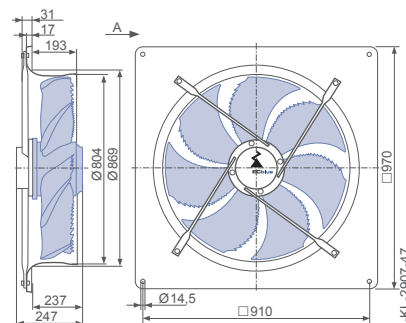

Wall ring plate made of galvanized sheet steel

Design Q - square full bell mouth, guard grille suction side

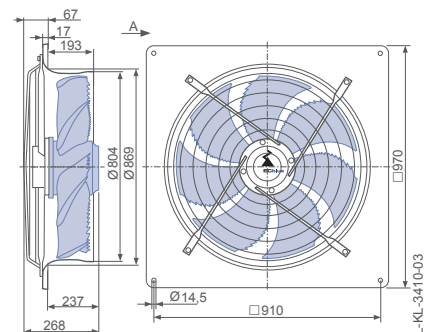

Wall ring plate made of galvanized sheet steel



Performance data

Type	Characteristic curve	Speed n min ⁻¹	Operating point	Current	Input power	Acoustic pressure level 7m	Specific power
				I A	P _{sys} W	L _{pA} dB(A)	P _{spez} Wh/1000m ³
FN080-ZL_GL_7P3	I	1180	①	7.40	4800		
			②	5.40	3600		234.3
			③	3.90	2500	56	84.3
			④	4.40	2900	55	109.9
	II	940	⑤	3.80	2500		
			⑥	2.80	1800		149.0
			⑦	2.10	1300	51	54.6
			⑧	2.50	1600	48	81.3
	III	710	⑨	1.75	1100		
			⑩	1.35	800		87.9
			⑪	1.05	580	45	32.8
	IV	470	⑫	0.76	340		
			⑬	0.64	260		43.8
			⑭	0.54	200	37	17.2

Current values determined at 400V

Fan ordering information

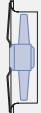
Airflow direction A			
Design	T (without guard grille)	Q (without guard grille)	Q (guard grille suction side)
			
Type	FN080-ZIT.GL.A7P3	FN080-ZIQ.GL.A7P3	FN080-ZIQ.GL.A7P3
Article no.	168012	168013	168014
Wall ring plate		Wall ring plate made of galvanized sheet steel	Wall ring plate made of galvanized sheet steel
Weight kg	34.80	49.60	53.40

Control technology

Control module UNIcon Zenec switch



Page 130



Page 158

FE2owlet-ECblue

for three phase alternating current, 380-480 V

FN080



Description

Motor technology: EC
 Rated voltage U_N : 3- 380-480 V*
 Rated frequency f_N : 50/60 Hz*
 Input power P_{sys} : 4.20 kW*
 Rated current I_N : 6.60- 5.20 A*
 Rated speed n_N : 1250 min⁻¹*
 Thermal class: THCL155*
 Min. permitted ambient temperature $t_{R(min)}$: -35 °C ***
 Max. permitted ambient temperature $t_{R(max)}$: 50 °C
 Electrical connection: Integrated controller
 Number of blades: 7
 Degree of protection : IP55
 Motor protection: Integrated active temperature management
 Blades: Aluminium, powder-coated, ultramarine blue
 Rotor: Aluminium, 2 coat paint, ultramarine blue
 Conformity: ErP 2015, CE, UL

ErP-data

Efficiency η_{statA} : 48.8 %
 Efficiency: $N_{actual} = 51.4 / N_{target} = 40^{**}$
 EC controller integrated

* Rated data

**ErP 2015

*** Continuous operation with occasional starts (S1) according to DIN EN 60034-1:2011-02. Occasional starting between -35 °C and -25 °C is permissible. Continuous operation below -25 °C only with special bearings for refrigeration applications on request.

Characteristic curve

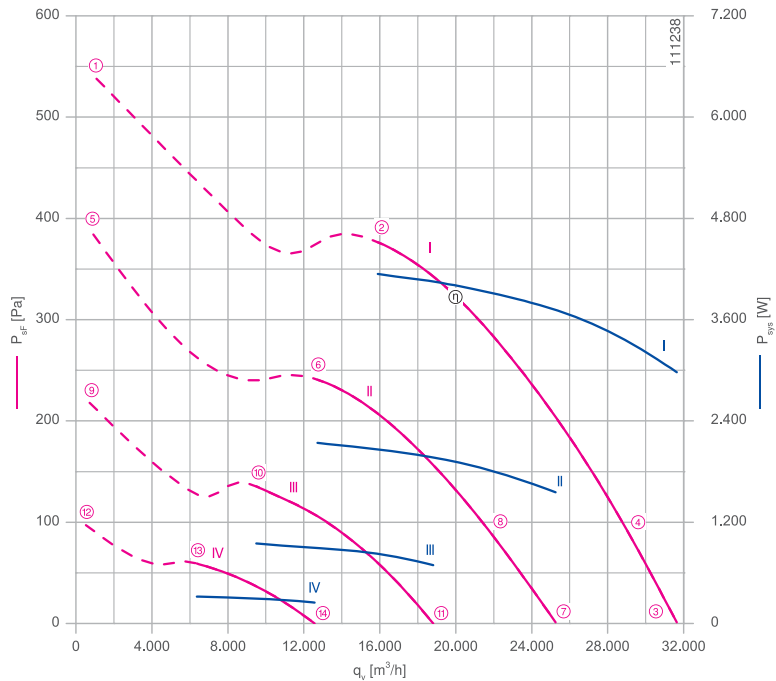

Measured in full bell mouth without guard grille in installation type A according to ISO 5801.

Connection diagram Page 172
1360-403

System components Page 110

Dimensions mm

Airflow direction A

Design T - for installation in chimney exhausts, without guard grille

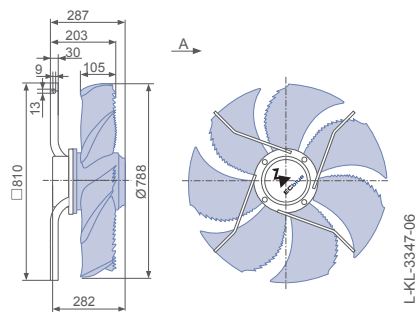

Design Q - square full bell mouth, without guard grille

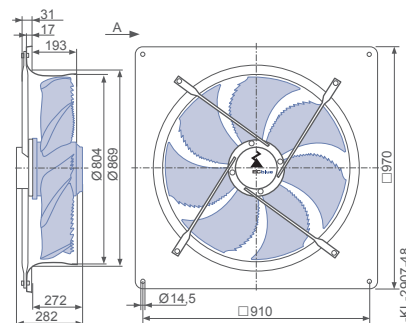

Wall ring plate made of galvanized sheet steel

Design Q - square full bell mouth, guard grille suction side

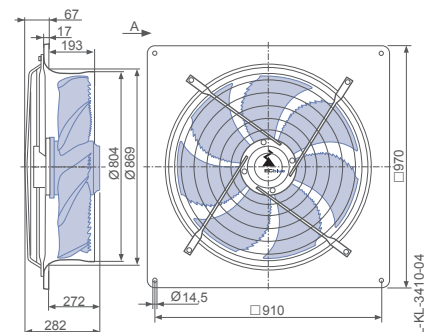

Wall ring plate made of galvanized sheet steel





Performance data

Type	Characteristic curve	Speed n min ⁻¹	Operating point	Current	Input power	Acoustic pressure level 7m	Specific power
				I A	P _{sys} W	L _{pA} dB(A)	P _{spez} Wh/1000m ³
FN080-ZI_GQ_7P3	I	1250	①	7.40	4800		
			②	6.40	4200		261.9
			③	4.60	3000	59	94.1
			④	5.20	3400	58	117.7
	II	1000	⑤	4.60	2900		
			⑥	3.30	2100		168.8
			⑦	2.50	1550	53	61.6
			⑧	2.90	1850	51	86.3
	III	750	⑨	2.00	1250		
			⑩	1.55	940		100.0
			⑪	1.20	700	46	36.7
	IV	500	⑫	0.84	420		
			⑬	0.70	320		50.6
			⑭	0.60	250	39	19.7

Current values determined at 400V

Fan ordering information

Airflow direction A 

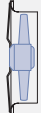
Design	T (without guard grille)	Q (without guard grille)	Q (guard grille suction side)
			
Type	FN080-ZIT.GQ.A7P3	FN080-ZIQ.GQ.A7P3	FN080-ZIQ.GQ.A7P3
Article no.	168017	168018	168019
Wall ring plate		Wall ring plate made of galvanized sheet steel	Wall ring plate made of galvanized sheet steel
Weight kg	40.90	56.40	60.20

Control technology

Control module UNIcon Zenec switch



Page 130



Page 158

FE2owlet-ECblue

for three phase alternating current, 380-480 V

FN091



Description

Motor technology: EC
 Rated voltage U_N : 3- 380-480 V*
 Rated frequency f_N : 50/60 Hz*
 Input power P_{sys} : 3.50 kW*
 Rated current I_N : 5.60- 4.40 A*
 Rated speed n_N : 1130 min⁻¹*
 Thermal class: **THCL155***
 Min. permitted ambient temperature $t_{R(min)}$: -35 °C ***
 Max. permitted ambient temperature $t_{R(max)}$: 40 °C
 Electrical connection: Integrated controller
 Number of blades: 5
 Degree of protection : IP55
 Motor protection: Integrated active temperature management
 Blades: Aluminium, powder-coated, ultramarine blue
 Rotor: Aluminium, 2 coat paint, ultramarine blue
 Conformity: ErP 2015, CE, UL

ErP-data

Efficiency η_{statA} : 52.4 %
 Efficiency: $N_{actual} = 55.5 / N_{target} = 40^{**}$
 EC controller integrated

* Rated data

**ErP 2015

*** Continuous operation with occasional starts (S1) according to DIN EN 60034-1:2011-02. Occasional starting between -35 °C and -25 °C is permissible. Continuous operation below -25 °C only with special bearings for refrigeration applications on request.

Characteristic curve

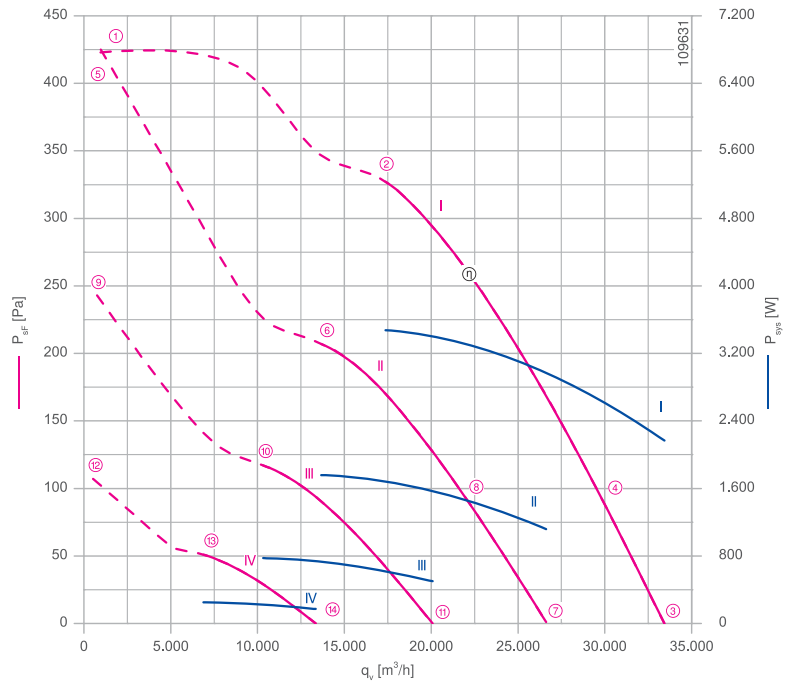

Measured in full bell mouth without guard grille in installation type A according to ISO 5801.

Connection diagram Page 172
1360-403

System components Page 110

Dimensions mm

Airflow direction A

Design T - for installation in chimney exhausts, without guard grille

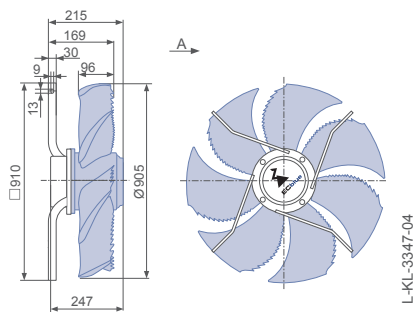

Design Q - square full bell mouth, without guard grille

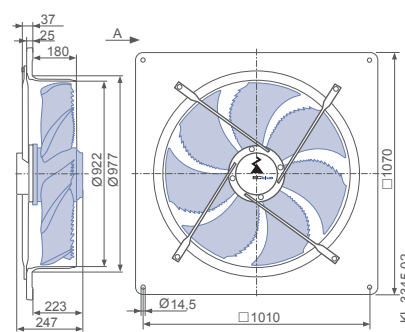

Wall ring plate made of composite material

Design Q - square full bell mouth, guard grille suction side

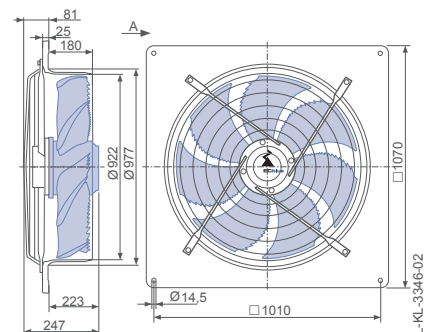

Wall ring plate made of composite material



Performance data

Type	Characteristic curve	Speed n min ⁻¹	Operating point	Current	Input power	Acoustic pressure level 7m	Specific power
				I A	P _{sys} W	L _{pA} dB(A)	P _{spez} Wh/1000m ³
FN091-ZL_GL_5P1	I	1130	①	4.80	3100		
			②	5.20	3500		202.9
			③	3.30	2200	59	64.8
			④	4.00	2700	58	90.6
	II	900	⑤	4.80	3100		
			⑥	2.70	1750		129.3
			⑦	1.80	1100	53	42.0
			⑧	2.30	1500	53	69.1
	III	680	⑨	2.10	1350		
			⑩	1.30	780		75.7
			⑪	0.94	500	45	24.9
			⑫	0.84	420		
	IV	450	⑬	0.60	250		
			⑭	0.46	170	36	12.9

Current values determined at 400V

Fan ordering information

Airflow direction A					
Design	T (without guard grille)	Q (without guard grille)	Q (guard grille suction side)	Q (without guard grille)	Q (guard grille suction side)
Type	FN091-ZIT.GL.A5P1	FN091-ZIQ.GL.A5P1	FN091-ZIQ.GL.A5P1	FN091-ZIQ.GL.A5P1	FN091-ZIQ.GL.A5P1
Article no.	168022	168025	168026	168023	168024
Wall ring plate		composite material	composite material	galvanized sheet steel	galvanized sheet steel
Weight kg	33.20	43.60	48.20	51.00	55.60
Supply temperature	-10°C - max 40°C in design with wall ring plate made of composite material				

Control technology

Control module UNIcon Zenec switch

Page 130

Page 158

Design Q - square full bell mouth, without guard grille

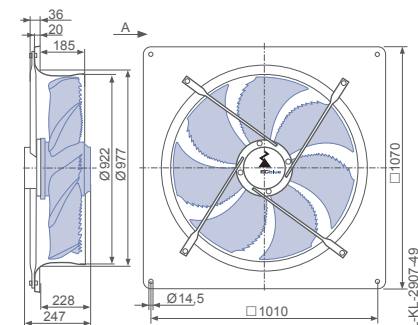

Wall ring plate made of galvanized sheet steel

Design Q - square full bell mouth, guard grille suction side

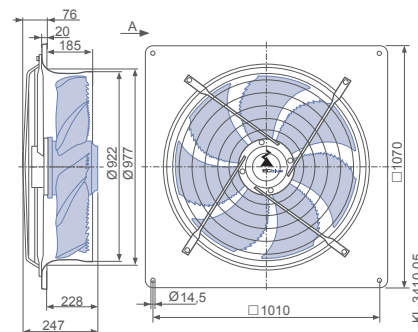

Wall ring plate made of galvanized sheet steel

FE2owlet-ECblue

for three phase alternating current, 380-480 V

FN091



Description

Motor technology: EC
 Rated voltage U_N : 3- 380-480 V*
 Rated frequency f_N : 50/60 Hz*
 Input power P_{sys} : 5.00 kW*
 Rated current I_N : 8.00- 6.40 A*
 Rated speed n_N : 1280 min⁻¹*
 Thermal class: **THCL155***
 Min. permitted ambient temperature $t_{R(min)}$: -35 °C ***
 Max. permitted ambient temperature $t_{R(max)}$: 40 °C
 Electrical connection: Integrated controller
 Number of blades: 5
 Degree of protection : IP55
 Motor protection: Integrated active temperature management
 Blades: Aluminium, powder-coated, ultramarine blue
 Rotor: Aluminium, 2 coat paint, ultramarine blue
 Conformity: ErP 2015, CE, UL

ErP-data

Efficiency η_{statA} : 53.3 %
 Efficiency: $N_{actual} = 55.4 / N_{target} = 40^{**}$
 EC controller integrated

* Rated data

**ErP 2015

*** Continuous operation with occasional starts (S1) according to DIN EN 60034-1:2011-02. Occasional starting between -35 °C and -25 °C is permissible. Continuous operation below -25 °C only with special bearings for refrigeration applications on request.

Characteristic curve

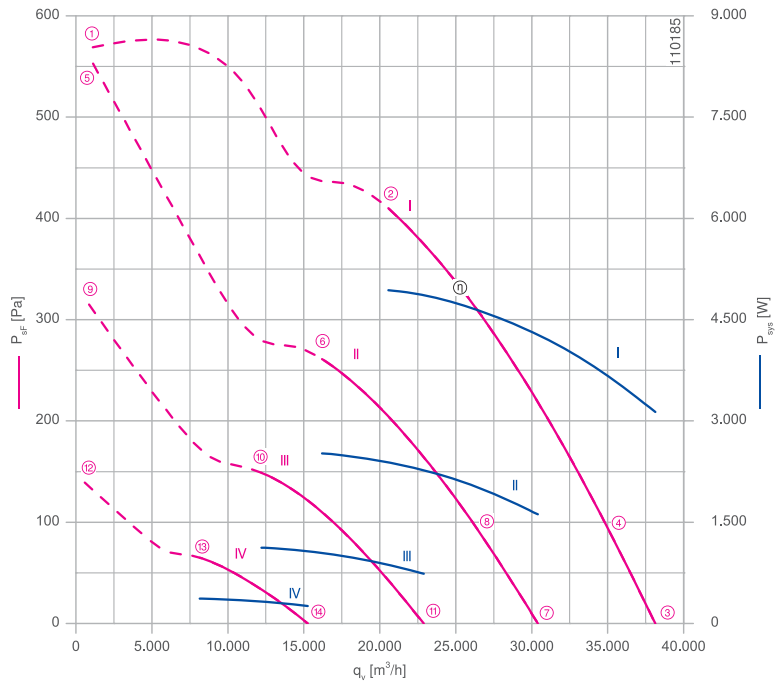

Measured in full bell mouth without guard grille in installation type A according to ISO 5801.

Connection diagram Page 172
1360-403

System components Page 110

Dimensions mm

Airflow direction A

Design T - for installation in chimney exhausts, without guard grille

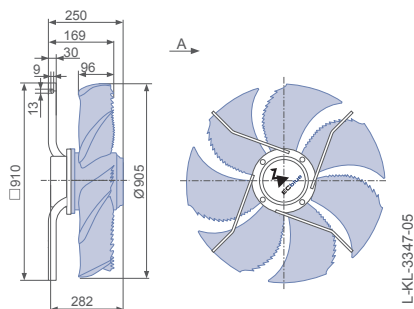

Design Q - square full bell mouth, without guard grille

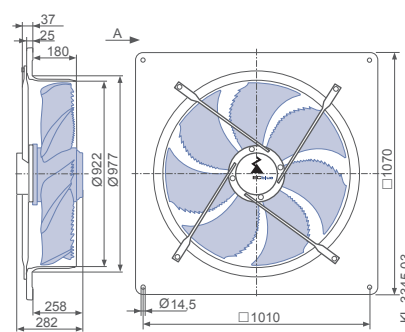

Wall ring plate made of composite material

Design Q - square full bell mouth, guard grille suction side

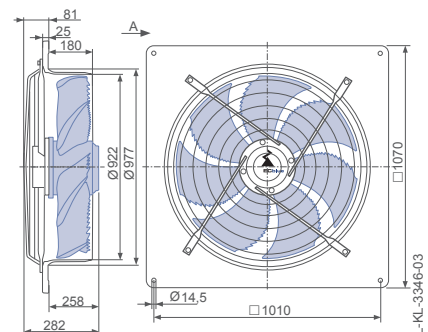

Wall ring plate made of composite material







Performance data

Type	Characteristic curve	Speed n min ⁻¹	Operating point	Current	Input power	Acoustic pressure level 7m	Specific power
				I A	P _{sys} W	L _{pA} dB(A)	P _{spez} Wh/1000m³
FN091-ZL_GQ_5P1	I	1280	①	7.20	4800		
			②	7.40	5000		243.2
			③	4.80	3100	63	82.1
			④	5.60	3700	62	106.6
	II	1020	⑤	6.80	4600		
			⑥	3.80	2500		156.0
			⑦	2.50	1600	56	53.2
			⑧	3.20	2100	56	78.5
	III	770	⑨	3.00	1950		
			⑩	1.80	1100		92.0
			⑪	1.30	740	48	32.1
			⑫	1.10	600		
	IV	510	⑬	0.80	370		
			⑭	0.64	260	40	16.9

Current values determined at 400V

Fan ordering information

Airflow direction A					
Design	T (without guard grille)	Q (without guard grille)	Q (guard grille suction side)	Q (without guard grille)	Q (guard grille suction side)
					
Type	FN091-ZIT.GQ.A5P1	FN091-ZIQ.GQ.A5P1	FN091-ZIQ.GQ.A5P1	FN091-ZIQ.GQ.A5P1	FN091-ZIQ.GQ.A5P1
Article no.	168029	168032	168033	168030	168031
Wall ring plate		composite material	composite material	galvanized sheet steel	galvanized sheet steel
Weight kg	40.00	57.80	55.00	57.80	62.40
Supply temperature -10°C - max 40°C in design with wall ring plate made of composite material					

Control technology

Control module UNIcon Zenec switch



Page 130



Page 158

Design Q - square full bell mouth, without guard grille

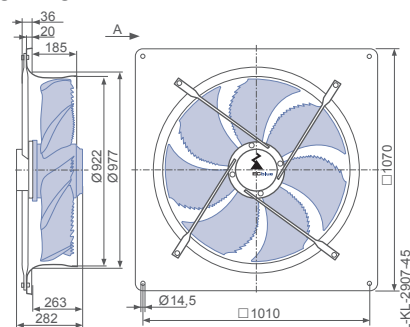

Wall ring plate made of galvanized sheet steel

Design Q - square full bell mouth, guard grille suction side

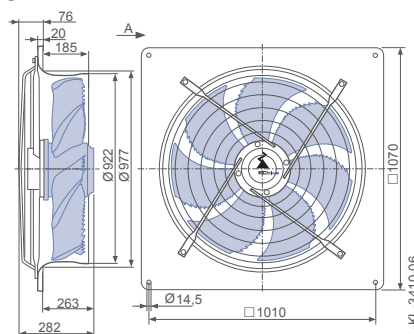

Wall ring plate made of galvanized sheet steel

FE2owlet-ECblue with ZPlus

for three phase alternating current, 380-480 V

ZN063



Description

Motor technology: EC
 Rated voltage U_N : 3~ 380-480 V*
 Rated frequency f_N : 50/60 Hz*
 Input power P_{sys} : 3.70 kW*
 Rated current I_N : 6.00- 4.70 A*
 Rated speed n_N : 1600 min⁻¹*
 Thermal class: THCL155*
 Min. permitted ambient temperature $t_{R(min)}$: -35 °C ***
 Max. permitted ambient temperature $t_{R(max)}$: 55 °C
 Electrical connection: Integrated controller
 Number of blades: 7
 Degree of protection : IP55
 Motor protection: Integrated active temperature management
 Blades: Aluminium, powder-coated, ultramarine blue
 Rotor: Aluminium, 2 coat paint, ultramarine blue
 Conformity: ErP 2015, CE, UL

ErP-data

Efficiency η_{statA} : 52.9 %
 Efficiency: $N_{actual} = 55.7 / N_{target} = 40^{**}$
 EC controller integrated

* Rated data

**ErP 2015

*** Continuous operation with occasional starts (S1) according to DIN EN 60034-1:2011-02. Occasional starting between -35 °C and -25 °C is permissible. Continuous operation below -25 °C only with special bearings for refrigeration applications on request.

Characteristic curve

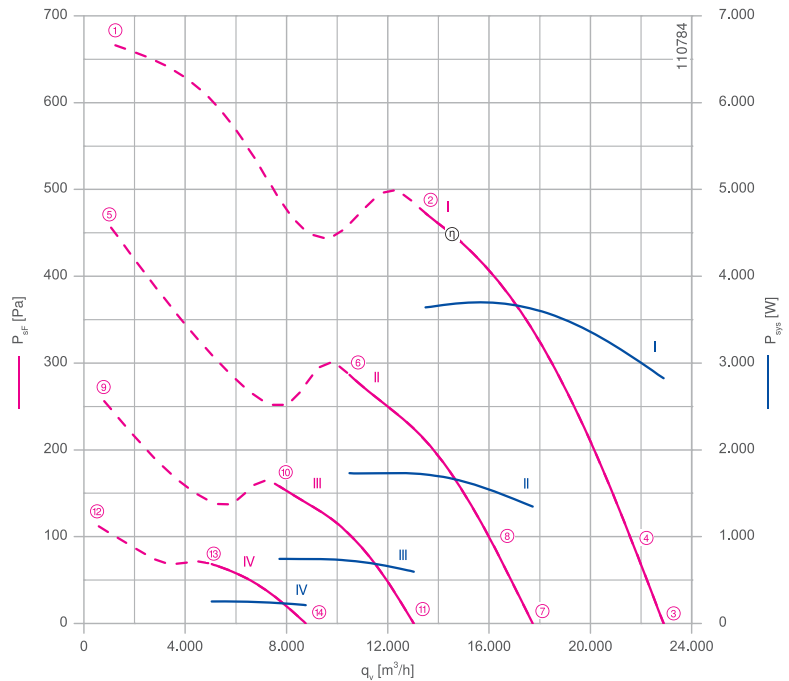

Measured in ZPlus without guard grille in installation type A according to ISO 5801.

Connection diagram Page 172
1360-403

System components Page 110

Dimensions mm

Airflow direction →

Design L - ZPlus Ontop, guard grille suction side

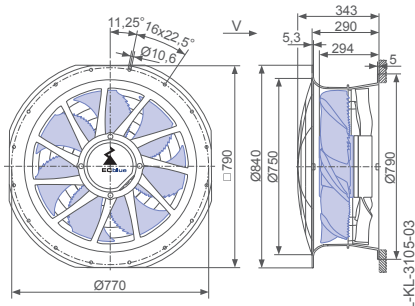

Design Q - ZPlus with adapter plate, guard grille suction side

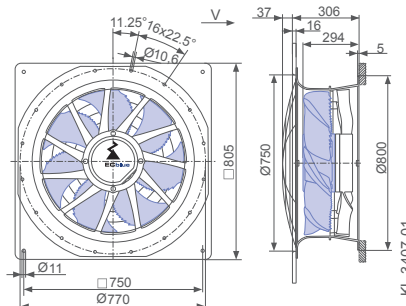

← Airflow direction

Design L - ZPlus Ontop without guard grille

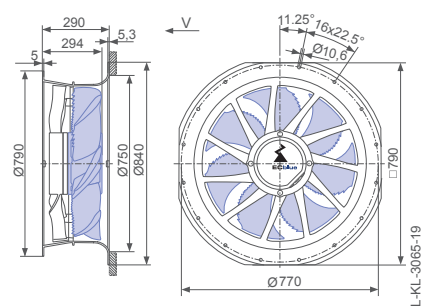

Performance data

Type	Characteristic curve	Speed n min ⁻¹	Operating point	Current	Input power	Acoustic pressure level 7m	Specific power
				I A	P _{sys} W	L _{pA} dB(A)	P _{spez} Wh/1000m ³
ZN063-ZL_GL.V7P3	I	1600	①	5.60	3700		
			②	5.60	3600		273.2
			③	4.40	2800	65	123.4
			④	4.80	3100	64	143.4
	II	1250	⑤	3.20	2100		
			⑥	2.70	1700		166.6
			⑦	2.10	1350	59	76.0
			⑧	2.40	1550	58	96.8
	III	930	⑨	1.50	920		
			⑩	1.25	740		96.5
			⑪	1.05	600	53	45.8
			⑫	0.66	300		
	IV	620	⑬	0.58	250		49.9
			⑭	0.52	210	42	24.1

Current values determined at 400V

Fan ordering information

Design	Airflow direction		Airflow direction			
	L (guard grille suction side) Ontop	Q (guard grille suction side)	L (without guard grille) Ontop	L (guard grille pressure side) Ontop	Q (without guard grille) side	Q (guard grille pressure side)
Type	ZN063-ZIL.GL.V7P3	ZN063-ZIQ.GL.V7P3	ZN063-ZIL.GL.V7P3	ZN063-ZIL.GL.V7P3	ZN063-ZIQ.GL.V7P3	ZN063-ZIQ.GL.V7P3
Article no.	169049	169050	168049	168050	168051	168052
Weight kg	37.10	39.20	35.20	36.20	37.20	38.20

ZAplus attachable on both sides.

Control technology

Control module UNIcon Zenec switch



Page 130



Page 158

Design L - ZAplus Ontop, guard grille pressure side

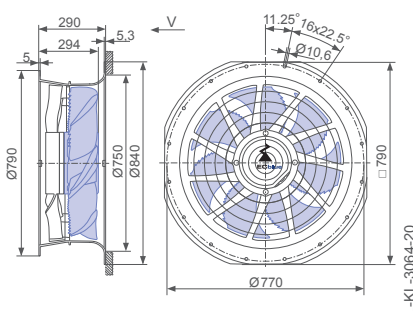

Design Q - ZAplus with adapter plate, without guard grille

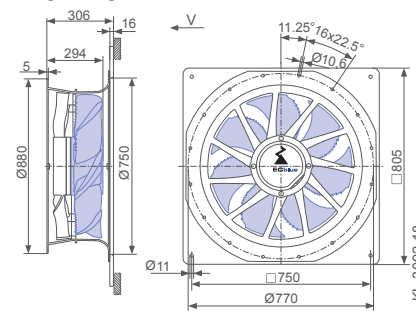

Design Q - ZAplus with adapter plate, guard grille pressure side

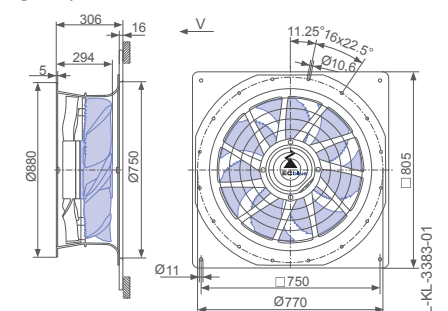

FE2owlet-ECblue with ZPlus

for three phase alternating current, 380-480 V

ZN071



Description

Motor technology: EC
 Rated voltage U_N : 3- 380-480 V*
 Rated frequency f_N : 50/60 Hz*
 Input power P_{sys} : 4.20 kW*
 Rated current I_N : 6.80- 5.40 A*
 Rated speed n_N : 1530 min⁻¹*
 Thermal class: THCL155*
 Min. permitted ambient temperature $t_{R(min)}$: -35 °C ***
 Max. permitted ambient temperature $t_{R(max)}$: 40 °C
 Electrical connection: Integrated controller
 Number of blades: 7
 Degree of protection : IP55
 Motor protection: Integrated active temperature management
 Blades: Aluminium, powder-coated, ultramarine blue
 Rotor: Aluminium, 2 coat paint, ultramarine blue
 Conformity: ErP 2015, CE, UL

ErP-data

Efficiency η_{statA} : 54.2 %
 Efficiency: $N_{actual} = 56.6 / N_{target} = 40^{**}$
 EC controller integrated

* Rated data

**ErP 2015

*** Continuous operation with occasional starts (S1) according to DIN EN 60034-1:2011-02. Occasional starting between -35 °C and -25 °C is permissible. Continuous operation below -25 °C only with special bearings for refrigeration applications on request.

Characteristic curve

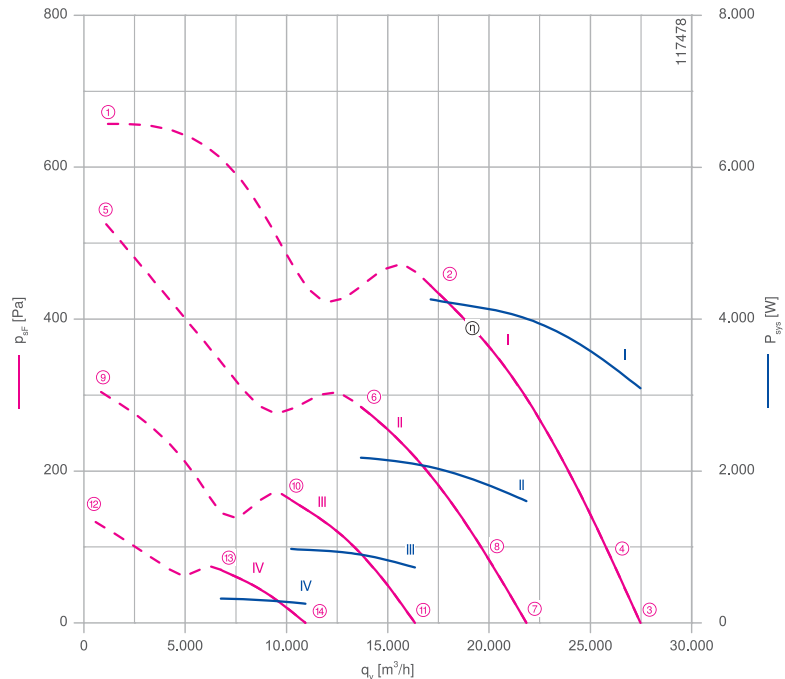

Measured in ZPlus without guard grille in installation type A according to ISO 5801.

Connection diagram Page 172
1360-403

System components Page 110

Dimensions mm

Airflow direction

Design L - ZPlus Ontop, guard grille suction side

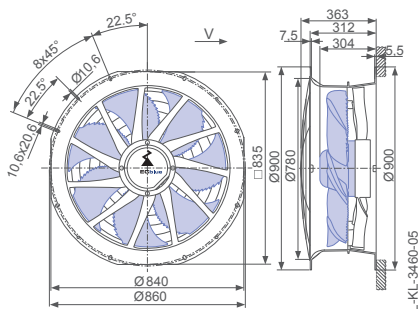

Airflow direction

Design L - ZPlus Ontop without guard grille

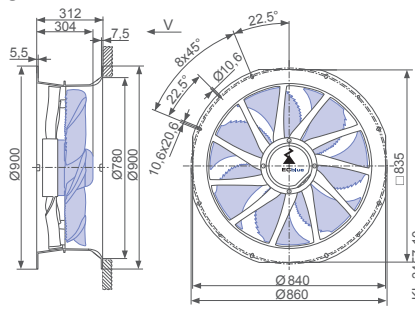

Design L - ZPlus Ontop, guard grille pressure side

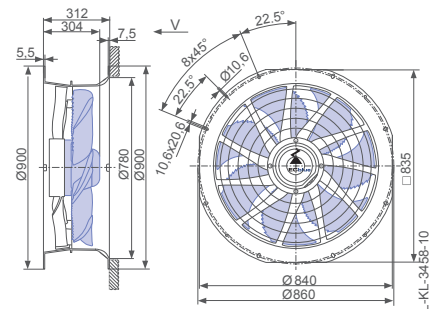

Performance data

Type	Characteristic curve	Speed n min ⁻¹	Operating point	Current	Input power	Acoustic pressure level 7m	Specific power
				I A	P _{sys} W	L _{pA} dB(A)	P _{spez} Wh/1000m ³
ZN071-ZL_GL_7P4	I	1530	①	7.00	4600		
			②	6.60	4200		252.9
			③	4.80	3100	64	112.4
			④	5.20	3500	64	133.7
	II	1220	⑤	5.00	3200		
			⑥	3.40	2200		161.5
			⑦	2.50	1600	58	73.4
			⑧	2.90	1900	57	94.7
	III	920	⑨	2.20	1400		
			⑩	1.60	980		95.8
			⑪	1.25	720	50	44.6
	IV	610	⑫	0.92	460		
			⑬	0.72	320		48.1
			⑭	0.62	250	39	23.0

Current values determined at 400V

Fan ordering information

	Airflow direction →	← Airflow direction	
Design	L (guard grille suction side) Ontop	L (without guard grille) Ontop	L (guard grille pressure side) Ontop
Type	ZN071-ZIL.GL.V7P4	ZN071-ZIL.GL.V7P4	ZN071-ZIL.GL.V7P4
Article no.	170364	168053	168054
Weight kg	37.80	35.10	36.40
ZApus attachable on both sides.			

Control technology

Control module UNIcon Zenec switch



Page 130



Page 158

FE2owlet-ECblue with ZPlus

for three phase alternating current, 380-480 V

ZN080



Description

Motor technology: EC
 Rated voltage U_N : 3- 380-480 V*
 Rated frequency f_N : 50/60 Hz*
 Input power P_{sys} : 3.50 kW*
 Rated current I_N : 5.60- 4.40 A*
 Rated speed n_N : 1180 min⁻¹*
 Thermal class: THCL155*
 Min. permitted ambient temperature $t_{R(min)}$: -35 °C ***
 Max. permitted ambient temperature $t_{R(max)}$: 40 °C
 Electrical connection: Integrated controller
 Number of blades: 7
 Degree of protection : IP55
 Motor protection: Integrated active temperature management
 Blades: Aluminium, powder-coated, ultramarine blue
 Rotor: Aluminium, 2 coat paint, ultramarine blue
 Conformity: ErP 2015, CE, UL

ErP-data

Efficiency η_{statA} : 56.3 %
 Efficiency: $N_{actual} = 59.2 / N_{target} = 40^{**}$
 EC controller integrated

* Rated data

**ErP 2015

*** Continuous operation with occasional starts (S1) according to DIN EN 60034-1:2011-02. Occasional starting between -35 °C and -25 °C is permissible. Continuous operation below -25 °C only with special bearings for refrigeration applications on request.

Characteristic curve

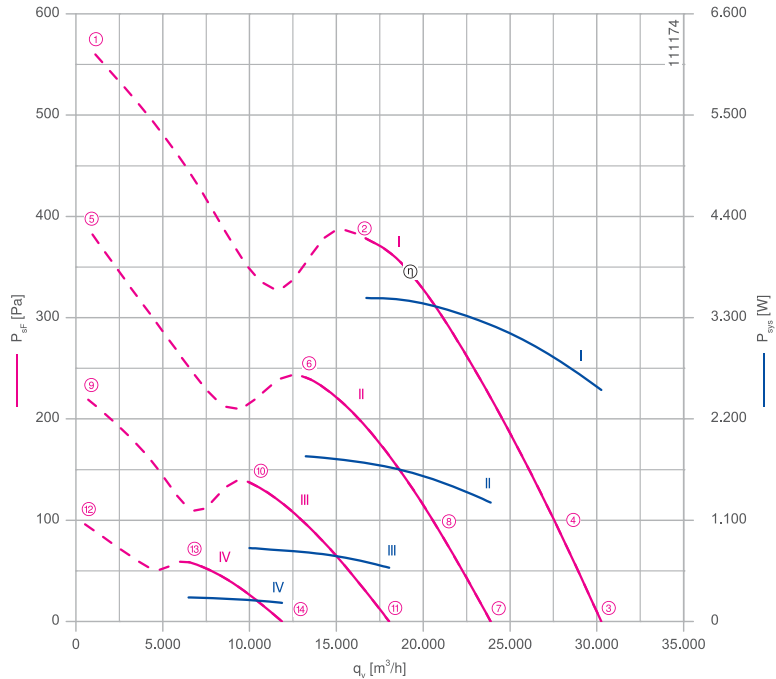

Measured in ZPlus without guard grille in installation type A according to ISO 5801.

Connection diagram Page 172
1360-403

System components Page 110

Dimensions mm

Airflow direction →

Design L - ZPlus Ontop, guard grille suction side

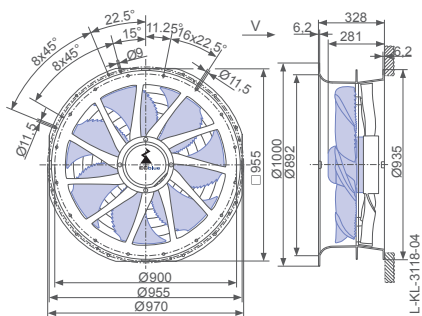

Design Q - ZPlus with adapter plate, guard grille suction side

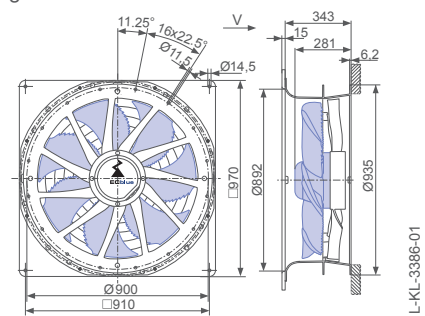

← Airflow direction

Design L - ZPlus Ontop without guard grille

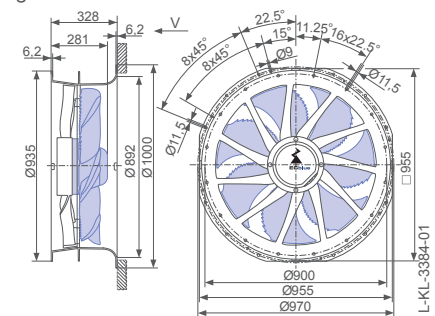

Performance data

Type	Characteristic curve	Speed n min ⁻¹	Operating point	Current	Input power	Acoustic pressure level 7m	Specific power
				I A	P _{sys} W	L _{pA} dB(A)	P _{spez} Wh/1000m ³
ZN080-ZL_GL.V7P3	I	1180	①	6.80	4600		
			②	5.40	3500		211.7
			③	3.90	2500	59	83.1
			④	4.40	2900	57	104.2
	II	940	⑤	3.80	2500		
			⑥	2.80	1800		135.2
			⑦	2.10	1300	53	54.1
			⑧	2.50	1550	51	76.0
	III	710	⑨	1.75	1100		
			⑩	1.35	800		79.7
			⑪	1.05	580	46	32.3
			⑫	0.74	340		
	IV	470	⑬	0.62	260		
			⑭	0.52	200	37	17.0

Current values determined at 400V

Fan ordering information

Design	Airflow direction		Airflow direction			
	L (guard grille suction side) Ontop	Q (guard grille suction side)	L (without guard grille) Ontop	L (guard grille pressure side) Ontop	Q (without guard grille) side	Q (guard grille pressure side)
Type	ZN080-ZIL.GL.V7P3	ZN080-ZIQ.GL.V7P3	ZN080-ZIL.GL.V7P3	ZN080-ZIL.GL.V7P3	ZN080-ZIQ.GL.V7P3	ZN080-ZIQ.GL.V7P3
Article no.	169051	169052	168057	168058	168059	168060
Weight kg	43.80	46.90	40.80	42.20	43.90	45.20

ZAplus attachable on both sides.

Control technology

Control module UNIcon Zenec switch



Page 130



Page 158

Design L - ZAplus Ontop, guard grille pressure side

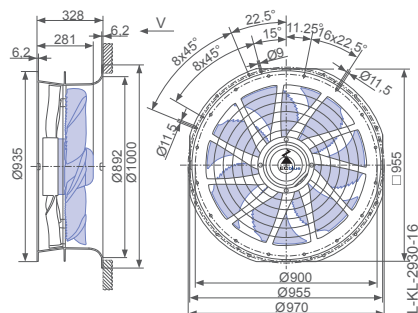

Design Q - ZAplus with adapter plate, without guard grille

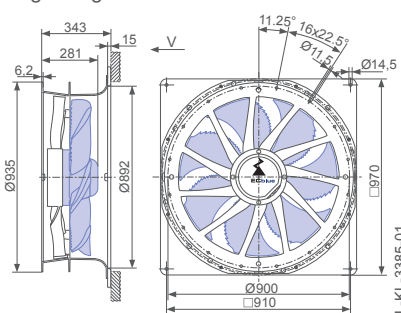

Design Q - ZAplus with adapter plate, guard grille pressure side

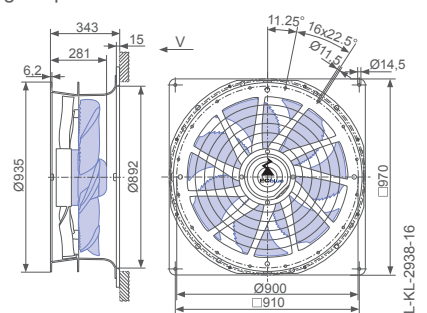

FE2owlet-ECblue with ZPlus

for three phase alternating current, 380-480 V

ZN080



Description

Motor technology: EC
 Rated voltage U_N : 3- 380-480 V*
 Rated frequency f_N : 50/60 Hz*
 Input power P_{sys} : 4.00 kW*
 Rated current I_N : 6.60- 5.20 A*
 Rated speed n_N : 1250 min⁻¹*
 Thermal class: THCL155*
 Min. permitted ambient temperature $t_{R(min)}$: -35 °C ***
 Max. permitted ambient temperature $t_{R(max)}$: 45 °C
 Electrical connection: Integrated controller
 Number of blades: 7
 Degree of protection : IP55
 Motor protection : Integrated active temperature management
 Blades: Aluminium, powder-coated, ultramarine blue
 Rotor: Aluminium, 2 coat paint, ultramarine blue
 Conformity: ErP 2015, CE, UL

ErP-data

Efficiency η_{statA} : 57.7 %
 Efficiency: $N_{actual} = 60.2 / N_{target} = 40^{**}$
 EC controller integrated

* Rated data

**ErP 2015

*** Continuous operation with occasional starts (S1) according to DIN EN 60034-1:2011-02. Occasional starting between -35 °C and -25 °C is permissible. Continuous operation below -25 °C only with special bearings for refrigeration applications on request.

Characteristic curve

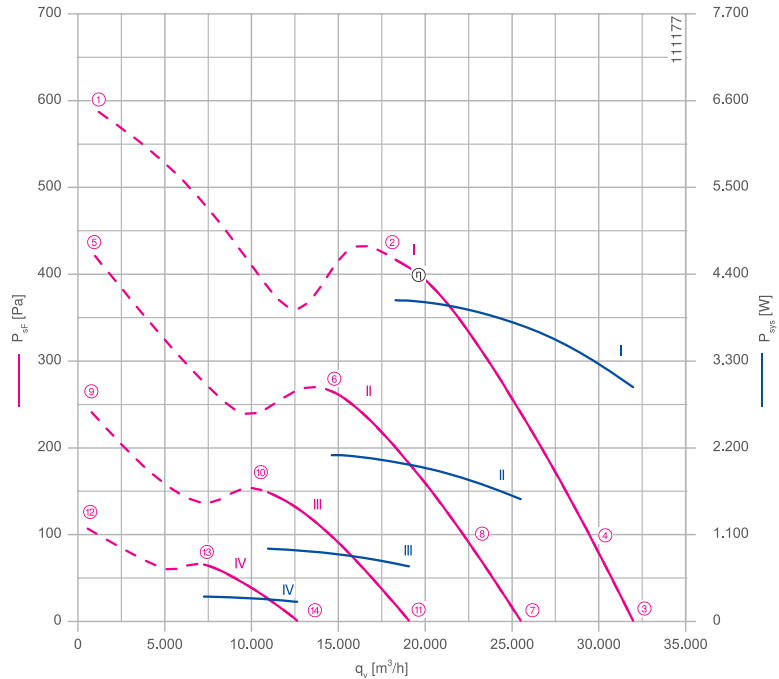

Measured in ZPlus without guard grille in installation type A according to ISO 5801.

Connection diagram Page 172
1360-403

System components Page 110

Dimensions mm

Airflow direction

Design L - ZPlus Ontop, guard grille suction side

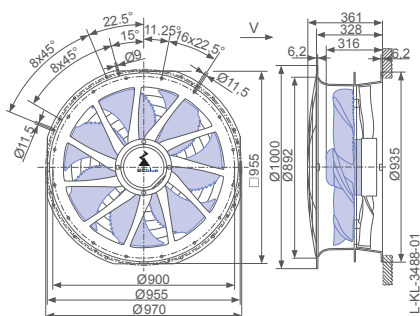

Design Q - ZPlus with adapter plate, guard grille suction side

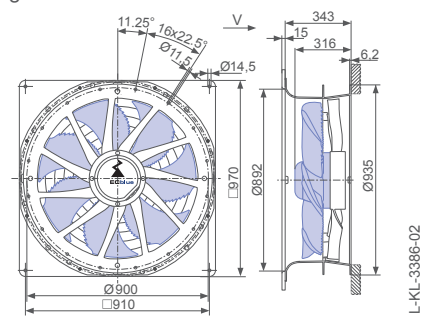

Design L - ZPlus Ontop without guard grille

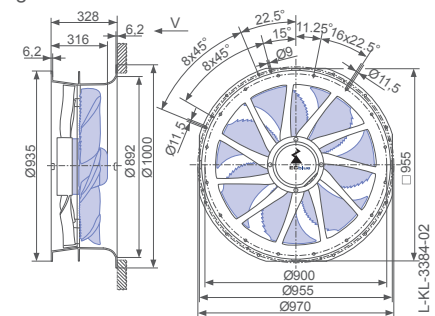

Performance data

Type	Characteristic curve	Speed n min ⁻¹	Operating point	Current	Input power	Acoustic pressure level 7m	Specific power
				I A	P _{sys} W	L _{pA} dB(A)	P _{spez} Wh/1000m ³
ZN080-ZL_GQ.V7P3	I	1250	①	7.40	4800		
			②	6.20	4000		224.7
			③	4.60	3000	61	92.9
			④	5.20	3400	60	113.7
	II	1000	⑤	4.40	2900		
			⑥	3.20	2100		146.0
			⑦	2.40	1550	55	60.8
			⑧	2.80	1850	53	82.9
	III	750	⑨	2.00	1250		
			⑩	1.55	920		85.4
			⑪	1.20	700	48	36.6
			⑫	0.86	420		
	IV	500	⑬	0.70	310		
			⑭	0.60	250	39	19.7

Current values determined at 400V

Fan ordering information

Design	Airflow direction		Airflow direction			
	L (guard grille suction side) Ontop	Q (guard grille suction side)	L (without guard grille) Ontop	L (guard grille pressure side) Ontop	Q (without guard grille) side)	Q (guard grille pressure side)
Type	ZN080-ZIL.GQ.V7P3	ZN080-ZIQ.GQ.V7P3	ZN080-ZIL.GQ.V7P3	ZN080-ZIL.GQ.V7P3	ZN080-ZIQ.GQ.V7P3	ZN080-ZIQ.GQ.V7P3
Article no.	169053	169054	168061	168062	168063	168064
Weight kg	50.60	54.00	47.50	49.00	50.60	52.10

ZAplus attachable on both sides.

Control technology

Control module UNIcon Zenec switch



Page 130



Page 158

Design L - ZAplus Ontop, guard grille pressure side

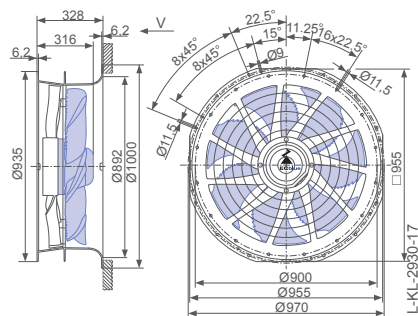

Design Q - ZAplus with adapter plate, without guard grille

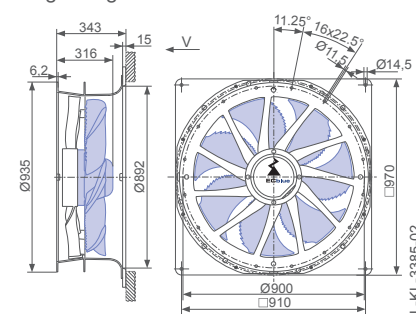

Design Q - ZAplus with adapter plate, guard grille pressure side

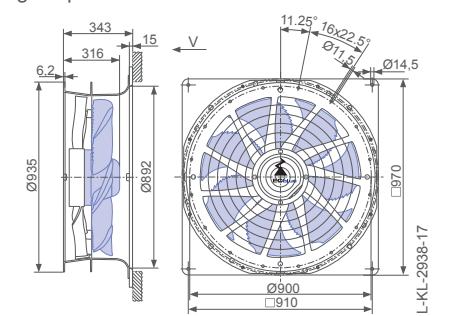

FE2owlet-ECblue with ZPlus

for three phase alternating current, 380-480 V

ZN091



Description

Motor technology: EC
 Rated voltage U_N : 3- 380-480 V*
 Rated frequency f_N : 50/60 Hz*
 Input power P_{sys} : 3.40 kW*
 Rated current I_N : 5.40- 4.20 A*
 Rated speed n_N : 1130 min⁻¹*
 Thermal class: THCL155*
 Min. permitted ambient temperature $t_{R(min)}$: -35 °C ***
 Max. permitted ambient temperature $t_{R(max)}$: 40 °C
 Electrical connection: Integrated controller
 Number of blades: 5
 Degree of protection : IP55
 Motor protection: Integrated active temperature management
 Blades: Aluminium, powder-coated, ultramarine blue
 Rotor: Aluminium, 2 coat paint, ultramarine blue
 Conformity: ErP 2015, CE, UL

ErP-data

Efficiency η_{statA} : 61.3 %
 Efficiency: $N_{actual} = 64.5 / N_{target} = 40^{**}$
 EC controller integrated

* Rated data

**ErP 2015

*** Continuous operation with occasional starts (S1) according to DIN EN 60034-1:2011-02. Occasional starting between -35 °C and -25 °C is permissible. Continuous operation below -25 °C only with special bearings for refrigeration applications on request.

Characteristic curve

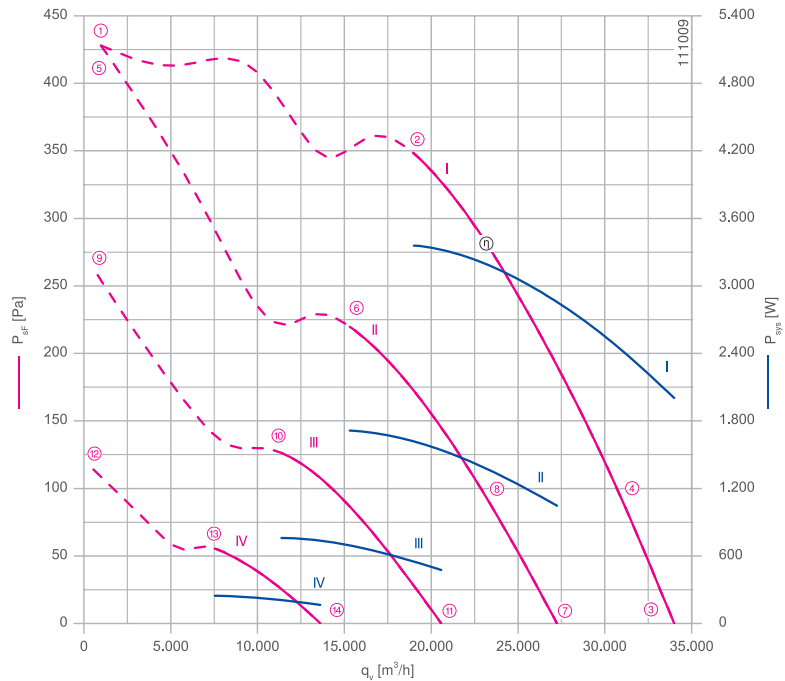

Measured in ZPlus without guard grille in installation type A according to ISO 5801.

Connection diagram Page 172
1360-403

System components Page 110

Dimensions mm

Airflow direction →

Design L - ZPlus Ontop, guard grille suction side

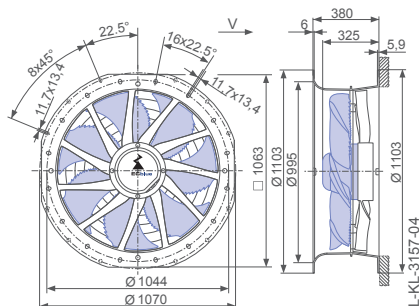

Design Q - ZPlus with adapter plate, guard grille suction side

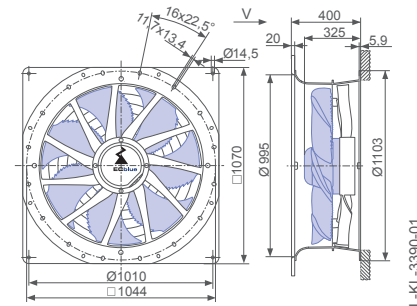

← Airflow direction

Design L - ZPlus Ontop without guard grille

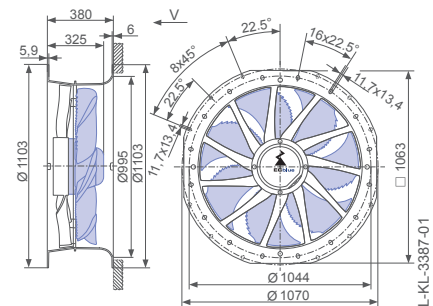

Performance data

Type	Characteristic curve	Speed n min ⁻¹	Operating point	Current	Input power	Acoustic pressure level 7m	Specific power
				I A	P _{sys} W	L _{pA} dB(A)	P _{spez} Wh/1000m ³
ZN091-ZL_GL.V5P1	I	1130	①	4.40	2900		
			②	5.20	3400		177.6
			③	3.10	2000	61	59.0
			④	3.80	2500	60	80.0
	II	900	⑤	4.40	2900		
			⑥	2.70	1700		113.8
			⑦	1.70	1050	55	38.4
			⑧	2.20	1400	53	61.2
	III	680	⑨	2.10	1350		
			⑩	1.30	760		66.8
			⑪	0.90	480	47	23.1
			⑫	0.82	420		
	IV	450	⑬	0.58	250		
			⑭	0.44	160	37	12.1

Current values determined at 400V

Fan ordering information

Design	Airflow direction		Airflow direction			
	L (guard grille suction side) Ontop	Q (guard grille suction side)	L (without guard grille) Ontop	L (guard grille pressure side) Ontop	Q (without guard grille) side	Q (guard grille pressure side)
Type	ZN091-ZIL.GL.V5P1	ZN091-ZIQ.GL.V5P1	ZN091-ZIL.GL.V5P1	ZN091-ZIL.GL.V5P1	ZN091-ZIQ.GL.V5P1	ZN091-ZIQ.GL.V5P1
Article no.	169055	169056	168065	168066	168067	168068
Weight kg	46.70	50.50	42.90	44.80	46.70	48.60

ZAplus attachable on both sides.

Control technology

Control module UNIcon Zenec switch



Page 130



Page 158

Design L - ZAplus Ontop, guard grille pressure side

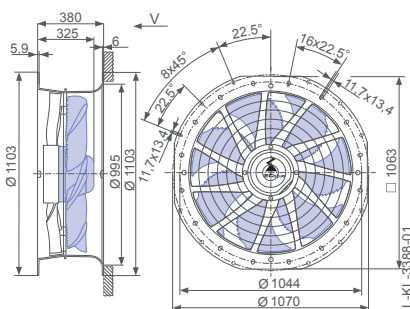

Design Q - ZAplus with adapter plate, without guard grille

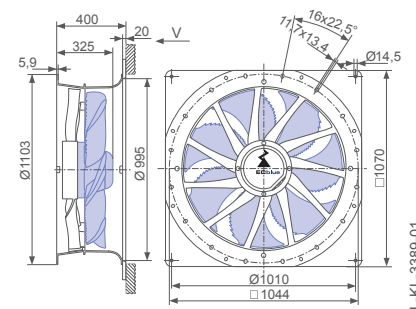

Design Q - ZAplus with adapter plate, guard grille pressure side

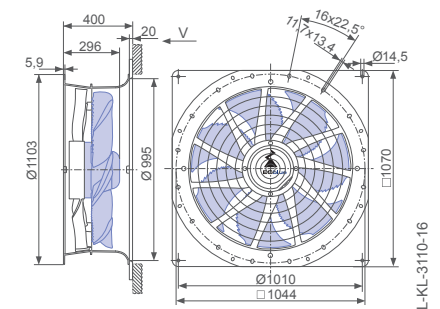

FE2owlet-ECblue with ZPlus

for three phase alternating current, 380-480 V

ZN091



Description

Motor technology: EC
 Rated voltage U_N : 3- 380-480 V*
 Rated frequency f_N : 50/60 Hz*
 Input power P_{sys} : 3.90 kW*
 Rated current I_N : 6.20- 5.00 A*
 Rated speed n_N : 1180 min⁻¹*
 Thermal class: THCL155*
 Min. permitted ambient temperature $t_{R(min)}$: -35 °C ***
 Max. permitted ambient temperature $t_{R(max)}$: 40 °C
 Electrical connection: Integrated controller
 Number of blades: 5
 Degree of protection : IP55
 Motor protection: Integrated active temperature management
 Blades: Aluminium, powder-coated, ultramarine blue
 Rotor: Aluminium, 2 coat paint, ultramarine blue
 Conformity: ErP 2015, CE, UL

ErP-data

Efficiency η_{statA} : 62.1 %
 Efficiency: $N_{actual} = 64.9 / N_{target} = 40^{**}$
 EC controller integrated

* Rated data

**ErP 2015

*** Continuous operation with occasional starts (S1) according to DIN EN 60034-1:2011-02. Occasional starting between -35 °C and -25 °C is permissible. Continuous operation below -25 °C only with special bearings for refrigeration applications on request.

Characteristic curve

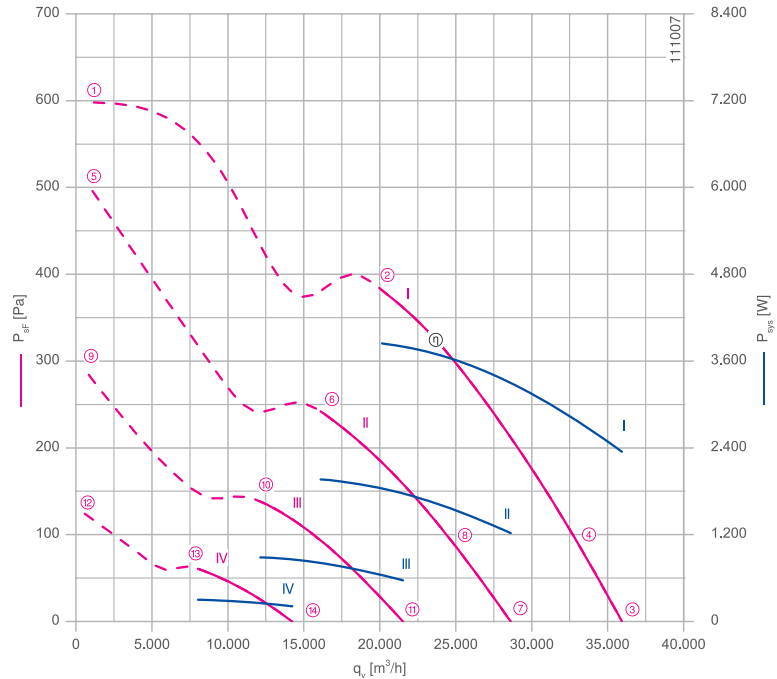

Measured in ZPlus without guard grille in installation type A according to ISO 5801.

Connection diagram Page 172
1360-403

System components Page 110

Dimensions mm

Airflow direction →

Design L - ZPlus Ontop, guard grille suction side

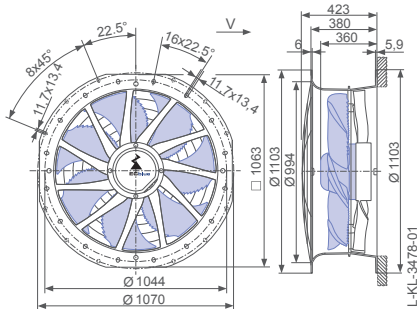

Design Q - ZPlus with adapter plate, guard grille suction side

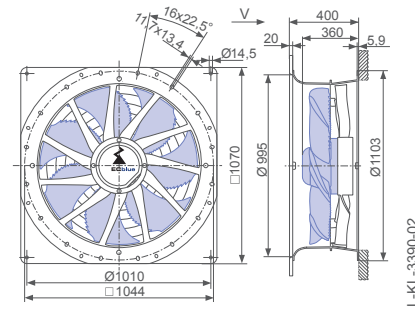

← Airflow direction

Design L - ZPlus Ontop without guard grille

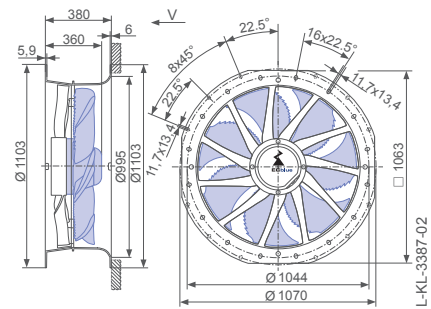

Performance data

Type	Characteristic curve	Speed n min ⁻¹	Operating point	Current	Input power	Acoustic pressure level 7m	Specific power
				I A	P _{sys} W	L _{pA} dB(A)	P _{spez} Wh/1000m ³
ZN091-ZL_GQ.V5P1	I	1180	①	7.20	4800		
			②	5.80	3800		191.1
			③	3.60	2300	63	65.3
			④	4.40	2800	62	85.9
	II	940	⑤	5.40	3500		
			⑥	3.10	1950		122.6
			⑦	1.95	1200	56	42.7
			⑧	2.50	1600	55	64.8
	III	710	⑨	2.40	1550		
			⑩	1.50	880		73.0
			⑪	1.05	560	48	26.4
			⑫	0.94	480		
	IV	470	⑬	0.68	300		
			⑭	0.54	210	39	14.7

Current values determined at 400V

Fan ordering information

Design	Airflow direction		Airflow direction			
	L (guard grille suction side) Ontop	Q (guard grille suction side)	L (without guard grille) Ontop	L (guard grille pressure side) Ontop	Q (without guard grille) side	Q (guard grille pressure side)
Type	ZN091-ZIL.GQ.V5P1	ZN091-ZIQ.GQ.V5P1	ZN091-ZIL.GQ.V5P1	ZN091-ZIL.GQ.V5P1	ZN091-ZIQ.GQ.V5P1	ZN091-ZIQ.GQ.V5P1
Article no.	169057	169058	168069	168070	168071	168072
Weight kg	53.30	57.10	49.70	51.60	53.60	55.50

ZAplus attachable on both sides.

Control technology

Control module UNIcon Zenec switch



Page 130



Page 158

Design L - ZAplus Ontop, guard grille pressure side

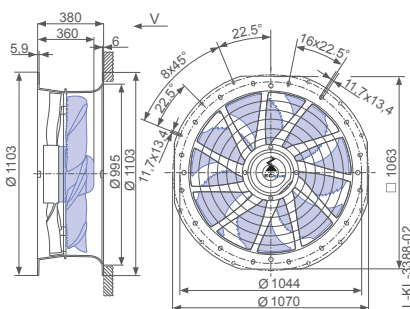

Design Q - ZAplus with adapter plate, without guard grille

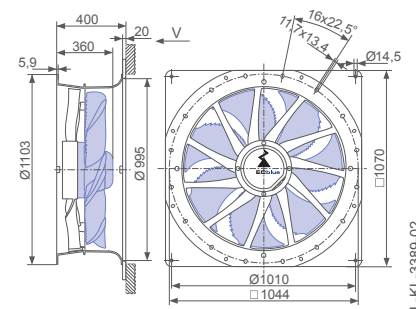

Design Q - ZAplus with adapter plate, guard grille pressure side

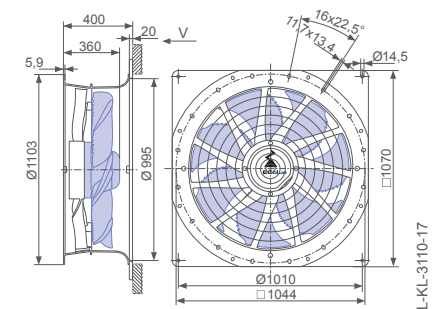

FC

for three-phase alternating current



Description

Motor technology: AC
Thermal class: THCL155
Min. authorised media temperature $t_{R(min)}$: 3~ -40 °C***, or 1~ -25 °C
Min. authorised media temperature $t_{R(min)}$: -10 °C (wall ring plate made of composite material)
Max. authorised media temperature $t_{R(max)}$: 40 °C
Wall ring plate material: * galvanised steel sheet, ** composite material
Electrical connection: Terminal box
Protection class: IP54
Motor protection: Thermostat
Blades: Aluminium, 2-layer coating, black
Rotor: Aluminium, 2-layer coating, black
*** Continuous operation with occasional starts (S1) according to DIN EN 60034-1:2011-02. Occasional starting between -40 °C and -25 °C is permissible. Continuous operation below -25 °C only with special bearings for refrigeration applications on request.

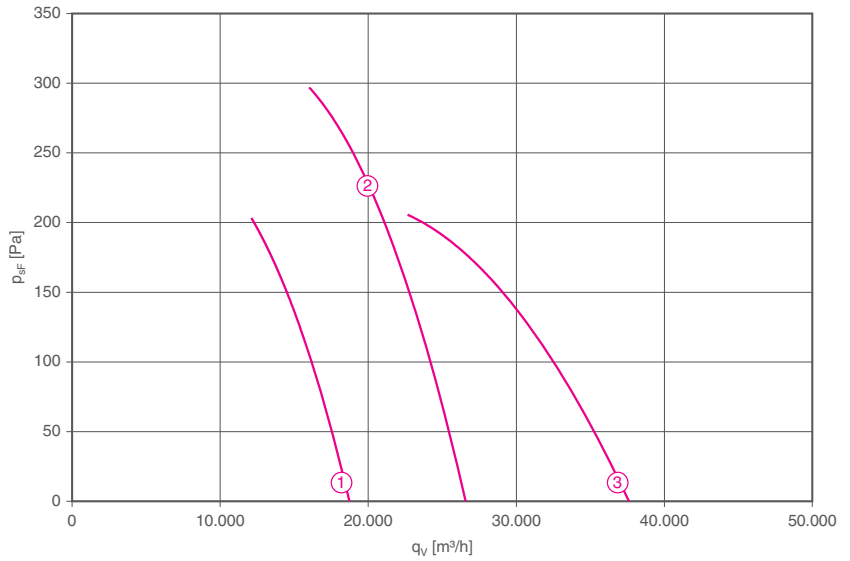

Performance data

High pressure fans

	Type	Article no.	P_1 kW	U +/- 10% V	I A	n min ⁻¹	$p_{sF}=150$ Pa		Weight kg	Connection diagram
							q_v m ³ /h	Wh/1000m ³		
①	FC063-4DQ.6K.A7*	140643	1,9	3~400	3,2	1360	14500	128	26,5	106XB
	FC063-4DT.6K.A7	141346	1,9	3~400	3,2	1360	14500	128	21,0	106XB
②	FC071-4DQ.6N.A7	134413	3,4	3~400	5,8	1390	22800	140	38,6	106XB
	FC071-4DT.6N.A7	141347	3,4	3~400	5,8	1390	22800	140	21,6	106XB
③	FC091-6DQ.7Q.A7*	140570	3,6	3~400	7,2	890	29000	120	57,2	106XB
	FC091-6DT.7Q.A7	141348	3,6	3~400	7,2	890	29000	120	46,6	106XB

Airflow direction A

Design T - for installation in chimney exhausts, without guard grille

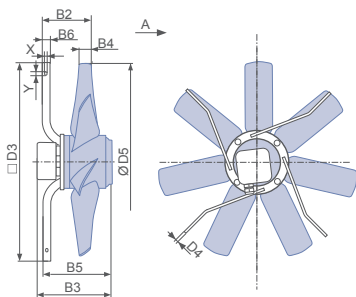

Design Q - square full bell mouth, without guard grille

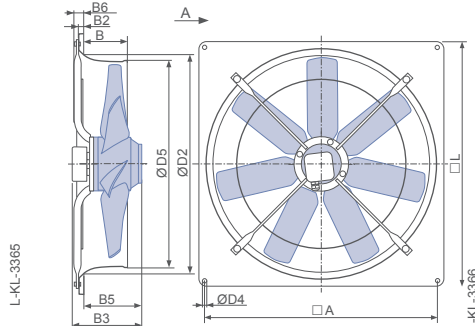

Design Q - square full bell mouth, guard grille suction side

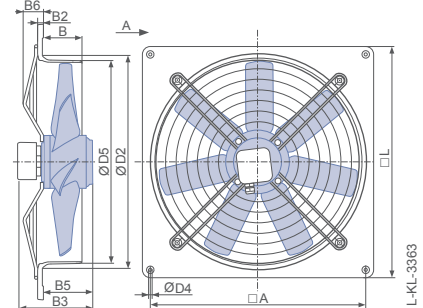

Fans design T without guard grille

Type	Article no.	B4 mm	B2 mm	B3 mm	B5 mm	B6 mm	D3 mm	D5 mm	X mm	Y mm	D4 mm
FC063-4DT.6K.A7	141346	52	174	246	238	25	636	627	9	13	8
FC071-4DT.6N.A7	141347	47	170	246	238	25	720	703	9	13	8
FC091-6DT.7Q.A7	141348	81	215	323	318	30	910	905	9	13	10

Fans design Q without guard grille

Type	Article no.	A mm	B mm	B2 mm	B3 mm	B5 mm	B6 mm	D2 mm	D5 mm	L mm	D4 mm
FC071-4DQ.6N.A7	134413*	810	150	20	271	227	70	763	720	850	14,5
FC091-6DQ.7Q.A7	140570**	1010	183	22	323	276	42	1017	912	1070	14,5

Fans design Q with guard grille

Type	Article no.	A mm	B mm	B2 mm	B3 mm	B5 mm	B6 mm	D2 mm	D5 mm	L mm	D4 mm
FC063-4DQ.6K.A7	140643**	750	128	22	246	174	52	682	647	805	11

Information

Low pressure

High pressure

System components

Control technology

Appendix

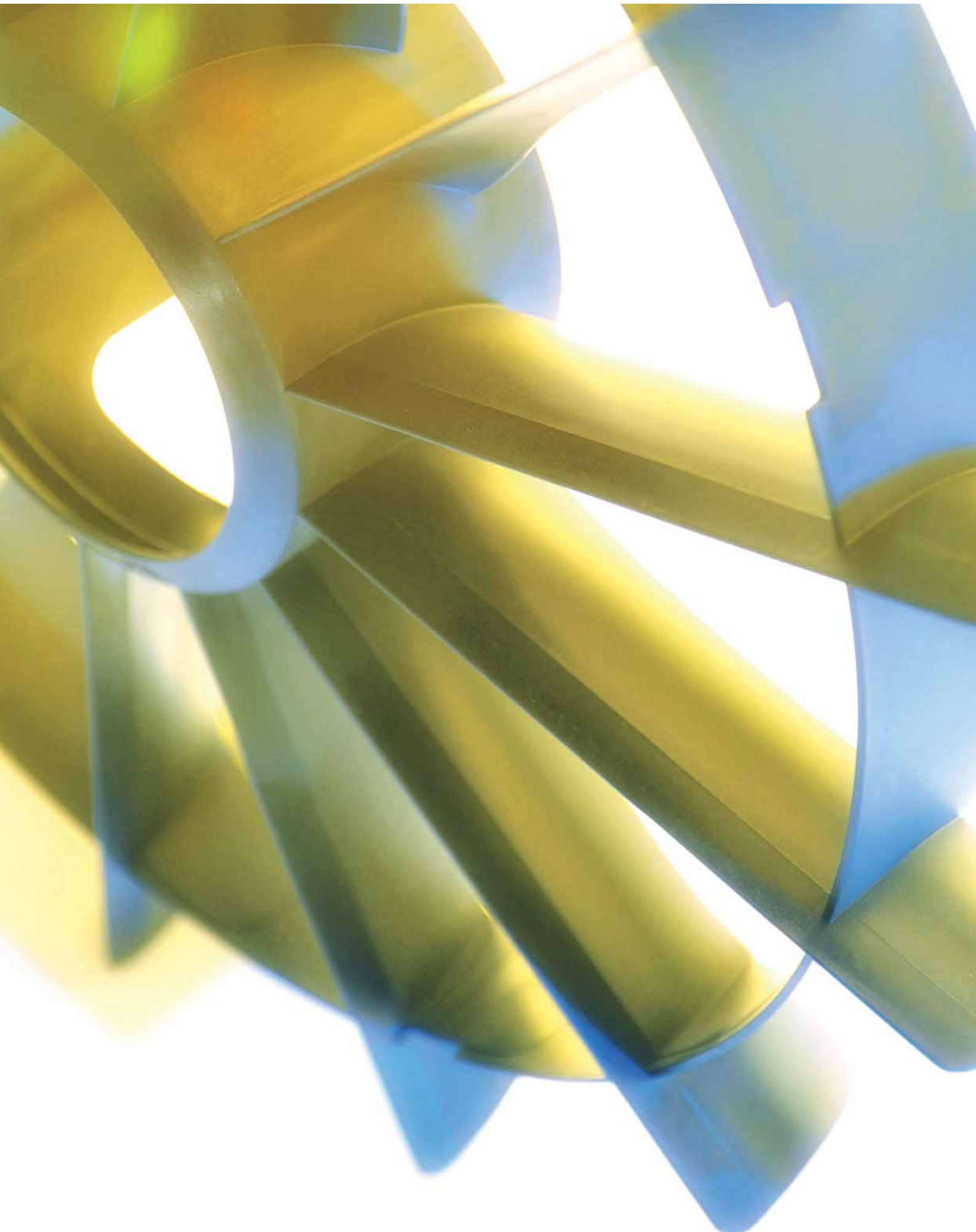

System components

Product overview

Guard grille	Page 112
Wall ring plate	Page 115
Guide vane	Page 116
ZAplus+	Page 120
Optimized sound emission with ZAplus+	Page 122
Backdraft fan shutter	Page 123
Chimney installation kit	Page 124

Information

Low pressure

High pressure

System components

Control technology

Appendix

Guard grille for ZPlus

Description

Material: Steel-wire

Coating: phosphated, powder-coated

Color: RAL 9005, black matt

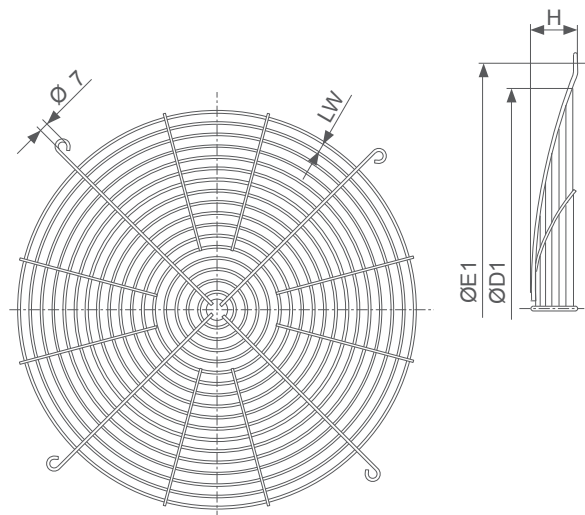
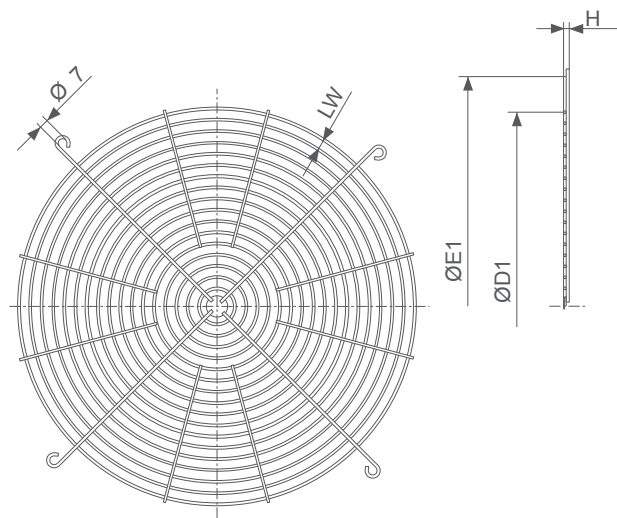
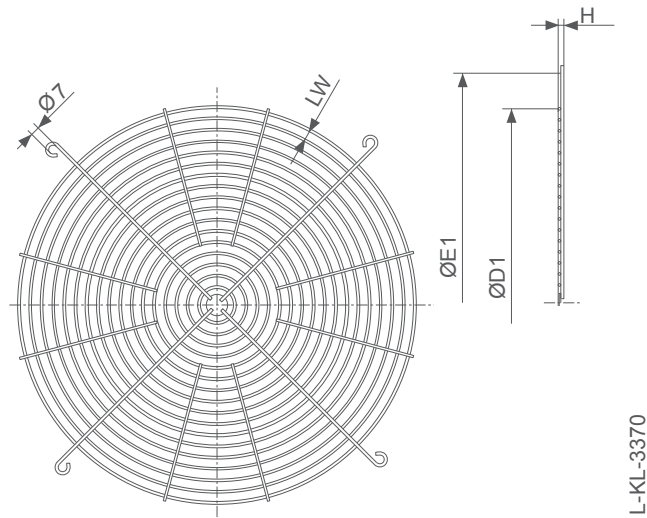

Guard grille on suction side							
Motor size	Size	Article no.	Draw- ing	E1 mm	H mm	D1 mm	LW mm
2_	450	00700873	3370	510	8	475	7,5
	4_	00700874	3372	510	53	475	7,5
	500	00703180	3372	560	47	529	7,5
4M	630	00700576	3370	720	8	670	7,5
	6_	00703463	3372	720	68	677	7,5
	910	00700894	3372	1000	58	945	7,5
6K	800	00700163	3370	900	8	840	7,5
6N	800	00702900	3372	900	27	840	7,5
7_	910	00700894	3372	1000	58	945	7,5
	BD	00700873	3370	510	8	475	7,5
	500	00703463	3372	560	47	529	7,5
BD	630	00700576	3370	720	8	670	7,5
	710	00289811					
	D_	00703180	3372	560	47	529	7,5
D_	630	00700576	3370	720	8	670	7,5
	710	00289811					
	800	00700163	3370	900	8	840	7,5
G_	910	00700893	3370	1000	8	938	7,5
	630	00703463	3372	720	68	677	7,5
	710	00702509					
G_	800	00700163	3370	900	8	840	7,5
	910	00700893	3370	1000	8	938	7,5

Guard grille on pressure side							
Motor size	Size	Article no.	Drawing	D1 mm	H mm	D1 mm	LW mm
2_	450	00700872	3371	510	8	460	19,5
	4_	00700872	3371	510	8	460	19,5
	500	00299801	3372	560	47	535	7,5
6_	630	00700182	3371	720	8	635	19,5
	800	00299071	3371	860	8	810	19,5
	910	00700575	3371	1000	8	910	19,5
7_	910	00700575	3371	1000	8	910	19,5
	BD	00700872	3371	510	8	460	19,5
	500	00299801	3372	560	47	535	7,5
BD	710	00701557					
	D_	00299803	3372	560	24	513	7,5
	630	00700182	3371	720	8	635	19,5
D_	710	00701557					
	800	00299070	3370	860	8	810	8,5
	910	00700575	3371	1000	8	910	19,5
G_	630	00700182	3371	720	8	635	19,5
	710	00701557					
	800	00299071	3371	860	8	810	19,5
G_	910	00700575	3371	1000	8	910	19,5



Guard grille for ZPlus

Description

Material: Stainless steel 1.4301

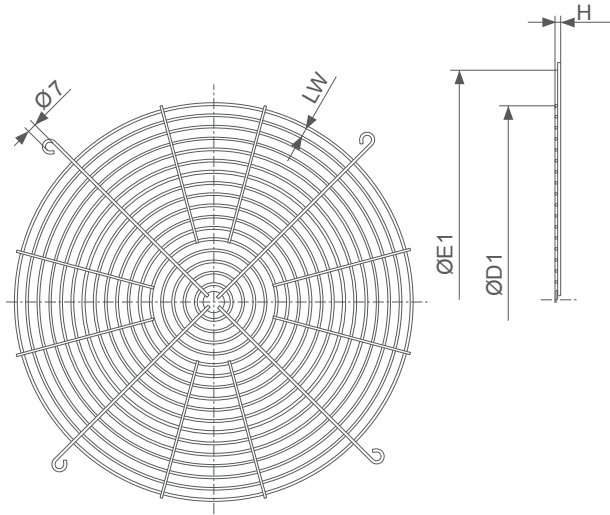

L-KL-3370

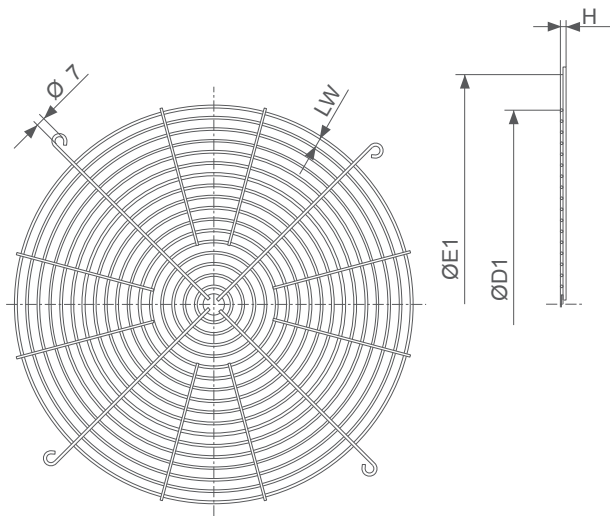

L-KL-3371

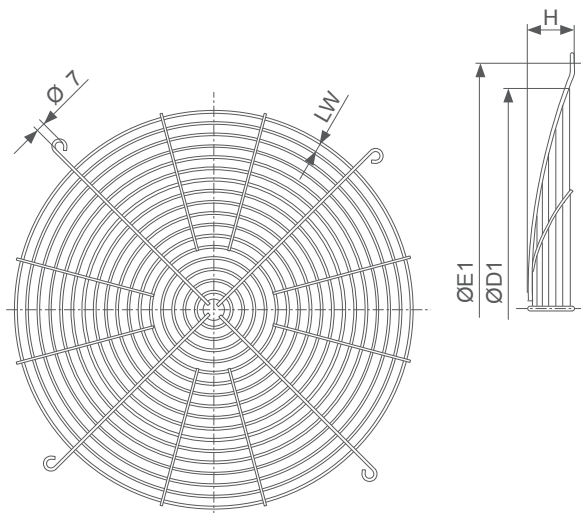

L-KL-3372

Guard grille on suction side

Motor size	Size	Article no.	Drawing	E1 mm	H mm	D1 mm	LW mm
4_/B_/D_	500	00703181	3372	560	47	529	7,5
6_/B_/D_/G_	630	00702461	3372	720	68	677	7,5
6N/D_/G_	800	00702902	3372	900	47	840	7,5
6_/7_/D_/G_	910	00702460	3372	1000	58	945	7,5

Guard grille on pressure side

Motor size	Size	Article no.	Drawing	D1 mm	H mm	D1 mm	LW mm
2_/4_/B_	450	00702458	3370	510	8	460	19,5
4_/B_/D_	500	00702455	3372	560	47	535	7,5
4, 6, D, G	630	00702459	3370	720	8	635	19,5
D	800	00702424	3371	860	8,5	810	11,5
6_/G_	800	00702453	3371	860	8	810	19,5
6_/7_/D_/G_	910	00702462	3370	1000	8	910	19,5

Information

Low pressure

High pressure

System components

Control technology

Appendix

Guard grille for FC fans

Description

Material: Steel-wire

Coating: phosphated, powder-coated

Color: RAL 9005, black matt

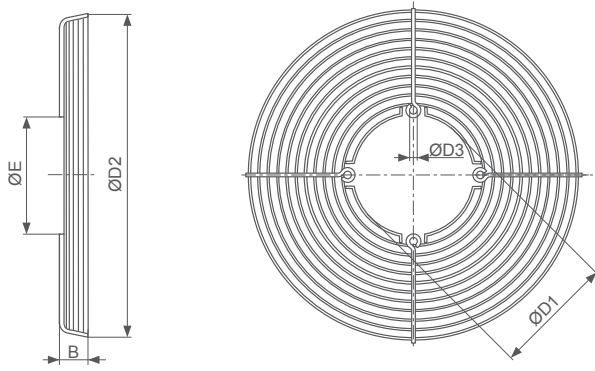

L-KL-3375

Guard grille on pressure side						
Size	Article no.	B mm	D1 mm	D2 mm	D3 mm	E mm
400/450	00242460	41	159	543	6,5	150
500	00242470	41	159	598	6,5	150
630	00242990	24	149	703	6,5	150



Wall ring plate

square full bell mouth, synthetic material, Design Q

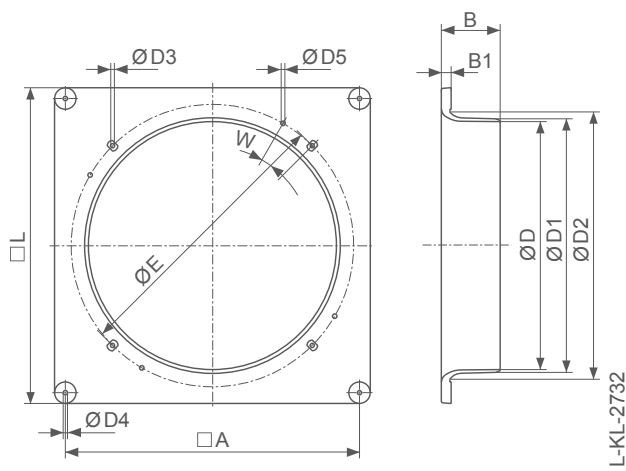

Description

Material: synthetic material
Color: uncoated, black
Delivery includes attaching parts.

Wall ring plate													
Size	Article no.	A	B	B1	D	D1	D2	D3	D4	D5	E	L	W
		mm	mm	mm	mm	mm	mm	mm	mm		mm	mm	°
400	00358507	490	150	23	401	411	466	M6	7,5	-	560	540	-
450	00358508	535	150	25	451	465	515	M6	9,5	-	560	575	-
500	00358509	615	160	25	501,5	515	566	M6	9,5	-	615	655	-
630	00358510	750	150	25	632,5	646,5	686	M6	11	-	720	805	-
630	00358511	750	150	25	632,5	646,5	686	M8	11	M8	720	805	15
630	00358512	750	150	25	632,5	646,5	686	M8	11	-	720	805	-
910	00358513	1010	205	25	912,5	926,5	1020	M10	14,5	-	1115	1070	-
910	00358514	1010	205	25	912,5	926,5	1020	M10	14,5	M8	1115	1070	15

Guiding vane

for airflow direction V and pressure side guard grille



Guiding vane

Guiding vane mounted on fan

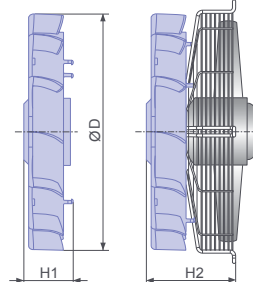

Description

Range: FE2owlet (see type key)

Application range: for improvement of the long flow-range behaviour

Applications: Evaporators, condensers, cold storage, etc.

Advantages:

- Increased throw distance
- Avoidance of "thermal short circuit"
- Minimal pressure losses
- Easy to connect
- Fast retrofiting

Special guiding vane

Material: Polyamide PA6 GF30, UL-listed

Permissible ambient temperature: -30°C...70°C

Mounting: Clip onto the frame support grate

Guiding vane								
for fan			for wire carrying grille		Guiding vane	Dimensions		
Motor	Size	Design	Type	Article no.	Article no.	ØD	H1	H2
	mm					mm	mm	mm
4_	450	K	K	00260180	00291528	479	101	179
	500	K	K	00260160	00286705	528	113	168
		K	K	00287445	00291529	530	101	190
6_	630	Q	S	00288513	00288666	671	118	183
	710	Q	I	00290635	00291514	715	115	178
	800	Q	I	00290636	00291515	805	115	176

Universal guiding vane

Material: Polyamide PA6 GF30, UL-listed

Permissible ambient temperature: -30°C...70°C

Mounting: Clip onto the frame support grate

Guiding vane			
for fan	Guiding vane	Dimensions	
Size	Article no.	ØD	H1
mm		mm	mm
450	00369240	479	120-135
500	00369241	530	120-135
630	00369242	671	140-155
710	00369243	714	114-134
800	00369244	805	114-134



Functional principle

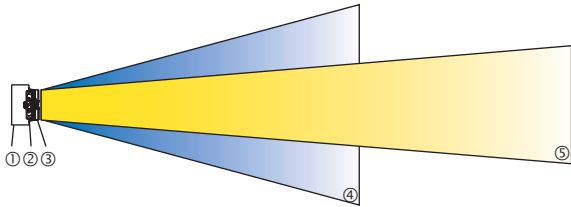

- ① Evaporator
- ② Fan
- ③ Guiding vane
- ④ without Guiding vane
- ⑤ with Guiding vane

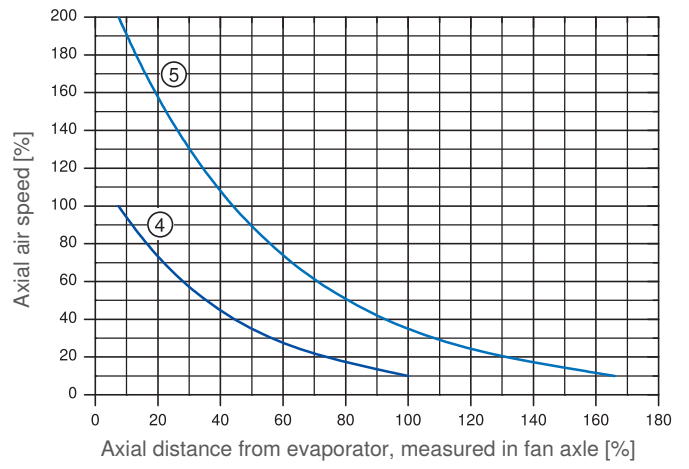

Information

Low pressure

High pressure

System components

Control technology

Appendix

Guiding vane

For chimney installation frame size 650



Description

Operational area: For increasing exhaust air plume

Applications: Chimney installation.

Diameter: 650 mm

For details, see the DLG test report 5642 F (also available for download on the ZIEHL-ABEGG website).

Article no. 00289444

Applications:

- Greater air speed
- Higher exhaust air plume
- Shorter chimney can be used if necessary

Source: DLG test report

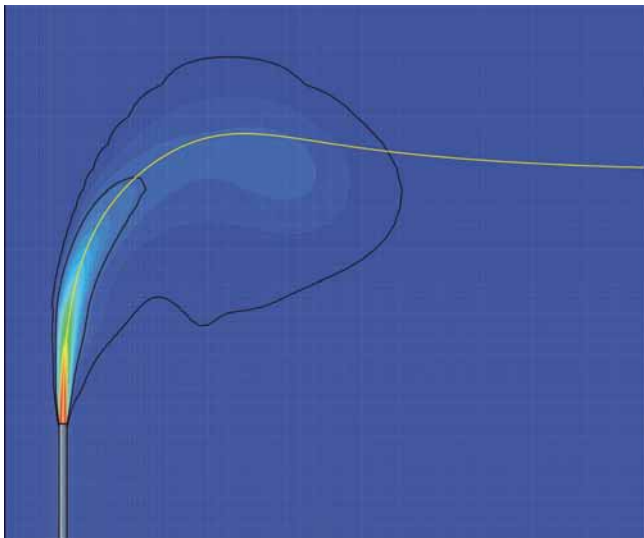

Inflow velocity: 0.3 m/s without guide vane

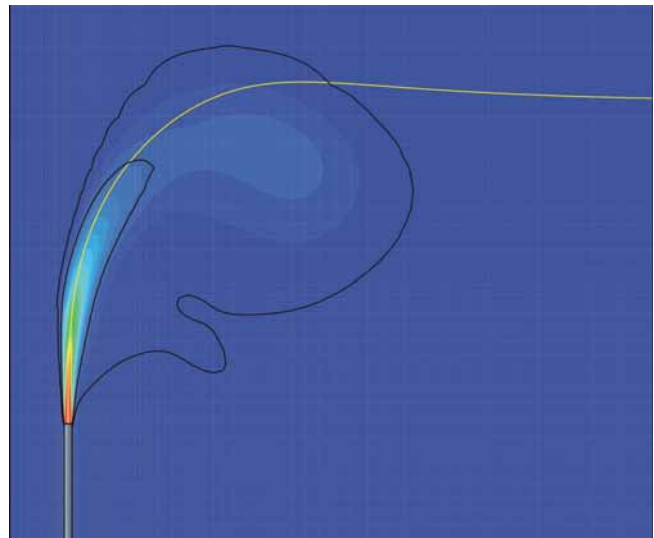

Inflow velocity: 0.3 m/s with guide vane
→ significant increasing exhaust air plume

- Information
- Low pressure
- High pressure
- System components**
- Control technology
- Appendix

ZApus+

Diffusor on ZApus for greater air flow rate in the lower pressure range



Increase in air flow rate ZApus+ vs ZApus

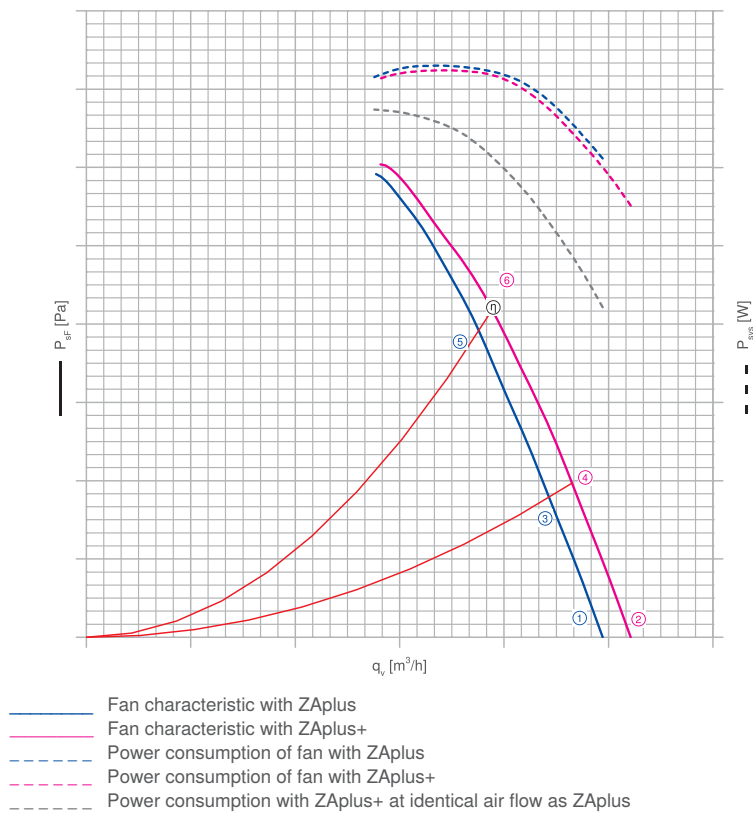

Description

Applications with low pressure losses (including Microchannel)
 Sizes: 500, 630, 800 and 910
 Diffusor: Black-coated metal sheet
 Guard grille: Black-coated steel wire
 Authorised ambient temperature: -50°C...80°C
 Assembly: Screwed to ZApus

The installation kit includes:

- 2 diffusor halves
- 1 guard grille
- 1 fastening kit
- 1 assembly instructions

Advantages:

- Noise level improved by up to 4.5 dB(A)
- Acoustic directivity
- Increased air handling capacity
- Easy to retrofit
- Energy optimisation
- Lower operating costs
- 100% recyclable
- Complies with ErP 2015

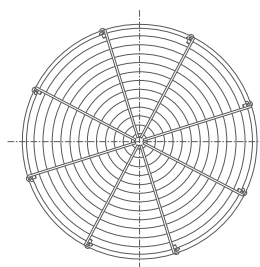
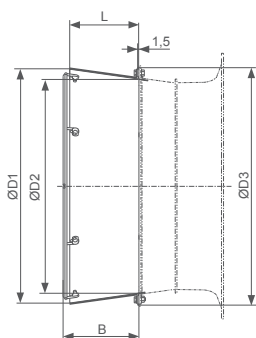

L-KL-3117

ZApus+							
Size	Article no.	Ø D1 mm	Ø D2 mm	Ø D3 mm	B mm	L mm	Weight kg
500	00701319	576	528	579	186	170	5,0
630	00701321	725	675	800	197	180	6,8
800	00701323	908	835	935	197	180	8,6
910	00702652	1006	955	1075	197	180	9,7



Improvement to ZAplus through ZAplus+					
	Operating point		q _v increase*	Energy saving*	Energy saving**
			%	%	%
ZN050-6L_BD.V7P2	①	②	7,0	14,5	30,5
	③	④	6,0	-	21,5
	⑤	⑥	4,0	-	11,5
ZN050-ZL_DC.V7P2	①	②	9,0	14,5	34,0
	③	④	6,5	-	22,5
	⑤	⑥	4,0	-	14,5
ZN050-VD_4I.V7P1	①	②	8,5	9,0	28,5
	③	④	5,5	-	18,0
	⑤	⑥	3,0	-	10,0
ZN050-6E_4F.V7P1	①	②	8,0	6,5	25,5
	③	④	5,5	-	16,5
	⑤	⑥	3,5	-	10,0
ZN050-AD_4C.V7P1	①	②	8,0	7,0	26,0
	③	④	7,5	-	22,0
	⑤	⑥	4,0	-	12,0
ZN063-6L_BD.V7P2	①	②	2,5	-	7,0
	③	④	4,0	-	9,5
	⑤	⑥	1,5	-	-
ZN063-ZL_DG.V7P2	①	②	2,0	3,5	9,5
	③	④	2,5	-	10,0
	⑤	⑥	1,0	-	3,5
ZN063-ZL_GL.V7P3	①	②	4,5	5,5	16,5
	③	④	1,0	-	6,5
	⑤	⑥	0,5	-	1,5
ZN063-VD_6N.V7P4	①	②	3,0	0,5	9,5
	③	④	1,0	-	3,0
	⑤	⑥	1,5	-	3,5
ZN063-SD_4I.V7P1	①	②	1,0	1,0	4,5
	③	④	1,0	-	4,5
	⑤	⑥	1,0	-	3,5
ZN063-6E_4M.V7P1	①	②	1,5	2,0	6,5
	③	④	1,5	-	6,0
	⑤	⑥	1,0	-	4,5
ZN063-AD_4I.V7P1	①	②	1,0	-	3,0
	③	④	1,0	-	2,5
	⑤	⑥	1,0	-	3,0
ZN080-ZL_DG.V5P4	①	②	4,5	8,5	19,5
	③	④	3,5	-	13,5
	⑤	⑥	2,5	-	7,5
ZN080-ZL_GG.V7P3	①	②	4,5	7,0	18,0
	③	④	3,0	-	10,0
	⑤	⑥	1,0	-	1,5
ZN080-ZL_GL.V7P3	①	②	4,5	6,0	18,0
	③	④	3,0	-	8,5
	⑤	⑥	1,5	-	2,0
ZN080-SD_6N.V7P2	①	②	4,5	4,0	15,5
	③	④	2,5	-	11,5
	⑤	⑥	-	-	-
ZN080-AD_6N.V7P2	①	②	3,5	6,5	16,0
	③	④	3,0	-	11,5
	⑤	⑥	-	-	-
ZN080-ND_6K.V7P2	①	②	5,5	2,5	17,0
	③	④	1,0	-	8,0
	⑤	⑥	0,5	-	3,5
ZN091-ZL_DL.V5P1	①	②	2,1	2,2	8,0
	③	④	1,5	-	5,1
	⑤	⑥	1,0	-	2,1

* Comparison at identical speed/ ** identical air flow - using AC motors with Fcontrol

Information
Low pressure
High pressure
System components
Control technology
Appendix

Optimized sound emission with ZPlus+

Acoustic directivity = reduced centrifugal sound emission

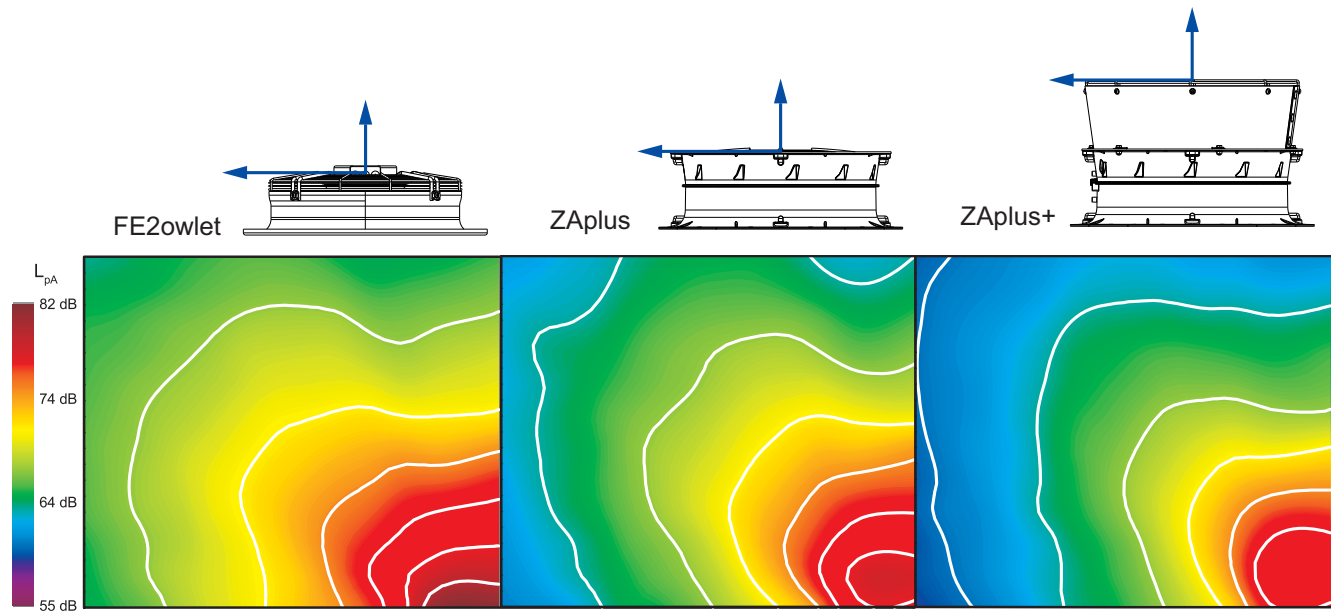

Sound emission with ZPlus mainly vertical. Lower noise for your neighbour



Backdraft fan shutter

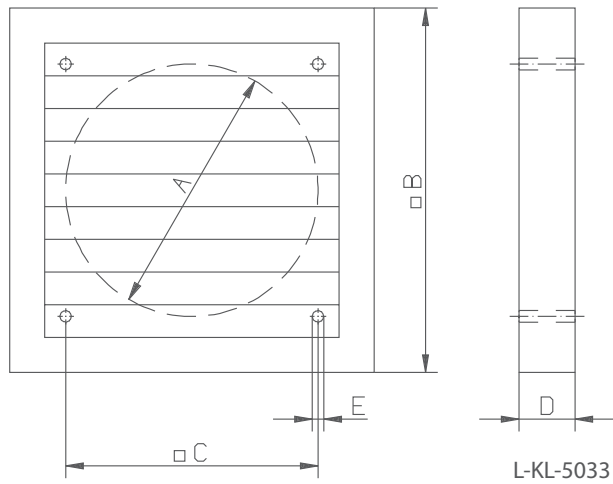

Description

Made of shock-proof and UV-resistant plastic
Colour: light grey.
Package includes mounting fixtures.
Larger shutters available on request.

Backdraft fan shutter						
Article no.	Type	A mm	B mm	C mm	D mm	E mm
00234330	SVK315	310	344	276	26	5
00234340	SVK350	360	394	310	26	5
00234350	SVK400	420	457	365	26	5
00234360	SVK450	460	499	395	31	5
00234370	SVK500	510	544	440	31	5
00234380	SVK560	565	605	533	31	5
00244980	SVK630	656	696	626	31	5
00236390	SVK710	720	760	692	43	5
00264387	SVK800	800	840	772	43	5
00264388	SVK1000	1000	1040	972	43	5

Information

Low pressure

High pressure

System components

Control technology

Appendix

Chimney installation kit design T

For vent chimneys

Description

Operational area: For installation in vent chimneys

Applications: Chimney installation

Diameter: See table

See assembly instructions L-BAL-015 and L-BAL-F053 for installation

Stainless steel

All fastening elements are made from stainless steel and can be delivered as an installation kit.

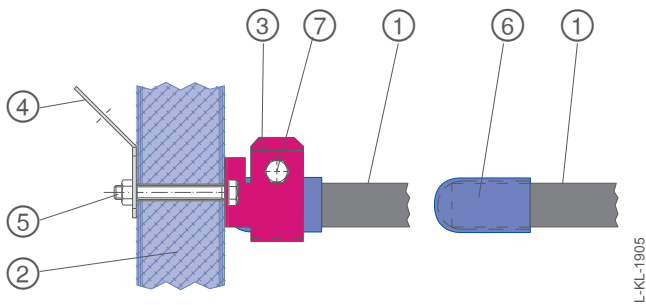

L-KL-1905

- ① Fan support arm
- ② Chimney wall
- ③ Fixing bracket (x 4)
- ④ Retaining bracket (x 4)
- ⑤ Screw (x 8 M8x70 DIN EN 24014), nut (x 8 M8 DIN EN ISO 10511 self-locking) and washer (x 8 A8.4 DIN EN ISO 7089)
- ⑥ Protective cap
- ⑦ Screw (x 4 M8x25 or M8x30 DIN EN 24014), nut (x 4 M8 DIN EN ISO 10511 self-locking) and washer (x 4 A8.4 DIN EN ISO 7089)

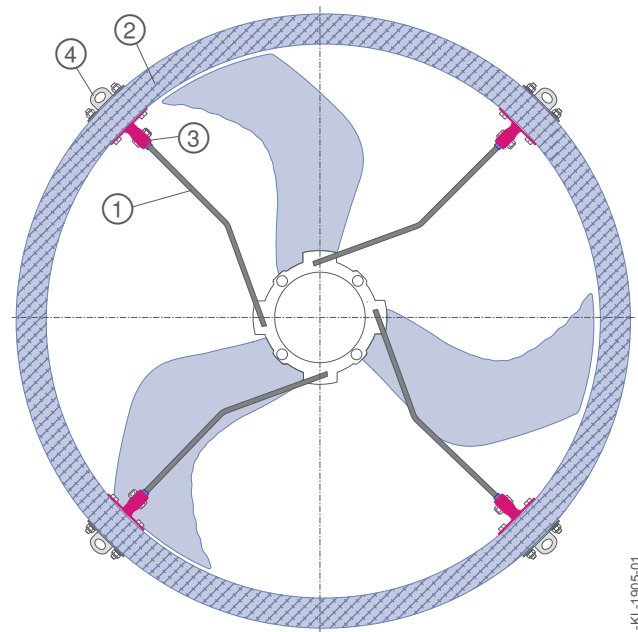

L-KL-1905-01

Synthetic material

The fixing brackets, made from impact-resistant plastic (included in scope of delivery) are designed to be flexible, thus enabling the fan support arm to clip in and allowing for adjustment to various chimney sizes according to the table.

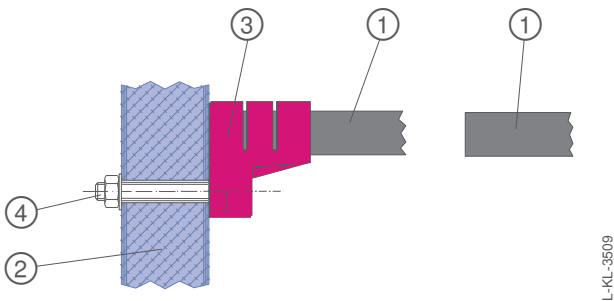

L-KL-3509

- ① Fan support arm
- ② Chimney wall
- ③ Fixing bracket (x 4)
- ④ Screw (x 8 M8x70 DIN EN 24014), nut (x 8 M8 DIN EN ISO 10511 self-locking) and washer (x 8 A8.4 DIN EN ISO 7089)

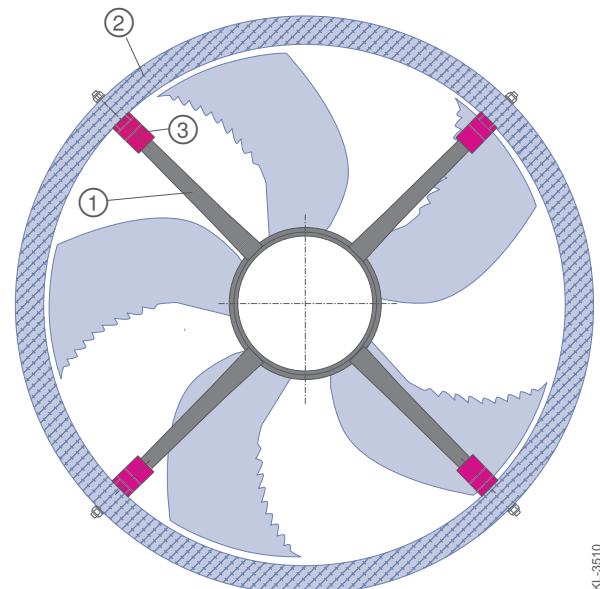

L-KL-3510



Chimney installation kit						
Motor	Type	Article no.	Fixing bracket material	Chimney diameter		Blade diameter mm
				Minimum mm	Maximum mm	
4	FC040	inclusive	Synthetic material	404	420	396
	FC045	inclusive	Synthetic material	460	470	447
	FC050	inclusive	Synthetic material	510	520	497
	FF056	inclusive	Synthetic material	570	580	553
	FF063	inclusive	Synthetic material	640	650	627
6	FC063	00370979	Stainless steel	640	660	627
	FC071	00370979	Stainless steel	725	745	703
	FF071	00370979	Stainless steel	725	745	703
	FF080	00370979	Stainless steel	815	835	788
	FF091	00370979	Stainless steel	915	935	905
7	FC091	00372782	Stainless steel	915	935	905
	FN125	00372782	Stainless steel	1265	1285	1248
D	FF050	inclusive	Synthetic material	510	520	497
	FF056	inclusive	Synthetic material	570	580	553
	FF063	inclusive	Synthetic material	640	650	627
	FF071	00370979	Stainless steel	725	745	703
	FF080	00370979	Stainless steel	815	835	788
	FF091	00370979	Stainless steel	915	935	905
	FN040	inclusive	Synthetic material	404	420	396
	FN045	inclusive	Synthetic material	460	470	447
G	FN063	00372782	Stainless steel	640	660	627
	FN071	00372782	Stainless steel	725	745	703
	FN080	00372782	Stainless steel	815	835	788
	FN091	00372782	Stainless steel	915	935	905
	FN125	00372782	Stainless steel	1265	1285	1248

Information

Low pressure

High pressure

System components

Control technology

Appendix



Control technology

Control technology

Overview	Page 128
Climate control module UNIcon	Page 130
1~ Fcontrol as climate control module	Page 132
1~ Fcontrol as a temperature controller	Page 134
1~ Fcontrol as speed controller	Page 136
1~ Acontrol as climate control module	Page 138
1~ Acontrol as a temperature controller	Page 140
1~ Acontrol as a simple temperature controller	Page 142
3~ Fcontrol, universal device with display	Page 144
3~ Fcontrol Basic 5-step	Page 146
3~ Fcontrol Basic	Page 148
3~ Dcontrol as speed controller	Page 150
ALARMcon for temperature monitoring	Page 152
Motor protection units	Page 154
Main switch with bypass function	Page 156
Main switch for EC-fans Zenec	Page 158
Temperature sensors	Page 160
Combined sensor humidity - temperature	Page 162

Information

Low pressure

High pressure

System components

Control technology

Appendix

Controllers for agriculture

ZIEHL-ABEGG is the only fan manufacturer that develops processes for changing fan speed and produce the corresponding controllers. ZIEHL-ABEGG uses a range of technologies here, forming a comprehensive product range:

- Voltage controllers
- Frequency inverters
- EC technology

Customer benefits stem not from stand-alone solutions in a special application. It is far more the criteria related to a system which are to be considered and which therefore lead to the best result.

Our products are used in countless machines and systems around the world. Manufacturers who install our products in your systems, together with ZIEHL-ABEGG sales staff, will help you find the best solution for your requirements.

Control engineering for agriculture

Animal welfare and cost-effective keeping of livestock are paramount. One requirement here is perfect animal housing climate. ZIEHL-ABEGG control engineering products have been used in agriculture for decades, impressing with their outstanding quality. Controlling the speed of the fans in a way that both meets requirements and saves energy is a major focus here. Just as important is the control of both heating and ventilation shutters. Compact controllers, tailored to real needs, are here to address these issues.

UNIcon climate control module

With comprehensive features for perfect air conditioning in livestock farming. The direct selection keys on the front of the device make operation simple and intuitive.

The control module offers multiple outputs for controlling high-efficiency ECblue fans. Frequency inverters, voltage controllers or other components such as shutters, heaters, etc. can also be controlled.



Fcontrol – frequency inverter as an climate control module

Energy-saving frequency inverter technology, combined with a range of functions for optimum air conditioning in livestock farming.

The power control for the fans and the air-con control module functions are combined in a single device.

These special Fcontrol are connected to 1~ 230 V and control the speed of 1~ AC fans.



Fcontrol frequency inverters generally have an integrated all-pole sinefilter, shielded motor wires are not required and fans or motors do not need to be specially compatible for frequency-inverted operation.

Energy-saving Fcontrol frequency inverters are available in various different versions, tailored to your application. 1~ and 3~ frequency inverters are generally available. For example, versions with simple temperature control function.

Frequency inverters with integrated 5-stage switches are particularly simple and effective, representing the perfect replacement for transformer-induced controllers. The desired ventilation level is simply set manually.

Frequency inverters that are set as universal speed controllers receive the setting signal for controlling the fans from a higher-level unit, such as a ZIEHL-ABEGG UNIcon climate control module.



Information

Low pressure

High pressure

System components

Control technology

Appendix

Voltage controllers

Voltage controllers are a popular and cost-effective alternative for speed control in fans.

ZIEHL-ABEGG offers a comprehensive range of voltage controllers for agriculture.

If voltage controllers need to be replaced in older systems, this can be also be achieved very easily using the energy-saving Fcontrol frequency inverters. Existing wires and fans can continue to be used in such a replacement.



Climate control module

UNIcon



UNIcon climate control module with a range of functions for perfect air conditioning in livestock farming.

The integrated multifunction display and direct selection keys enable simple and intuitive operation. An adjustable growth curve is integrated.

The devices can be used for independent control in individual cots or in animal housings with central extraction. Up to 32 devices can be networked via MODBUS-RTU. The alarm device ALARMcon can also be incorporated. Two temperature sensors can be attached, e.g. for controlling the cot and/or outdoor temperature (one TFR temperature sensor is included in the scope of delivery).

When devices are networked, the outdoor temperature can be transferred to other devices.

Three 0-10 V outputs are integrated, which can be used to control ECblue and ETAvent EC fans or frequency inverters. Three relays are integrated. Many components, such as ventilation shutters, heaters, heat exchangers, etc., can be controlled either via 0-10 V or via relay. It is also possible to control fans in a group.

Connection diagram

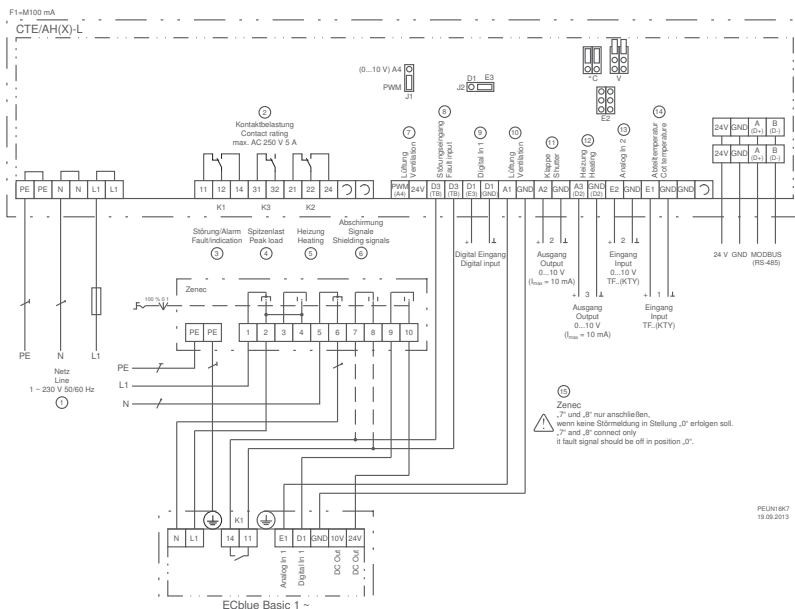

- ① Line 1~ 230 V, 50/60 Hz
- ② Contact load
- ③ Fault/Alarm
- ④ Peak load
- ⑤ Heating
- ⑥ Shielding signals
- ⑦ Ventilation
- ⑧ Fault input
- ⑨ Digital input
- ⑩ Ventilation
- ⑪ Shutter
- ⑫ Heating
- ⑬ Input
- ⑭ Cot temperature
- ⑮ Zenec ⑦ and ⑨ connect only if fault signal should be off in position "0"



Standard conformity

Interference emission according to EN 61000-6-3 (domestic)
Interference immunity according to EN 61000-6-2 (industrial)

Equipment / properties

Multifunction display with text display

Various menu languages can be set.

Simple and intuitive operation via 12 direct selection keys for the following functions:

- Temperature setpoint of ventilation
- Pband for ventilation
- Offset to setpoint for a throttle valve
- Offset to setpoint for heating 1
- Offset for heating 2
- Setpoint for minimum ventilation
- Setpoint for maximum ventilation
- Alarm value for maximum temperature
- Acknowledgement of alarm indication
- Button for growth curve
- Info button to return to overview display
- On and off button for the partition

2 analogue inputs for temperature sensors

E. g. for recording the partition temperature, outdoor temperature and/or controlling the heating temperature in a pig pen.

Input E2 can also be used to connect a humidity sensor (humidity control).

1 digital input

Programmable for external fault indication, connecting a measurement fan or additional input of a temperature sensor

3 analogue outputs 0 – 10 V

For power control, for example in ECblue and ETAvent EC fans, frequency inverters, voltage controllers, as well as for group control.

For controlling other devices, e.g. ventilation shutter, heating valve, heat exchanger

3 digital outputs (two changeover relays, one break)

E.g. fault indication/alarm, activation of peak load fan, activation of heating

RS485 interface

Up to 32 partition control devices can be networked. Option of incorporating the ZIEHL-ABEGG alarm device ALARMcon.

Set protection/memory for settings

Activate set protection to prevent unauthorised access, save and restore settings.

UNIcon climate control module

1~ 230V 50/60Hz

Type	Article no.	Max. line fuse	Max. heat dissipation	Minimum ambient temperature	Maximum ambient temperature	Protection class	Weight	Dimensions (W x H x D)
		A	W	°C	°C		kg	mm
CTE/AH-L	320036	10	7	0	55	IP54	1.20	223 x 200 x 115

Frequency inverters

1~ Fcontrol as climate control module



1~ frequency inverter Fcontrol, for controlling 1~ AC fans. The fans are supplied with a sinusoidal output voltage by the integrated sinefilter, which is comparable with the normal supply network. Frequency inverter-typical measures such as shielded motor cables are not necessary. The fan runs extremely efficiently, gently and reliably. Frequency inverter with comprehensive functions for optimum air conditioning in livestock farming. The integrated multifunction display and direct selection keys enable simple and intuitive operation. An adjustable growth curve is integrated. The devices can be used for independent control in individual cots or in animal housings with central extraction. Up to 32 devices can be networked via MODBUSRTU. The alarm device ALARMcon can also be incorporated. Two temperature sensors can be attached, e.g. for the outdoor temperature and cot temperature (one TFR temperature sensor is included in the scope of delivery). When devices are networked, the outdoor temperature can be transferred to other devices. Three 0-10 V outputs are integrated. Three relays are integrated. Many components, such as ventilation shutters, heating, heat exchangers, etc., can be controlled either via 0-10 V or via relay. It is possible to control fans in a group.

Connection diagram

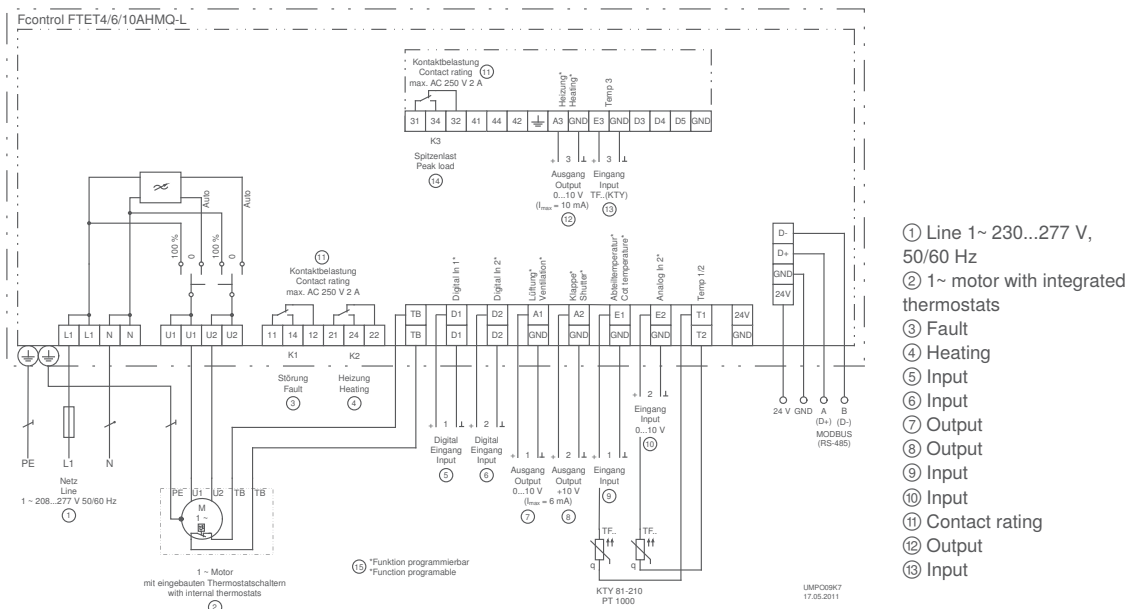

Standard conformity

Interference emission according to EN 61000-6-3 (domestic)
Interference immunity according to EN 61000-6-2 (industrial)

Equipment / properties

Integrated, all-pole effective sine filter

Phase to phase and phase to protective earth. Thus sinusoidal output voltage. Frequency inverter-typical measures such as shielded motor cables are not necessary.

Integrated PFC (Power Factor Controller)

Active power factor adaptation for sinusoidal current consumption. Therefore low line feedback.

Integrated main switch with bypass function

Switch positions: Auto (for standard operation), 0 and 100 % (100 % means the internal device electronics are bypassed and the line voltage switched to the output).

Multifunction display with text display

Various menu languages can be set.

Simple and intuitive operation via 12 direct selection keys for the following functions:

- Temperature setpoint of ventilation
- Pband for ventilation
- Offset to setpoint for a throttle valve
- Offset to setpoint for heating 1
- Offset to for heating 2
- Setpoint for minimum ventilation
- Setpoint for maximum ventilation
- Alarm value for maximum temperature
- Acknowledgement of alarm indication
- Button for growth curve
- Info button to return to overview display
- On and off button for the cot

2 analogue inputs for temperature sensors

E. g. for recording the cot temperature or outdoor temperature. The user can use input E2 either for individually controlling a ventilation shutter, for example, or to heat a pig pen (separate control circuit). Input E2 can also be used to connect a humidity sensor (humidity control).

1 digital input

Programmable for external fault indication, connecting a measurement fan or additional input of a temperature sensor

3 analogue outputs 0 – 10 V

For controlling additional power elements. Also for group control. Control of other devices, e.g. ventilation shutter, heating valve, heat exchanger, etc.

3 digital outputs (two changeover relays, one break)

E.g. fault indication/alarm, activation of peak load fan, activation of heating

RS485 interface

Up to 32 partition control devices can be networked. Option of incorporating the ZIEHL-ABEGG alarm device ALARMcon.

Set protection/memory for settings

Activate set protection to prevent unauthorised access, save and restore settings.

Information

Low pressure

High pressure

System components

Control technology

Appendix

Fcontrol as climate control module											
1~ 208...277V 50/60Hz											
Type	Article no.	Rated voltage	Rated current	Rated temperature	Max. line fuse	Max. heat dissipation	Minimum ambient temperature	Maximum ambient temperature	Protection class	Weight	Dimensions (W x H x D)
		V	A	°C	A	W	°C	°C		kg	mm
FTET4AHMQ-L	308201	230	4	35	6	65	0	55	IP54	3.50	240 x 284 x 132
FTET6AHMQ-L	308202		6	40	10	103	0	55		5.80	250 x 302 x 212
FTET10AHMQ-L	308203		10	50	16	187	0	55		6.90	250 x 302 x 212

Devices with a rated temperature below 55 °C can be used up to 55 °C with a reduction in performance.



Frequency inverters

1~ Fcontrol as a temperature controller



1~ frequency inverter Fcontrol, for controlling 1~ AC fans.
 The fans are supplied with a sinusoidal output voltage by the integrated sinefilter, which is comparable to the normal supply network. Frequency inverter-typical measures such as shielded motor cables are not necessary. The fans run extremely efficiently, gently and reliably.
 Thanks to the integrated inputs and outputs, the devices are well-suited for air conditioning in livestock farming, for example independent control of individual cots.
 Two temperature sensors can be attached, e.g. for controlling the cot and outdoor temperature (one TFR temperature sensor is included in the scope of delivery). Two 0-10 V outputs and two relays are integrated. Components such as ventilation shutters or heating can be controlled either via 0-10 V or via relay.

Connection diagram

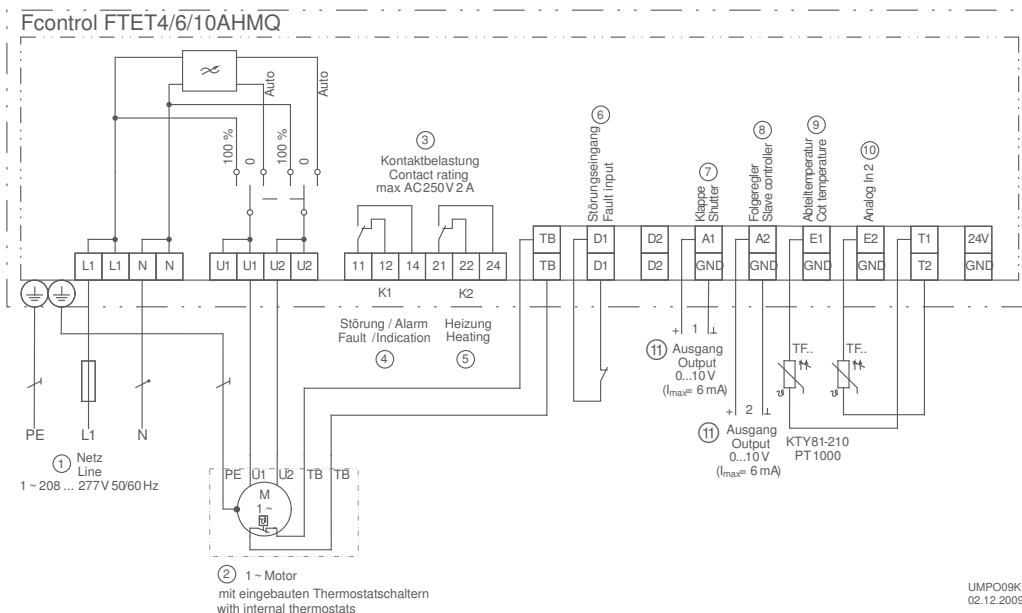

- ① Line
- ② 1~ Motor with integrated thermostats
- ③ Contact rating
- ④ Fault/Alarm
- ⑤ Heating
- ⑥ Fault input
- ⑦ Shutter
- ⑧ Slave controller
- ⑨ Compartment temperature
- ⑩ Analogue In 2
- ⑪ Output

Standard conformity

Interference emission according to EN 61000-6-3 (domestic)
Interference immunity according to EN 61000-6-2 (industrial)

Equipment / properties

Integrated, all-pole effective sine filter

Phase to phase and phase to protective earth. Thus sinusoidal output voltage. Frequency inverter-typical measures such as shielded motor cables are not necessary.

Integrated PFC (Power Factor Controller)

Active power factor adaptation for sinusoidal current consumption. Therefore low line feedback.

Integrated main switch with bypass function

Switch positions: Auto (for standard operation), 0 and 100 % (100 % means that the internal device electronics are bypassed and the line voltage switched to the output).

Multifunction display with text display

Various menu languages can be set.

Simple to operate

- Setpoint range 0 – 40 °C
- Minimum speed setting
- Maximum speed limitation
- Notification in the event that measured temperature values exceed or fall short of limits.
- Second control circuit with separate settings for 0 – 10 V output, e.g. activation of a ventilation shutter, etc.
- Relay K2 can be adjusted separately, e.g. to activate heating.

2 analogue inputs for temperature sensors

E. g. for recording the cot temperature or outdoor temperature. The user can use input E2 either for individually controlling a ventilation shutter, for example, or to heat a pig pen (separate control circuit).

1 digital input

Connection to an external fault indication

2 analogue outputs 0 – 10 V

Control of other devices, e.g. ventilation shutter, heating valve, heat exchanger, etc.

2 digital outputs (two changeover relays, one break)

E.g. fault indication/alarm, activate heating

Integrated motor protection function

Option to connect a thermostat "TB"

Set protection/settings memory

Activate set protection to prevent unauthorised access, save and restore settings.

Fcontrol as a temperature controller											
1~ 208...277V 50/60Hz											
Type	Article no.	Rated voltage	Rated current	Rated temperature	Max. line fuse	Max. heat dissipation	Minimum ambient temperature	Maximum ambient temperature	Protection class	Weight	Dimensions (W x H x D)
		V	A	°C	A	W	°C	°C		kg	mm
FTET4AHMQ	308131	230	4	35	6	65	0	55	IP54	3.40	240 x 284 x 132
FTET6AHMQ	308132		6	40	10	103	0	55		5.70	250 x 302 x 212
FTET10AHMQ	308133		10	50	16	187	0	55		6.80	250 x 302 x 212

Devices with a rated temperature below 55 °C can be used up to 55 °C with a reduction in performance.

Frequency inverters

1~ Fcontrol as speed controller



1~ frequency inverter Fcontrol, for controlling 1~ AC fans.
The fans are supplied with a sinusoidal output voltage by the integrated sinefilter, which is comparable with the normal supply network. Frequency inverter-typical measures such as shielded motor cables are not necessary. The fans run extremely efficiently, gently and reliably.
The devices are designed as speed controllers and can be used universally. This means that the rotational speed can be specified via a higher-level control, e.g. using a ZIEHL-ABEGG climate control module from the UNIcon range. Motors or fans can also be operated at set speeds or in a 2-step operation. Designs with integrated bypass main switch (switch positions auto – 0 – 100%) can also be delivered.

Connection diagram

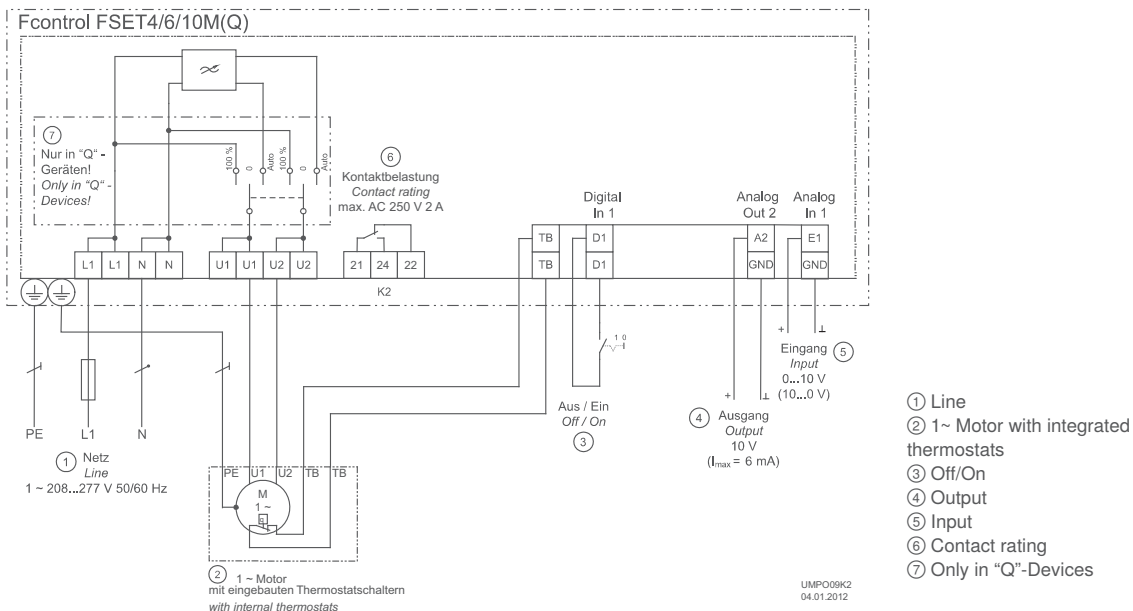

Standard conformity

Interference emission according to EN 61000-6-3 (domestic)
Interference immunity according to EN 61000-6-2 (industrial)

Equipment / properties

Integrated, all-pole effective sine filter

Phase to phase and phase to protective earth. Thus sinusoidal output voltage. Frequency inverter-typical measures such as shielded motor cables are not necessary.

Integrated PFC (Power Factor Controller)

Active power factor adaptation for sinusoidal current consumption. Therefore low line feedback.

Optional designs with "Q":

Integrated main switch with bypass function

Switch positions: Auto (for standard operation), 0 and 100 % (100 % means the internal device electronics are bypassed and the line voltage switched to the output).

1 analogue input for speed specification

Input E1 for 0 – 10 V setting signal or 10 – 0 V, depending on device version.

1 digital input

Input D1 for enabling (stand-by), also for external reset (following motor fault)

1 output 10 V

For connecting an external potentiometer, for manual rotational speed specification.

1 digital output (changeover relay)

Fault indication output

Integrated motor protection function

Option of connecting a thermostat "TB"

Accessories, see system components

Separate bypass main switch

Fcontrol as speed controller										
1~ 208...277V 50/60Hz										
Input	Type	Article no.	Rated voltage	Rated current	Rated temperature	Max. line fuse	Max. heat dissipation	Protection class	Weight	Dimensions (W x H x D)
			V	A	°C	A	W		kg	mm
0-10 V	FSET4M	308128	230	4	35	6	65	IP54	3.20	240 x 284 x 115
	FSET6M	308156		6	40	10	103		5.50	250 x 302 x 195.5
	FSET10M	308130		10	50	16	187		6.60	250 x 302 x 195.5
	FSET4MQ	308154		4	35	6	65		3.30	240 x 284 x 132
	FSET6MQ	308155		6	40	10	103		5.60	250 x 302 x 212
	FSET10MQ	308187		10	50	16	187		6.70	250 x 302 x 212
10-0 V	FSET4M	308158	230	4	35	6	65	IP54	3.20	240 x 284 x 115
	FSET6M	308159		6	40	10	103		5.50	250 x 302 x 195.5
	FSET10M	308160		10	50	16	187		6.60	250 x 302 x 195.5
	FSET4MQ	308248		4	35	6	65		3.30	240 x 284 x 132
	FSET6MQ	308249		6	40	10	103		5.60	250 x 302 x 212
	FSET10MQ	308250		10	50	16	187		6.70	250 x 302 x 212

Devices with a rated temperature below 55 °C can be used up to 55 °C with a reduction in performance.

Voltage controller

1~ Acontrol as climate control module



1~ voltage controller Acontrol for controlling voltage-variable 1~ AC fans. With a range of functions for perfect air conditioning in livestock farming. The integrated multifunction display and direct selection keys enable simple and intuitive operation. An adjustable growth curve is integrated. The devices can be used for independent control in individual cots or in animal housings with central extraction. Up to 32 devices can be networked via MODBUS-RTU. The alarm device ALARMcon can also be integrated. Two temperature sensors can be attached, for example for the outdoor temperature and cot temperature (one TFR temperature sensor is included in the scope of delivery). When devices are networked, the outdoor temperature can be transferred to other devices. Three 0-10 V outputs and three relays are integrated. Many components, such as ventilation shutters, heating, heat exchangers, etc., can be controlled either via 0-10 V or via relay. It is possible to control fans in a group.

Connection diagram

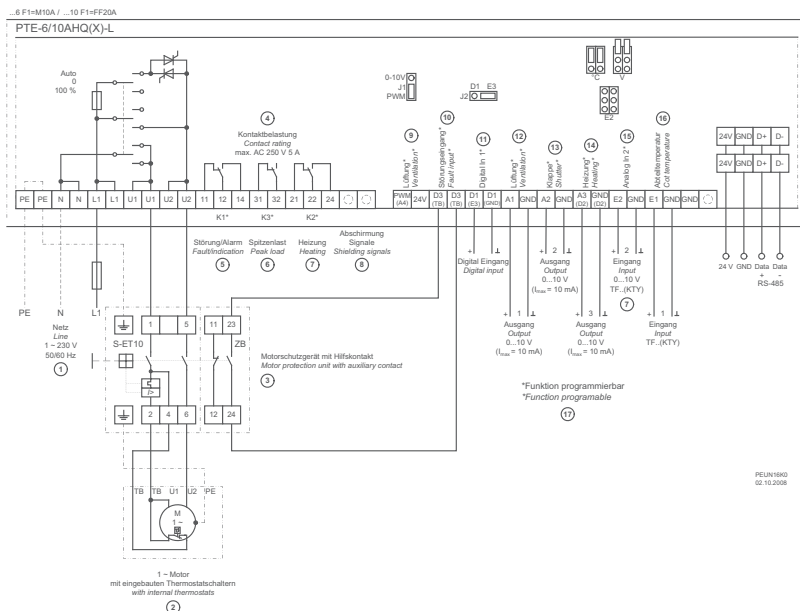

- ① Line 1~ 230 V 50/60 Hz
- ② 1~ motor with integrated thermostats
- ③ Motor protection unit with auxiliary contact
- ④ Max. contact rating AC 250 V 5 A
- ⑤ Fault/Alarm
- ⑥ Peak load
- ⑦ Heating
- ⑧ Signal shielding
- ⑨ Ventilation*
- ⑩ Fault input*
- ⑪ Digital In1*
- ⑫ Ventilation*
- ⑬ Shutter*
- ⑭ Heating*
- ⑮ Analogue In 2*
- ⑯ Cot temperature*
- ⑰ * Function programmable

Standard conformity

Interference emission according to EN 61000-6-3 (domestic)
Interference immunity according to EN 61000-6-2 (industrial)

Equipment / properties

Integrated main switch with bypass function

Switch positions: Auto (for standard operation), 0 and 100 % (100 % means the internal device electronics are bypassed and the line voltage switched to the output).

Multifunction display with text display

Various menu languages can be set.

Simple and intuitive operation via 12 direct selection keys for the following functions:

- Temperature setpoint of ventilation
- Pband for ventilation
- Offset to setpoint for a throttle valve
- Offset to setpoint for heating 1
- Offset for heating 2
- Setpoint for minimum ventilation
- Setpoint for maximum ventilation
- Alarm value for maximum temperature
- Acknowledgement of alarm indication
- Button for growth curve
- Info button to return to overview display
- On and off button for the cot

2 analogue inputs for temperature sensors

E. g. for recording the cot temperature, outdoor temperature and/or for controlling heating temperature in a pig pen.
Input E2 can also be used to connect a humidity sensor (humidity control).

1 digital input

Programmable for external fault indication, connecting a measurement fan or additional input of a temperature sensor

3 analogue outputs 0 – 10 V

For controlling additional power elements. Also for group control.
Control of other devices, e.g. ventilation shutter, heating valve, heat exchanger

3 digital outputs (two changeover relays, one break)

E.g. fault indication/alarm, activation of peak load fan, activation of heating

RS485 interface

Up to 32 partition control devices can be networked. Option of incorporating the ZIEHL-ABEGG alarm device ALARMcon.

Set protection/memory for settings

Activate set protection to prevent unauthorised access, save and restore settings.

Accessories, see system components

Motor protection units

Acontrol as climate control module										
1~ 230V 50/60Hz										
Type	Article no.	Rated current	Rated temperature	Max. line fuse	Max. heat dissipation	Minimum ambient temperature	Maximum ambient temperature	Protection class	Weight	Dimensions (W x H x D)
		A	°C	A	W	°C	°C		kg	mm
PTE-6AHQ-L	303616	6	45	10	20	0	55	IP54	1.50	223 x 200 x 131
PTE-10AHQ-L	303617	10	40	16	40	0	55		2.50	240 x 284 x 132

Devices with a rated temperature below 55 °C can be used up to 55 °C with a reduction in performance.

Voltage controller

1~ Acontrol as a temperature controller



1~ voltage controller Acontrol, for controlling voltage-variable 1~ AC fans. The integrated inputs and outputs make the devices perfectly suited for air conditioning in livestock farming and for automatic control of individual cots.

Two temperature sensors can be attached, for example for the outer temperature and cot temperature (one TFR temperature sensor is included in the scope of delivery).

Two 0-10 V outputs and two relays are integrated. Components such as ventilation shutters or heating can be controlled either via 0-10 V or via relay.

Connection diagram

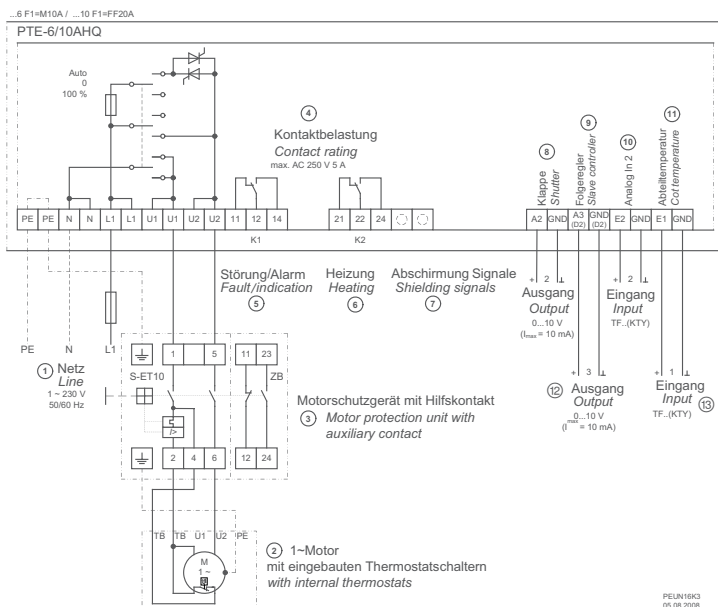

- ① Line
- ② 1~ Motor with integrated thermostats
- ③ Motor protection unit with auxiliary contact
- ④ Contact rating
- ⑤ Fault/Alarm
- ⑥ Heating
- ⑦ Shielding signals
- ⑧ Shutter
- ⑨ Slave controller
- ⑩ Analogue In 2
- ⑪ Compartment temperature
- ⑫ Output
- ⑬ Input

PEUN16K3
05.08.2008



Standard conformity

Interference emission according to EN 61000-6-3 (domestic)
Interference immunity according to EN 61000-6-2 (industrial)

Equipment / properties

Integrated main switch with bypass function

Switch positions: Auto (for standard operation), 0 and 100 % (100 % means that the internal device electronics are bypassed and the line voltage switched to the output).

Multifunction display with text display

Various menu languages can be set.

Simple to operate

- Setpoint range 0 – 40 °C
- Minimum speed setting, maximum speed limit
- Notification in the event that measured temperature values exceed or fall short of limits
- Second control circuit with separate settings for 0 – 10 V output, e.g. activation of a ventilation shutter, etc.
- Relay K2 can be adjusted separately, to activate heating, for example.

2 analogue inputs for temperature sensors

E. g. for measuring cot temperature
The input E2 can be used for individually controlling a ventilation shutter or heating (separate control circuit)

1 digital input

Connection to an external fault indication

2 analogue outputs 0 – 10 V

For activating other devices, e.g. ventilation shutter, heating, etc.

2 digital outputs (two changeover relays)

e.g. fault indication/alarm, activate heating

Set protection/settings memory

Activate set protection to prevent unauthorised access, save and restore settings

Accessories, see system components

Motor protection units

Acontrol as a temperature controller

1~ 230V 50/60Hz

Type	Article no.	Rated current	Rated temperature	Max. line fuse	Max. heat dissipation	Minimum ambient temperature	Maximum ambient temperature	Protection class	Weight	Dimensions (W x H x D)
		A	°C	A	W	°C	°C		kg	mm
PTE-6AHQ	303606	6	45	10	20	0	55	IP54	1.50	223 x 200 x 131
PTE-10AHQ	303607	10	40	16	40	0	55		2.50	240 x 284 x 132

Devices with a rated temperature below 55 °C can be used up to 55 °C with a reduction in performance.

Voltage controller

1~ Acontrol as a simple temperature controller



1~ voltage controller Acontrol for controlling voltage-variable 1~ AC fans. The device's simple design enables temperature control in an animal house. A dial is integrated in the front of the device for setting the nominal temperature. The dial features a light display for signalling the operating state. A TFR temperature sensor can be connected and is included in the scope of delivery. A 0-10 V output is integrated

Connection diagram

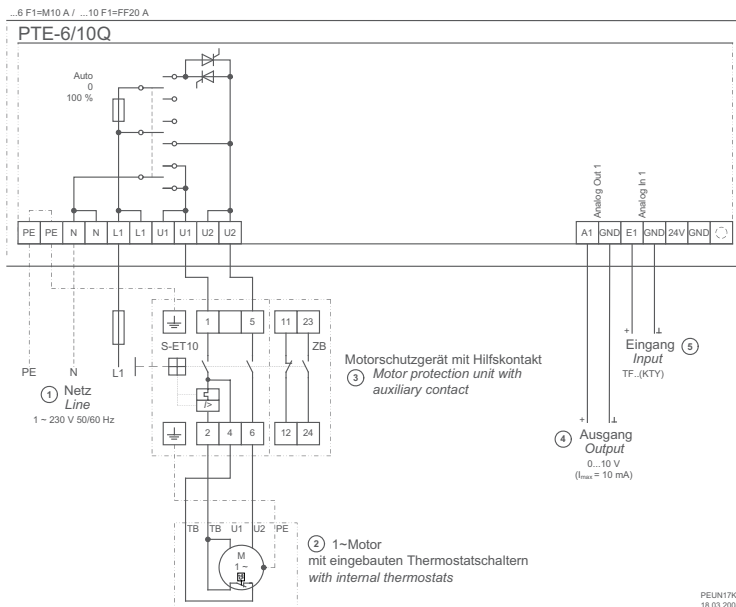

- ① Line
- ② 1~ Motor with integrated thermostats
- ③ Motor protection unit with auxiliary contact
- ④ Output
- ⑤ Input

PELN17K1
18.03.2008

Standard conformity

Interference emission according to EN 61000-6-3 (domestic)
Interference immunity according to EN 61000-6-2 (industrial)

Equipment / properties

Integrated main switch with bypass function

Switch positions: Auto (for standard operation), 0 and 100 % (100 % means that the internal device electronics are bypassed and the line voltage switched to the output). There is also the "manual" switch position. The dial can be used to manually set the desired fan speed.

Simple operation thanks to setpoint setting dial

- Setpoint range 0 – 40 °C
- Further settings are possible using internal potentiometers and dip-switch.

1 input for temperature sensor

Input E1: Connection for room thermistor (included in scope of delivery)

1 analogue output

Control, e.g. for slave controller

Accessories, see system components

Motor protection units

Acontrol as a simple temperature controller										
1~ 230V 50/60Hz										
Type	Article no.	Rated current	Rated temperature	Max. line fuse	Max. heat dissipation	Maximum ambient temperature	Minimum ambient temperature	Protection class	Weight	Dimensions (W x H x D)
		A	°C	A	W	°C	°C		kg	mm
PTE-6Q	303618	6	45	10	20	55	0	IP54	1.30	223 x 200 x 131
PTE-10Q	303619	10	40	16	40	55	0		2.30	240 x 284 x 132

Devices with a rated temperature below 55 °C can be used up to 55 °C with a reduction in performance.

Frequency inverters

3~ Fcontrol, universal controller with display



3~ frequency inverter Fcontrol, for controlling 3~ fans and motors. The fans/ motors are supplied with a sinusoidal output voltage by the integrated sinefilter which is comparable with the normal supply network. Frequency inverter-typical measures such as shielded motor cables are not necessary. The fans/ motors run extremely efficiently, gently and reliably.

Different operating modes are stored in the devices and can be selected. In livestock farming, frequency inverters are normally used as universal speed controllers or temperature controllers.

Use as speed controller:

The speed setting 0 – 10 V can be made by a higher-level control, e.g. using a ZIEHL-ABEGG climate control module from the UNIcon range. Fans/motors can also be operated with set speeds or in 2-step operation. Manual mode can also be set.

Use as temperature controller:

Temperature control with pre-set additional functions (heating, shutter, temperature monitoring)

Connection diagram

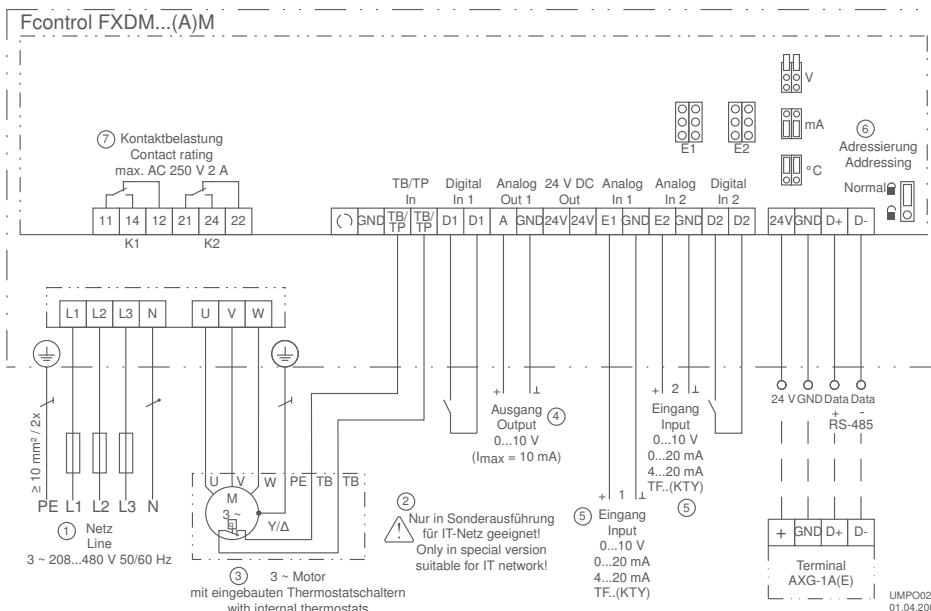

- ① Line
- ② Only in special version suitable for IT network!
- ③ Motor feeder cable
- ④ Output
- ⑤ Input
- ⑥ Addressing
- ⑦ Contact rating

Standard conformity

Interference emission according to EN 61000-6-3 (domestic)
Interference immunity according to EN 61000-6-2 (industrial)

Equipment / properties

Integrated, all-pole effective sine filter

Phase to phase and phase to protective earth. Thus sinusoidal output voltage. Frequency inverter-typical measures, such as shielded motor wires, are not required.

Multifunction display with text display

Various menu languages can be set.

Simple operation via operating modes

Typical operating modes can be selected, e.g. for air-conditioning, refrigeration or ventilation.

2 analogue inputs for setting signals or temperature sensors

Analogue input E1 and E2: Can be set either manually or using modes, e.g. 0 – 10 V, 0 – 20 mA, 4 – 20 mA. Option to connect temperature sensors.

2 digital inputs

Programmable, e.g. approval, switch between setpoint 1 or 2, switch between control or manual mode, etc.

1 analogue output

Programmable, e.g. 10 V constant voltage for connecting an external potentiometer, or with temperature control as output for controlling a ventilation shutter or heating.

2 digital outputs (two changeover relays)

E.g. fault indication/alarm, activation of heating

Integrated motor protection function

Option to connect "TB" thermostat

Set protection/settings memory

Activate set protection to prevent unauthorised access, save and restore settings.

Accessories, see system components

Separate bypass main switch

Fcontrol, universal controller with display

3~ 208...480V 50/60Hz

Type	Article no.	Rated voltage	Rated current	Rated temperature	Max. line fuse	Max. heat dissipation	Protection class	Weight	Dimensions (W x H x D)
		V	A	°C	A	W		kg	mm
FXDM2.5AM	308099	400	2,5	40	6	50	IP54	3.30	240 x 284 x 115
FXDM5AM	308138		5	50	10	100		7.20	250 x 302 x 195.5
FXDM8AM	308140		8	50	10	150		7.90	250 x 302 x 195.5
FXDM10AM	308142		10	55	16	210		8.20	250 x 302 x 195.5
FXDM14AM	308144		14	40	16	310		8.70	250 x 302 x 195.5
FXDM18AM	308174		18	40	20	400		9.10	250 x 302 x 195.5
FXDM22AM	308108		22	40	25	520		14.50	280 x 355 x 239
FXDM32AM	308009		32	50	35	700		29.60	386 x 525 x 283
FXDM40AM	308177		40	50	50	790		29.60	386 x 525 x 283
FXDM50AM	308183		50	50	63	910		32.80	386 x 525 x 283

Devices with a rated temperature below 55 °C can be used up to 55 °C with a reduction in performance.

Frequency inverters

3~ Fcontrol Basic 5-Step, Speed controller



3~ frequency inverter Fcontrol in "Basic" version with integrated 5-step switch for control of 3~ fans and motors. The fans/motors are supplied with a sinusoidal output voltage by the integrated sine filter which is comparable with the normal supply network. Frequency inverter typical measures such as shielded motor cables are not necessary. The fan/motor operation is very energy saving, gentle and reliable.

The devices in this version are speed controllers for manual setting of fan or motor speeds. These configurations are perfectly suited, for example, to replacing transformer control units with modern and energy-saving frequency inverters.

These products are very easy to operate. Installation is very simple.

Connection diagram

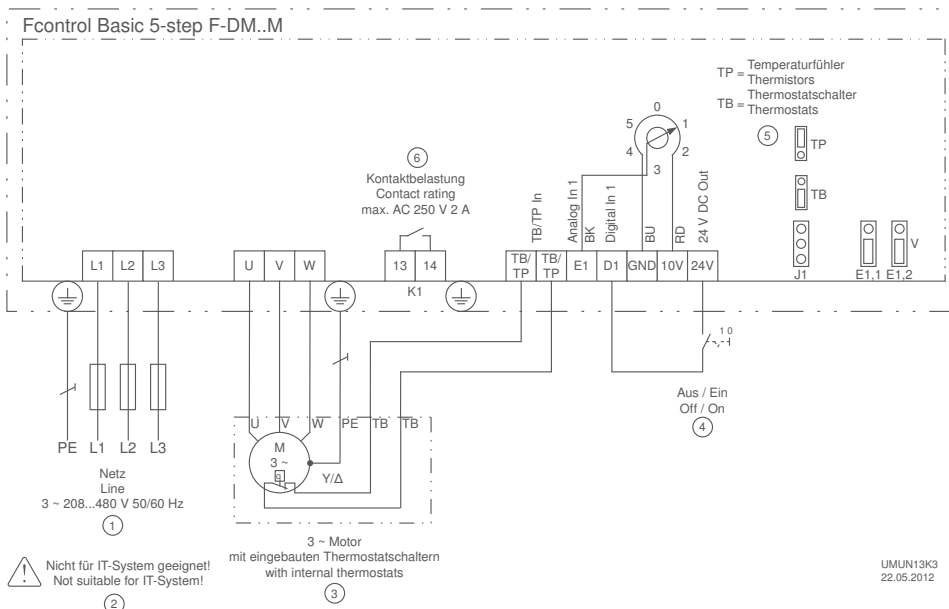

Standard conformity

Interference emission according to EN 61000-6-3 (domestic)
Interference immunity according to EN 61000-6-2 (industrial)

Equipment / properties

Integrated, all-pole effective sine filter

Phase to phase and phase to PE conductor. Thus sinusoidal output voltage. Frequency inverter typical measures such as shielded motor cables are not necessary.

Simple operation and setting

Desired speeds are set by the 5-step switch.

1 digital input

D1 – 24 V: Enable function On/Off

1 potential-free fault indication contact

The contact drops out in the event of a fault. Max. load 250 V, 2A.

Integrated motor protection function

Connection possibility for thermostat "TB" or thermistor "TP".

Fcontrol Basic 5-step									
3~ 208...480V 50/60Hz									
Type	Article no.	Rated voltage	Rated current	Rated temperature	Max. line fuse	Max. heat dissipation	Protection class	Weight	Dimensions (W x H x D)
		V	A	°C	A	W		kg	mm
F-DM2.5M	308255	400	2,5	40	6	50	IP54	2.80	240 x 284 x 132
F-DM5M	308256		5	55	10	90		5.50	250 x 302 x 212
F-DM8M	308257		8	40	10	140		6.40	250 x 302 x 212
F-DM10M	308258		10	55	16	200		6.90	250 x 302 x 212
F-DM16M	308304		16	40	20	360		7.10	250 x 302 x 212

Devices with a rated temperature below 55 °C can be used up to 55 °C with a reduction in performance.

Frequency inverters

3~ Fcontrol Basic, Speed controller with display



3~ frequency inverter Fcontrol in "Basic" version with integrated display for control of 3~ fans and motors. The fans/motors are supplied with a sinusoidal output voltage by the integrated sinefilter which is comparable with the normal supply network. Frequency inverter-typical measures such as shielded motor cables are not necessary. The fans/motors run extremely efficiently, gently and reliably.

The devices are designed as speed controllers and can be used universally. This means that the rotational speed can be specified via a higher-level control, e.g. using a ZIEHL-ABEGG climate control module from the UNIcon range. Motors or fans can also be operated at set speeds or in a 2-step operation.

Connection diagram

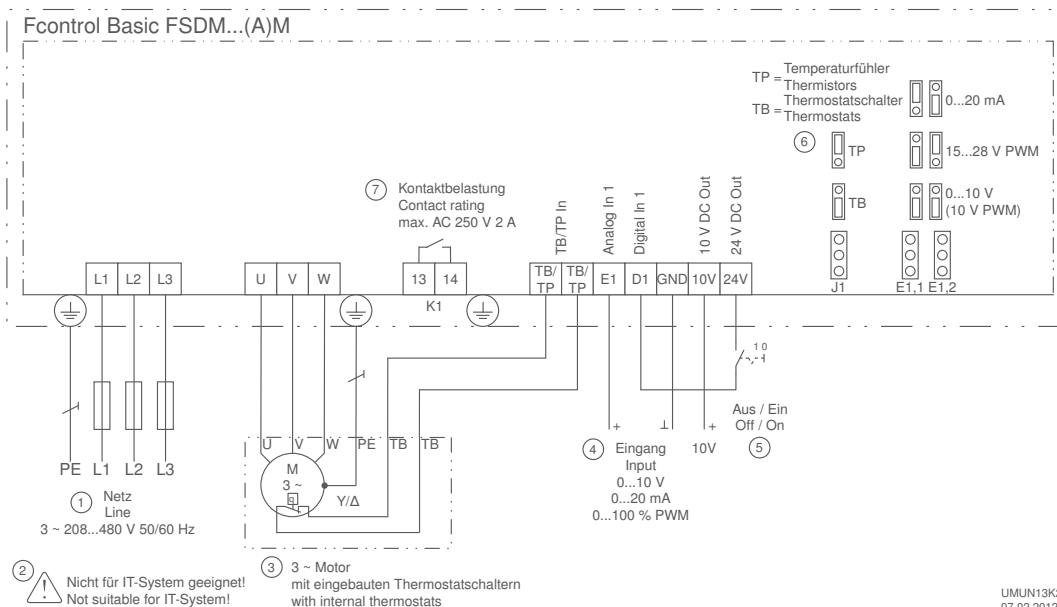

Standard conformity

Interference emission according to EN 61000-6-3 (domestic)
Interference immunity according to EN 61000-6-2 (industrial)

Equipment / properties

Integrated main switch with bypass function

Phase to phase and phase to protective earth. Thus sinusoidal output voltage. Frequency inverter-typical measures such as shielded motor wires are not required.

Multifunction display with text display

Various menu languages can be set.

Simple operation and setting

Setting of desired values: Speeds, fan level display, operating states, etc.

1 digital input

D1 – 24 V: Approval function on/off

1 digital input

Connection of an external fault indication.

1 potential-free fault indication contact

The contact drops in the event of a fault. Max. load 250 V 2A.

Integrated motor protection function

Connection option for thermostat "TB" or thermistor "TP".

Fcontrol Basic, Speed controller with display									
3~ 208...480V 50/60Hz									
Type	Article no.	Rated voltage	Rated current	Rated temperature	Max. line fuse	Max. heat dissipation	Protection class	Weight	Dimensions (W x H x D)
		V	A	°C	A	W		kg	mm
FSDM2.5AM	308252	400	2,5	40	6	50	IP54	2.90	240 x 284 x 115
FSDM5AM	308240		5	55	10	90		5.60	250 x 302 x 195.5
FSDM8AM	308241		8	40	10	140		6.50	250 x 302 x 195.5
FSDM10AM	308260		10	55	16	200		7.00	250 x 302 x 195.5
FSDM16AM	308303		16	40	20	360		7.20	250 x 302 x 195.5
FSDM22AM	308315		22	40	25	520		14.50	280 x 355 x 239
FSDM32AM	308317		32	50	35	700		29.60	386 x 525 x 283
FSDM40AM	308319		40	50	50	790		29.60	386 x 525 x 283
FSDM50AM	308321		50	50	50	63		910	32.80

Devices with a rated temperature below 55 °C can be used up to 55 °C with a reduction in performance.

Voltage controller

3~ Dcontrol as speed controller



3~ voltage controller Dcontrol for controlling voltage-variable 3~ fans. In livestock farming, frequency inverters are normally used as universal speed controllers.

The speed setting 0 – 10 V can be made by a higher-level control, e.g. using a ZIEHL-ABEGG climate control module from the UNIcon range. Motors or fans can also be operated at set speeds or in a 2-step operation.

Connection diagram

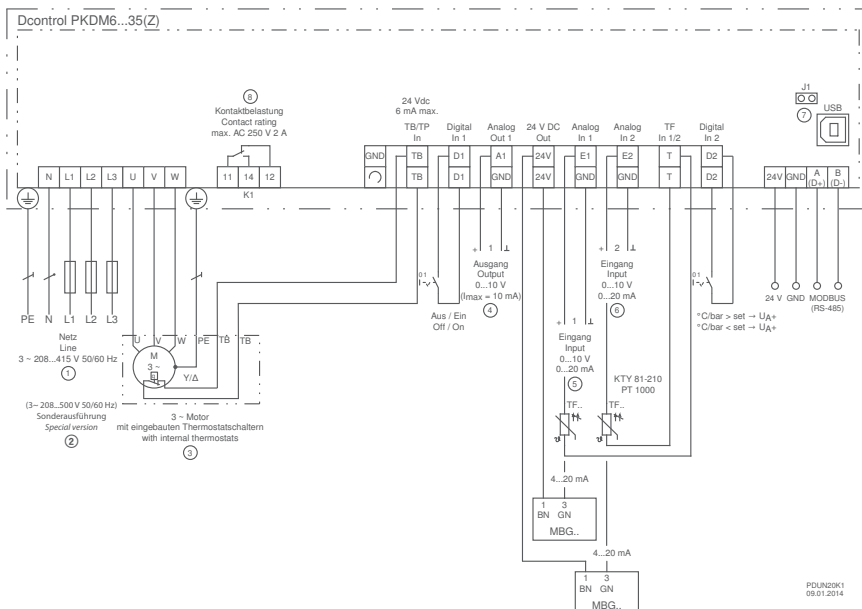

- ① Netz 3~ 208..415 V 50/60 Hz
- ② Special version UL 3~ 208...500 V 50/60 Hz
- ③ 3~ motor motor with built-inthermostats
- ④ Output
- ⑤ Input
- ⑥ Input
- ⑦ USB interface
- ⑧ Contact load

PELUNGSKI
09.01.2014

Standard conformity

Interference emission according to EN 61000-6-3 (domestic)
Interference immunity according to EN 61000-6-2 (industrial)

Equipment / properties

Analogue inputs for specification signal

Analogue input E1 and E2: For setting signal e.g. 0 – 10 V, 0 – 20 mA.

Digital inputs

D1 – D1: Approval function on/off

Analogue output

Programmable, e.g. 10 V constant voltage for connecting an external potentiometer or 0 – 10 V output proportional control.

Potential-free fault indication

The relay drops in the event of a fault. Max. load 250 V 2A.

Integrated motor protection function

Connection option for thermostat "TB" or thermistor "TP".

Dcontrol as speed controller											
3~ 208...415V 50/60Hz											
Type	Article no.	Rated voltage	Rated current	Rated temperature	Max. line fuse	Max. heat dissipation	Minimum ambient temperature	Maximum ambient temperature	Protection class	Weight	Dimensions (W x H x D)
		V	A	°C	A	W	°C	°C		kg	mm
PKDM6	304587	400	6	40	10	30	0	55	IP54	2.20	240 x 284 x 115
PKDM10	304588		10	45	16	50	0	55		2.70	240 x 284 x 115
PKDM12	304589		12	40	16	75	0	55		3.60	270 x 323 x 146
PKDM15	304590		15	40	20	100	0	55		4.90	270 x 323 x 146
PKDM20	304591		20	45	25	200	0	55		5.45	250 x 302 x 195.5
PKDM25	304592		25	45	35	270	0	55		11.05	280 x 355 x 239
PKDM35	304593		35	50	50	440	0	55		11.10	280 x 355 x 239
PKDM50	305563		50	40	63	170	0	55		19.50	386 x 525 x 283
PKDM80	305564		80	40	100	270	0	55		20.50	386 x 525 x 283

Devices with a rated temperature below 55 °C can be used up to 55 °C with a reduction in performance.

Dcontrol as speed controller											
3~ 415V 50/60Hz											
Type	Article no.	Line voltage	Rated current	Rated temperature	Max. line fuse	Max. heat dissipation	Minimum ambient temperature	Maximum ambient temperature	Protection class	Weight	Dimensions (W x H x D)
			A	°C	A	W	°C	°C		kg	mm
PKDT5	304555	415	5	40	10	25	0	55	IP54	2.92	240 x 284 x 115

Devices with a rated temperature below 55 °C can be used up to 55 °C with a reduction in performance.

Alarm device

ALARMcon for temperature monitoring



In order to ensure animal welfare, technical faults in the animal housing need to be detected before they present a danger to livestock.

The ZIEHL-ABEGG alarm device ALARMcon both monitors temperatures in the partitions and triggers an alarm when faults are indicated at the digital inputs of other devices.

We offer temperature sensor add-on modules for monitoring temperature. Together with the ZIEHL-ABEGG cot controllers, these make it possible to monitor up to 32 animal housing cots.

Depending on requirements, different "networks" can be created from the cot controllers, the temperature sensor add-on modules and the ALARMcon for monitoring (networking via MODBUS RTU). Temperature sensors from the ZIEHL-ABEGG cot devices can be assessed by this device's MODBUS. Separate temperature sensors can also be incorporated using the ZTG8-L add-on module.

A battery integrated in the ALARMcon ensures that the alarm can be triggered even in the event of a power cut. A flashlight and alarm horn can be connected for optical and acoustic alerting.

Connection diagram

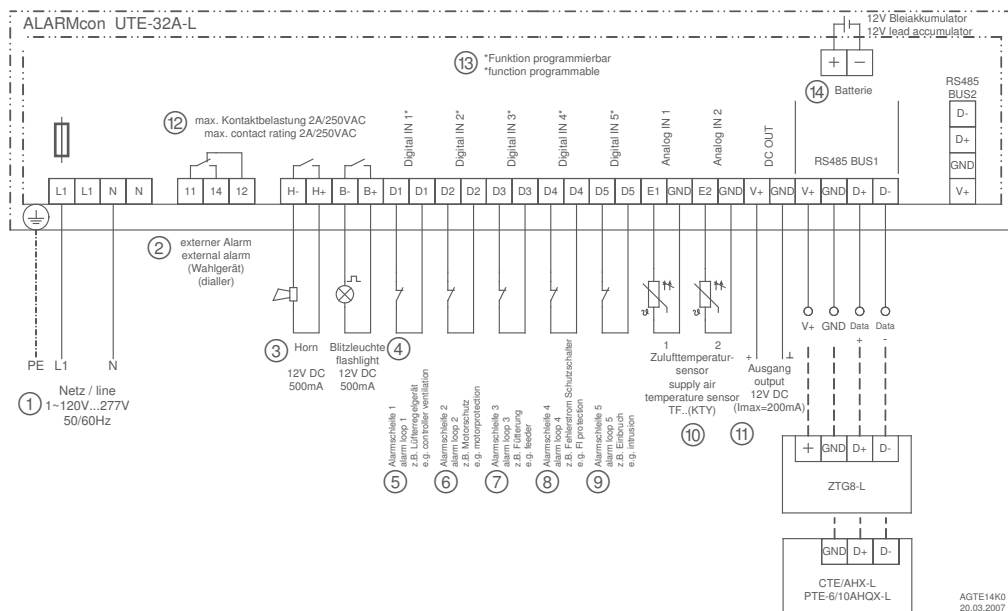

- ① Line 1~ 120 V...277 V
- ② External alarm
- ③ Horn
- ④ Flashlight
- ⑤ Alarm loop 1, e.g. controller ventilation
- ⑥ Alarm loop 2, e.g. motor protection
- ⑦ Alarm loop 3, e.g. feeder
- ⑧ Alarm loop 4, e.g. FI protection
- ⑨ Alarm loop 5, e.g. intrusion
- ⑩ Supply air temperature sensor
- ⑪ Output 12V DC
- ⑫ Max. contact rating 2 A 250 V AC
- ⑬ Input function programmable
- ⑭ Battery 12 v lead accumulator



Standard conformity

Interference emission according to EN 61000-6-3 (domestic)
Interference immunity according to EN 61000-6-1 (domestic)

Equipment / properties

2 analogue inputs

Analogue input E1 and E2: For connecting supply air temperature sensors (2 TFR sensors are included in the scope of delivery).

Digital inputs

D1 – D5: Inputs for alarm loops, for fault indications from other devices.

Potential-free relay

The relay drops in the event of a fault. On-site connection of a telephone dialling device.

ALARMcon for temperature monitoring						
Line	Type	Article no.	Protection class	Ambient temperature	Weight	Dimensions (W x H x D)
1~ 120...277V 50/60Hz	UTE-32A-L	326003	IP54	max. +40°C	kg 5.50	mm 270 x 323 x 146

ALARMcon for temperature monitoring						
Line voltage	Type	Article no.	Protection class	Ambient temperature	Weight	Dimensions (W x H x D)
24VDC	ZTG8-L	380043	IP54	max. +40°C	kg 0.50	mm 180 x 130 x 78
12VDC	DS-12L	00153985		0...+40°C	0.44	d130 x 150
12VDC	SG1670	349039			0.22	175 x 110 x 80

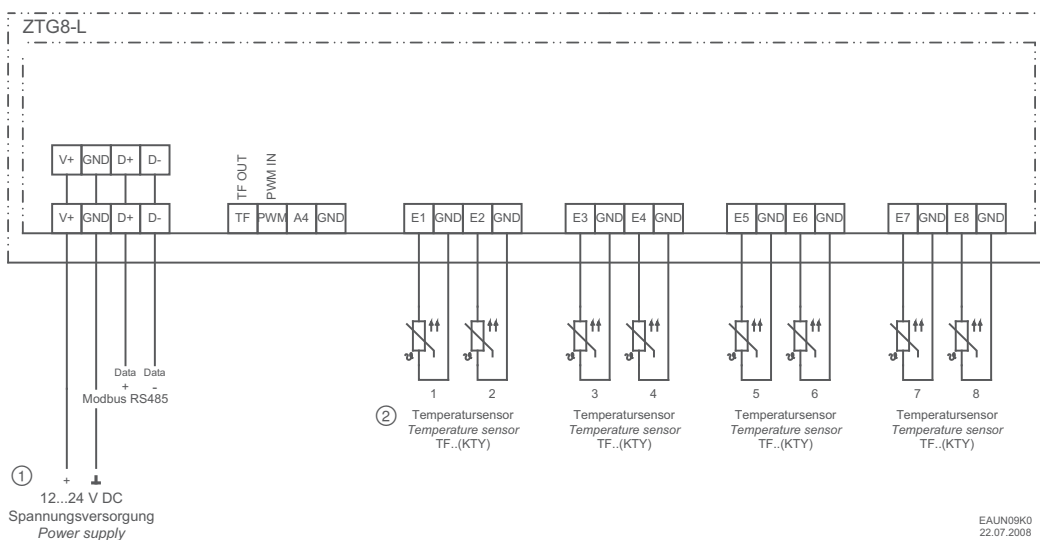

- ① Power supply 12...24 V DC
- ② Temperature sensors 1-8

Motor protection units

For monitoring thermostats (TB)



Complete motor protection is implemented by connecting the thermostat, which is integrated into the motor, to the motor protection unit. Most ZIEHL-ABEGG external rotor motors are equipped with thermostats (TB) in the winding. These thermostats open during high winding temperatures, facilitating the direct monitoring of the temperature in the motor, thus ensuring the direct protection of the motor. When the thermostat opens, the motor protection unit is triggered and has to be manually reset; this is done to prevent an unwanted reconnection after the motor has cooled off.

Additional functions of the 3~ STDT motor protection units: They have an overcurrent trigger integrated. That means the device acts like a fuse and can be used for "current distribution". The adjustable overcurrent trigger protects the cable leading to the connected motors. Dual terminals located on the input and output sides of the motor protection unit facilitate simple wiring of multiple motors or fans on the output side of a powerful controller.

Connection diagram S-ET

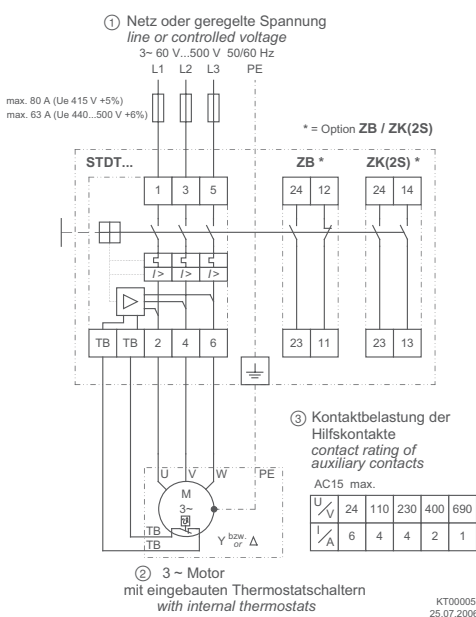

- ① Line or controlled voltage
- ② 1~ motor with integrated thermostats
- ③ Contact load of auxiliary contacts

* Option ZB/ZK(2S)

Connection diagram STDT

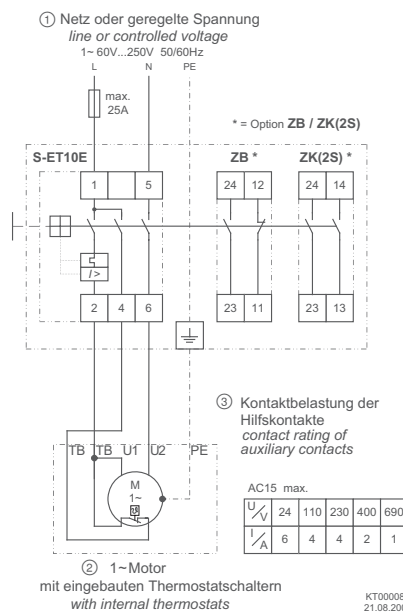

- ① Line or controlled voltage
- ② 3~ motor with integrated thermostats
- ③ Contact load of auxiliary contacts

* Option ZB/ZK(2S)



Equipment/Characteristics

Complete motor protection

Automatic shut-off when connected thermostat „TB“ opens (direct temperature monitoring in the motor winding).

Integrated button

Switch connected motors on and off manually. Manual reset after motor fault (protection from unwanted restarting)

Optional: operating status contact

Type „ZB“ with one open contact and one close contact
Type „ZK“ with two close contacts

Optional padlock feature

Type „Zrep“ for the IP55 housing version. The motor protection unit can be locked during servicing (max. 3 locks)

Cable protection (only in 3~ STDT devices)

Via integrated overcurrent trigger, which can be adjusted to the cable cross section.

Accessories

Type	Article no.	Weight kg
ZB	382013	0.03
ZK	382022	0.03
Zrep	382025	0.11

Motor protection units for monitoring thermostats (TB)

Line	Installation	Type	Article no.	Rated current A	Overcurrent trigger	Minimum ambient temperature °C	Maximum ambient temperature °C	Protection class	Weight kg	Dimensions (W x H x D) mm
1~ 60...250V 50/60Hz	Rail according to EN 60715	S-ET10E	382021	10		-25	55	IP20	0.17	45 x 80 x 85.5
1~ 60...250V 50/60Hz	Wall mounting	S-ET10	382020	10		-25	40	IP55	0.44	80 x 150 x 97.5
3~ 60...500V 50/60Hz	Rail according to EN 60715	STDT16E	382012	16	Overcurrent 10...16 A	-25	55	IP20	0.33	54 x 80 x 85.5
3~ 60...500V 50/60Hz		STDT25E	382015	25	Overcurrent 20...25 A	-25	55		0.50	
3~ 60...500V 50/60Hz	Wall mounting	STDT16	382011	16	Overcurrent 10...16 A	-25	40	IP55	0.60	80 x 150 x 97.5
3~ 60...500V 50/60Hz		STDT25	382014	25	Overcurrent 20...25 A	-25	40		0.75	

Application example

Motor protection units S-ET or STDT, depending on the line. With S-ET monitoring of individual fans, with STDT monitoring of several fans per motor protection unit possible. Thermostats are wired in series.

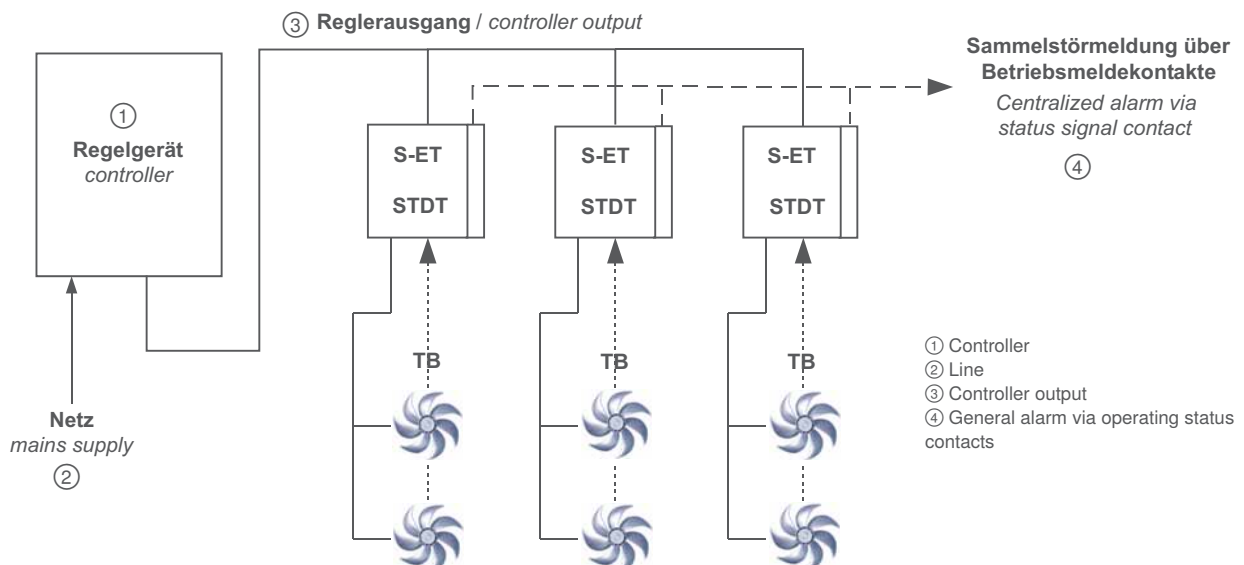

Main switch with bypass function

Controlled operation and 100% operation



The main switches have three switch positions. In position 1 or Auto a connected frequency inverter is supplied. The controlled output of the frequency inverter goes back to the switch which uses it to supply fans for example. 100% or bypass means that the connected mains supply is switched directly to fans or motors. This enables 100% operation in certain situations, for example, emergency operation. An integrated auxiliary contact reports this switch position. In position 0 or Off this switch can be locked with a padlock. For the combination with frequency inverter without sinefilter, EMC inserts are available which can be inserted into the switches.

Equipment/properties

Versions

For combination with 1~ or 3~ control units (e.g. frequency inverter Control, voltage control units). Mains supply 1~ or 3~.

Optional equipment

EMC retrofit kit

These can be inserted in the switches, for combination with frequency inverter without sine filter. Two shield clips are available for connecting the shielded motor line.

EMC Kit S-D-25 Article No. 349056
EMC Kit S-D-50 Article No. 349057

Main switches

Line	Type	Article no.	Max. line fuse A	Minimum ambient temperature °C	Maximum ambient temperature °C	Protection class	Weight kg	Dimensions (W x H x D) mm
1~ 230V 50/60Hz	S-E-20	349048	25	-25	40	IP65	0.30	90.5 x 90.5 x 139
3~ 690V 50/60Hz	S-D-25	349035	35	-25	40	IP65	0.60	115 x 115 x 163
3~ 690V 50/60Hz	S-D-50	349040	63	-25	40	IP65	1.15	145 x 145 x 188
3~ 500V 50/60Hz	S-D-80	349052	125	-25	40	IP65	4.40	300 x 300 x 253

Application example

A group of fans is controlled by the Fcontrol frequency inverter. The frequency inverter can be bypassed in certain situations, the mains supply is switched directly to the fans in bypass operation.

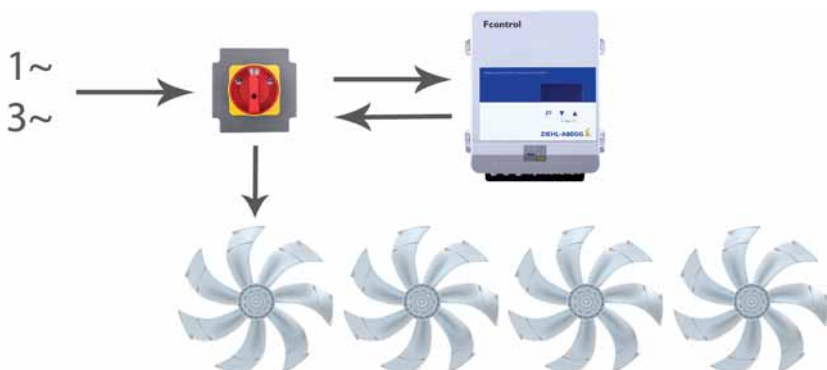

Information

Low pressure

High pressure

System
components

Control
technology

Appendix



Main switch for EC-fans

1~ Zenec with bypass function



Zenec main switch for 1~ EC fans from the ETAvant and ECblue series with 100% function.

EC fans are controlled via an external control signal, e.g. 0 – 10 V. If the control signal drops due to a technical defect, the Zenec can be used to manually switch the connected EC fan to 100 %. To do this, the EC fan must have the control possibility for the 100 % function. ETAvant fans and ECblue for agriculture normally have this function. In livestock farming in particular, this function is very important to ensure ventilation in the animal housing. In addition, the Zenec can suppress the fault indication issued by an external device when the Zenec is switched to the "0" position.

Connection diagram

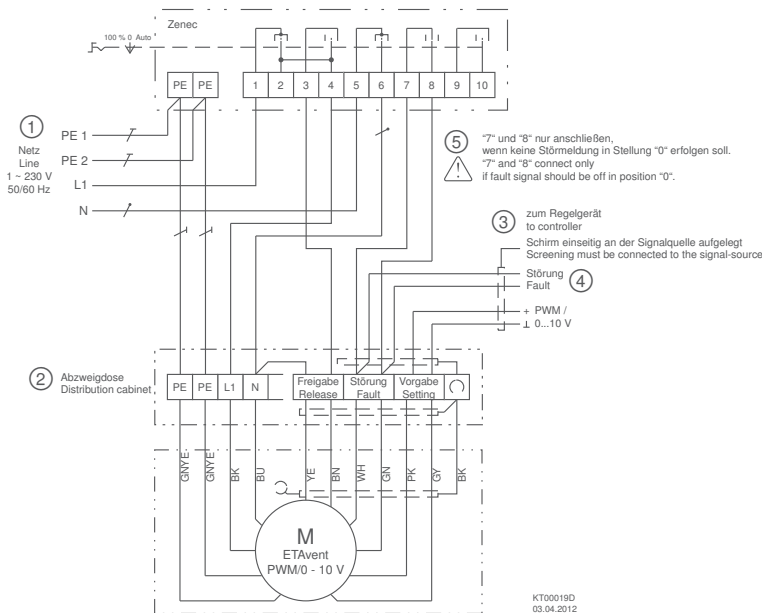

- ① Line 1~ 230 V 50/60 Hz
- ② Distribution cabinet
- ③ To controller
- Screening must be connected to the signal source
- ④ Fault
- ⑤ [7] and [8] connect only if fault indication should be off in position 0

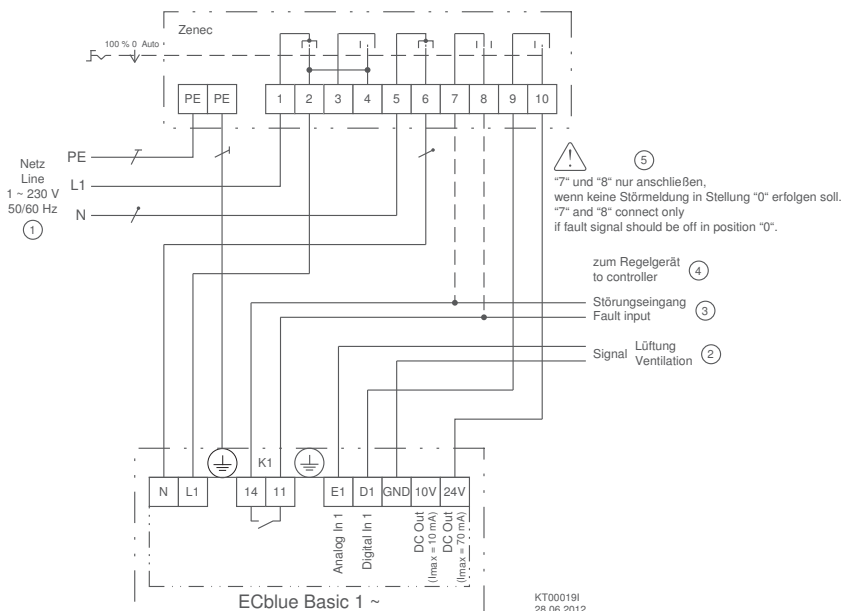

- ① Line 1~ 230 V 50/60 Hz
- ② Signal ventilation
- ③ Fault input
- ④ To controller
- ⑤ [7] and [8] connect only if fault indication should be off in position 0



Equipment / properties

Version

For combination with 1~ EC fans that support the control possibility for the 100 % function: 1~ ETAvent and 1~ ECblue for agriculture.

Switch positions

100 %: Full speed of EC fan

0: Fan switched off. The switch can be locked in this position with a padlock

Auto: Standard operation via external setting signal

Main switches								
1~								
Type	Article no.	Rated current	Max. line fuse	Minimum ambient temperature	Maximum ambient temperature	Protection class	Weight	Dimensions (W x H x D)
		A	A	°C	°C		kg	mm
Zenec	349047	20	25	-25	60	IP65	0.25	90.5 x 90.5 x 107

Information

Low pressure

High pressure

System components

Control technology

Appendix

Sensors

Temperature sensors



TFR



TFW



TFT



TFA



TFK

Different ZIEHL-ABEGG PTC (Positive Temperature Coefficient) thermistors are available. The ZIEHL-ABEGG control unit detects the ambient temperature at the measuring point by the change in resistance in the sensor (KTY81-210). Resistance at 25 °C = 2 kΩ (tolerance 1 %). The polarity can be ignored when connecting.

The temperature measuring range depends on the properties of resolution or programming of the allocated ZIEHL-ABEGG control unit.

The following types of passive thermistors are available:

- Room sensor TFR with plastic box for outdoor or industrial use
- Living room sensor TFW with plastic housing
- Immersed sensor TFT for installation in on-site immersed sleeve
- Plant sensor TFA for pipework
- Duct sensor TFK with housing and sensor rod for air ducts

Alternatively, the active MTG-120V thermistor can be supplied. This consists of a connection housing to which a 2 m long cable with sensor element is firmly connected.

Application possibilities as contact sensor or immersed sensor, e.g. in oil cooler. The MTG... has the measuring range -10 to 120°C and generates 0–10 V proportionally over the measuring range.

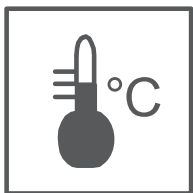

Connections

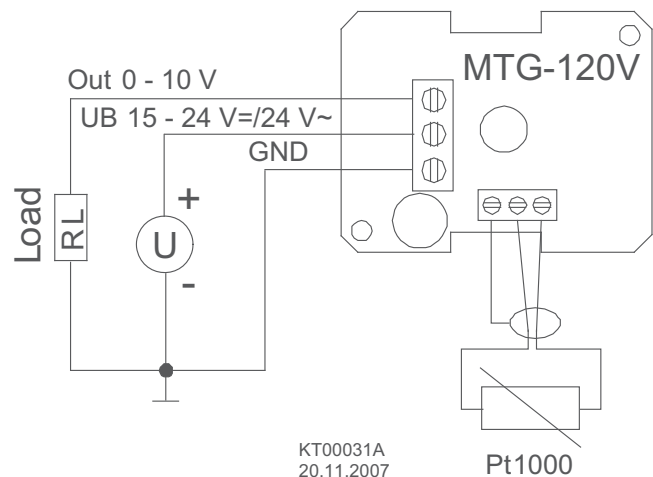
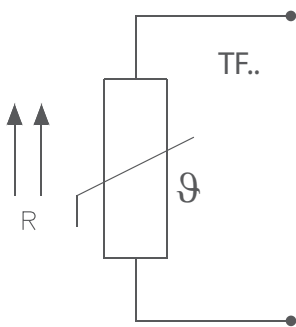

Thermistors „passive“						
Type	Article no.	Protection class	Line/connection	Measuring range	Weight kg	Dimensions (W x H x D) mm
TFR	00089846	IP54		permissible -20...+60 °C	0.05	75 x 75 x 37
TFR-E	00153406			permissible -20...+60 °C	0.00	
TFW	00154798	IP20		permissible -35...+70 °C	0.04	84 x 84 x 23.5
TFT	00154797	IP43	Lead length: ap- prox. 1.9m	permissible -20...+105 °C	0.07	d7 x 50
TFT (XL)	384027	IP43	Lead length: ap- prox. 4m	permissible -20...+105 °C	0.15	
TFA	00153407	IP67	Lead length: ap- prox. 2m	permissible -20...+85 °C	0.03	d6 x 50
TFK	384022	IP65		permissible -50...+120 °C	0.10	

Temperature sensors 15...24VDC/24VAC						
Type	Article no.	Protection class	Line/connection	Measuring range	Weight kg	Output
MTG-120V	384031	IP65 / IP67	Length of sensor cable: approx. 2m	-10...+120 °C	0.15	0...10 V, max. 2 mA

Information

Low pressure

High pressure

System
components

Control
technology

Appendix

Sensors

Combined sensor humidity - temperature

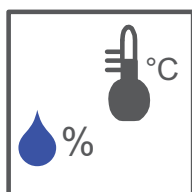

Combined sensor for the exact measurement of relative humidity and temperature, especially suitable for applications in agriculture and air conditioning. Application possibility in polluted atmospheres. The sensor has a connection housing which contains the evaluation electronics.

The relative humidity is output by a 0 – 10 V signal. This corresponds to the measuring range of 0 – 100 % relative humidity. The temperature measurement is made by the change in resistance of the built-in PTC (Positive Temperature Coefficient) element (KTY81-210).

Resistance at 25 °C = 2 kΩ.

Standard conformity

Interference emission according to EN 61000-6-3 (domestic)
Interference immunity according to EN 61000-6-1 (domestic)

Equipment/properties

Measuring range:

Measuring range relative humidity 0 – 100 %

The temperature measuring range depends on the properties or the programming of the allocated ZIEHL-ABEGG control unit.

Protection of the sensor element by stainless steel sinter filter

Combined sensor humidity - temperature

15...35VDC/15...29VAC

Type	Article no.	Minimum ambient temperature °C	Maximum ambient temperature °C	Measuring range	Protection class	Weight kg
MFTG-100V	384033	-40	60	0...100 % r.h.	IP65	0.12

Connections

- ① Spannungsversorgung
Voltage supply
15...35 V DC
15...29 V AC
- ② Ausgang
Output
0...10 V Δ 0...100 % r. F. / r. h.
($I_{max} < 1 \text{ mA}$)

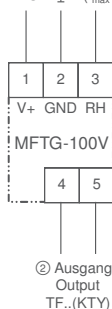

- ① Voltage supply
② Output

KT00016M
19.03.2008



- Information
- Low pressure
- High pressure
- System components
- Control technology**
- Appendix





General notes

Overview

Explanation of technical details	Page 166
Aerodynamics and acoustics	Page 168
Electrical connection and motor	Page 171
Connection diagram	Page 172
Installation and usage information	Page 175

Information

Low pressure

High pressure

System components

Control technology

Appendix

Explanation of technical details

Symbols, Units of Measure

Symbol	Unit	Description
p_{sF}	Pa	Static pressure increase
p_{fd}	Pa	Dynamic pressure
q_v	m ³ /h	Air flow
n_N	min-1	Rated speed
P_1	kW	Input power
P_{sys}	kW	Input power system (including controller)
U_N	V	Rated voltage
f_N	Hz	Rated frequency
I_N	A	Rated current
I_A	A	Starting current
ΔI	%	Percentage increase of current based on rated current for speed control by voltage reduction
C_{400V}	μF	Capacity
$t_{R(min)}$	°C	Minimum permitted ambient temperature
$t_{R(max)}$	°C	Maximum permitted ambient temperature
L_{WA5}	dB(A)	A-rated suction-side sound power level
η_{statA}	%	Overall efficiency, static according to measurement category A at optimum duty point without losses of electronic speed control according to calculation method ErP-commission regulation No. 327/2011 annex II
N_{actual}	-	Actual efficiency grade of the fan based on an electrical input power of 10 kW at its point of optimum energy efficiency
N_{target}	-	Target efficiency grade at motor input power 10 kW
L_{pA}	dB(A)	A-weighted suction-side or pressure-side acoustic pressure level related to a certain measurement distance
P_{spez}	Wh/1000m ³	Specific power

Notes pertaining to the ErP evaluation

The identifier ErP2015 indicates that a fan meets the minimum efficiency factors of the respective level according to the ErP directive or the fan is not subject to the regulations of ErP directive ($P_1 < 125$ W). The actual efficiency in the efficiency optimum of the fan which is used for the ErP evaluation is called η_{statA} . In order to meet ErP requirements, this efficiency must reach a certain minimum value (target energy efficiency). The efficiency N is a parameter in the calculation of the target energy efficiency of the ErP directive. As a reference value for the required efficiency N_{nom} we also specify the actual efficiency N_{act} based on a motor input power of 10 kW. All ErP-relevant data refers to measured data according to measurement category A, which was determined in the long housing from ZIEHL-ABEGG with inlet ring without guard grille, as per ISO 5801.

Size	B	D	D1	R1
200	52	200		13,5
250	85	254	257	10
300	80	306	326	16
315	80	316,5	327	27
350	87	356	367	35
400	100	400	410	35
450	110	451	463	45
500	118	503	517	45
560	135	559	576	45
630	150	634	653	55
710	167	711	728	95
800	195	797	814	100
910	205	914	930	100
1000	205	1000	1016	105
1250	340	1260	1347	105

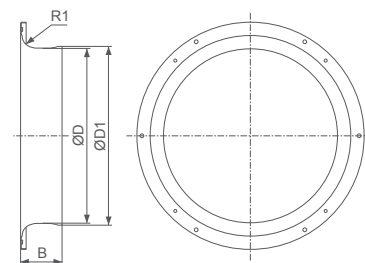

L-KL-3017



Conversion factors

Pressure

		SI-unit	Additional units		
		Pa (N/m ²)	mbar	in.wg	psi (lbs./in ²)
SI-unit	Pa (N/m ²)	1	0.01	0.004015	0.000145
Additional units	mbar	100	1	0.401463	0.014504
	in.wg	249.10	2.49	1	0.036127
	psi (lbs./in ²)	6894.76	68.95	27.68	1

Air flow

		SI-unit	Additional units		
		m ³ /s	m ³ /h	l/s	cfm
SI-unit	m ³ /s	1	3600	1000	2118.9
Additional units	m ³ /h	0.000278	1	0.277778	0.588578
	l/s	0.001	3.6	1	2.1189
	cfm	0.000472	1.699011	0.471947	1

Temperature

		SI-unit	Additional units
		°C	°F
SI-unit	°C	1	(°C × 1,8) + 32
Additional units	°F	(°F – 32) / 1,8	1

Dynamic pressure

Calculation of the dynamic pressure:

$$p_{fd2} = k \cdot q_v^2$$

- p_{fd2} Dynamic pressure at fan outlet in Pa
- k Constant
- q_v Air flow in m³/h

Example:

Type FN050-4EQ.4I.A7P1, Item no. 140084

Size	Constant
020	4,7 · 10 ⁻⁵
025	1,7 · 10 ⁻⁵
030	8,6 · 10 ⁻⁶
031	7,5 · 10 ⁻⁶
035	4,7 · 10 ⁻⁶
040	2,9 · 10 ⁻⁶
042	2,4 · 10 ⁻⁶
045	1,8 · 10 ⁻⁶
050	1,2 · 10⁻⁶
056	7,7 · 10 ⁻⁷
063	4,6 · 10 ⁻⁷
071	2,9 · 10 ⁻⁷
080	1,9 · 10 ⁻⁷
081	1,1 · 10 ⁻⁷
100	7,5 · 10 ⁻⁸
125	3,0 · 10 ⁻⁸

$$p_{fd} = 1,2 \cdot 10^{-6} \cdot q_v^2$$

Aerodynamics and Acoustics

Measurement method

The characteristic map display shows the pressure increase Δp_{sF} in Pa as a function of the volume flow rate q_v in m^3/h .

Technical conditions of supply

The specified performance data meet the requirements for accuracy class 3 in line with **DIN 24 166** and apply to the rated data and air performance curves at the rated voltage. The continuous line in the characteristic map represents the optimum reliable operating range for axial fans.

Fan test bench

The fan characteristic curves are determined on a combined ventilation and sound test bench.

The characteristic curves are measured in compliance with **DIN EN ISO 5801** and **AMCA 210-99**. The sound power levels are measured in compliance with **DIN EN ISO 3745** and **ISO 13347-3** using the enveloping surface measuring method.

The figure below shows an example of the measuring setup. The fan intake is installed in the measuring chamber at free intake and free exhaust (installation type A as per **DIN EN ISO 5801** or **AMCA 210-99**).

Air density

The air density and humidity are conditioned during the measurement using heat exchangers and kept largely constant. The characteristic curves shown refer to the measuring density. The mean measuring density is 1.16 kg/m^3 .

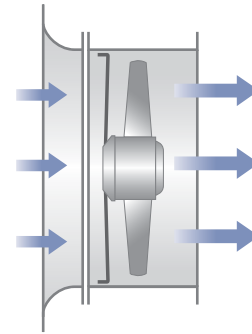

KL-1290a

Installation type A according to ISO 5801



Technology Centre (InVent)

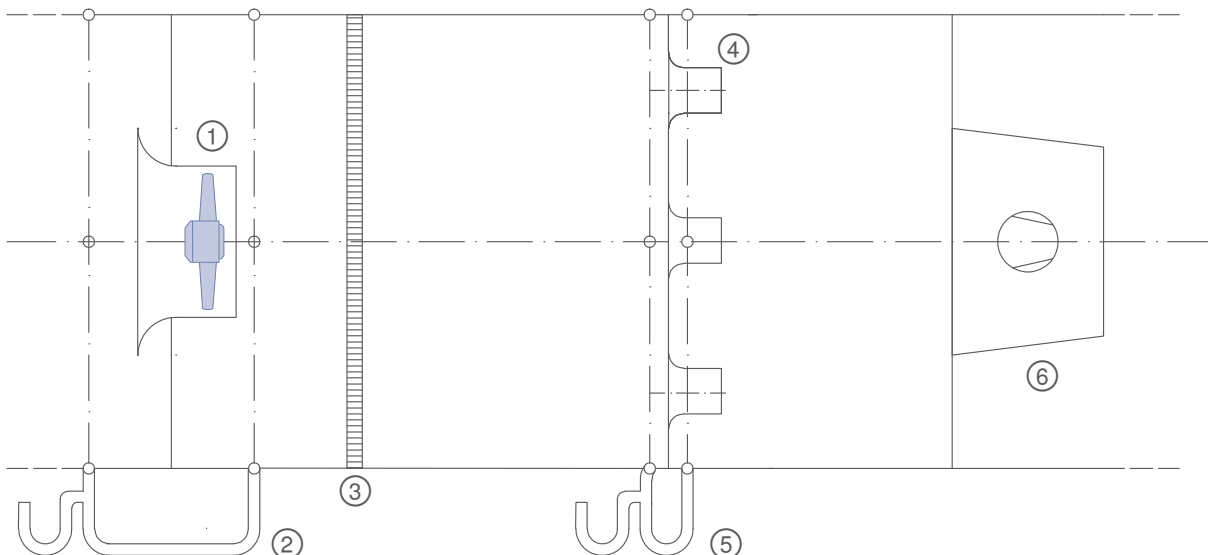

- ① Test fan
- ② p_{sF}
- ③ Flow straightener
- ④ Nozzles
- ⑤ Δp Differential pressure
- ⑥ Auxiliary fan



Noise level data

Unless otherwise indicated, this catalogue specifies the intake side, A-weighted acoustic power levels L_{pA} at a distance of 7m, whose value is calculated from the acoustic power level. The sound power levels are determined by using the enveloping surface method in compliance with **ISO 13347-3**, accuracy class 1 and/or **DIN EN ISO 3745**.

This is done by measuring the acoustic pressure level L_p of the individual third-octave bands at 12 points on the enveloping surface (Fig. 1a). The measured acoustic pressure levels for the third-octave bands are initially used to calculate the sound power level for the third-octave bands and then the intake side sound power level L_{wS} . To do this, the fans are installed with a free intake (from the measuring chamber) and (air) outlet (into the surrounding area). The standard measurements are carried out without the need for additional parts, e.g. guard grille. The measuring equipment used complies with **DIN EN 61672**.

Because of the different weighting of the third-octave sound power level, the A-evaluation, which is typically carried out, takes into account the subjective nature of human sound perception. The A-tested sound power level is the standard variable used to assess the sound characteristics of technical equipment.

Calculation of pressure side sound power level and total sound power level

For axial fans, the pressure side sound power level is approximately equal to the intake side level. The total sound power level is calculated by adding up the power from the sound power levels of both the intake and the pressure side (see **DIN 45 635 Part 1, Appendix F, DIN EN ISO 3745**). Thus, it is approximately 3 dB higher than the intake side sound power level specified in the catalogue.

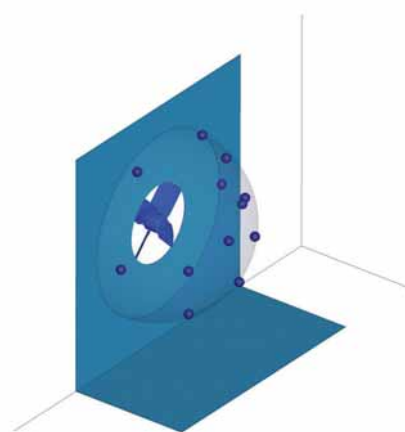

Fig.1a: Position of microphones in relation to axial fans

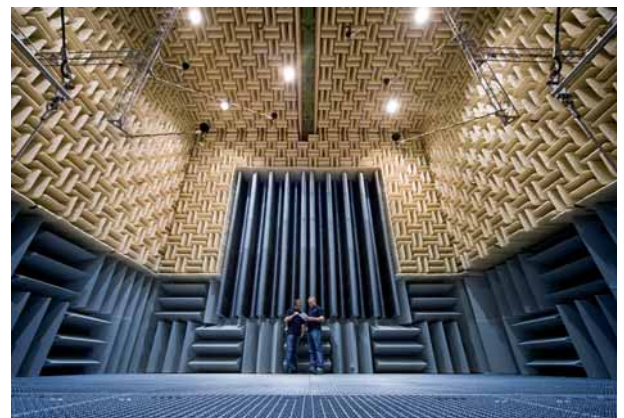

Fig. 1b: Fan test-bench

Determination of total sound power level during the interaction of several sound sources

The total sound power level of several individual sound sources operating concurrently is calculated by adding the power of the individual levels in compliance with **DIN EN ISO 3745**. This equation is the basis for the diagrams in Fig. II and III.

To add up several sound sources with the same level, please see diagram (Fig. II) for complete level information; e.g. 6 identical sound sources operating concurrently results in a total level that is approx. 8 dB higher.

The total sound power level of two sound sources with different levels can be seen in diagram Fig. III. For example, two sound sources whose sound power levels differ by 4 dB produce a total sound power level that is around 1.5 dB higher than that of the louder sound source.

Determination of acoustic pressure level

The A-tested acoustic pressure level L_{pA} for rooms with average absorption capacity for a distance of 1 m from the fan axis is calculated by subtracting 7 dB from the A sound power level L_{WA} . In most cases, this assumption is correct and provides a sufficient level of accuracy. However, the sound characteristics can be hugely influenced by the individual installation situation. Absorption of the acoustic pressure level, depending on the distance with partial reflection, is shown in Fig. IV.

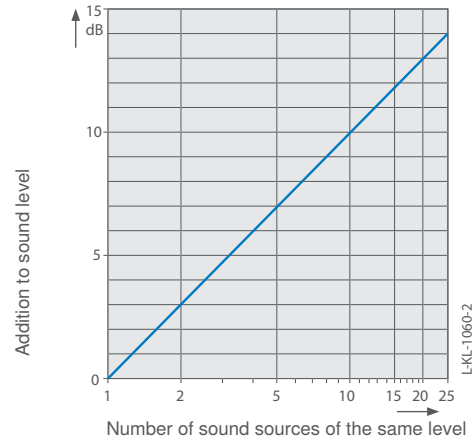

Fig. II: Addition of several sound sources

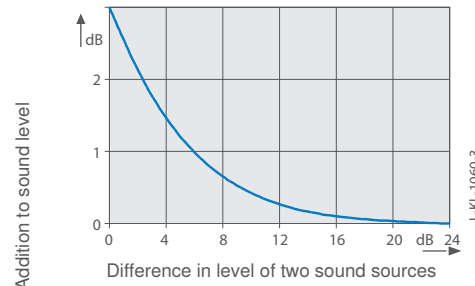

Fig. III: Sound sources of different levels

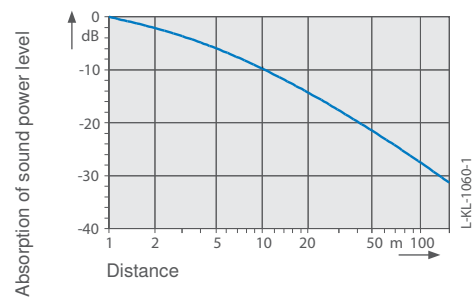

Fig. IV: Reduction of sound pressure level



Electrical connection and motor

Fan drive

The three-phase or single-phase AC external rotor motor integrated into the fan hub meets the requirements for circulating electrical machines set out in **DIN EN 60 034-1** (VDE 0530 Part 1).

AC technology:

The rated voltage for three-phase current is 400 V, for single-phase AC motors 230 V.

EC technology:

The axial fans are powered by a highly efficient EC motor with integrated commutation electronics. Depending on the version, the ECblue motors have a broad voltage range.

1~ 200-277 V, 50/60 Hz

3~ 200-240 V, 50/60 Hz

3~ 380-480 V, 50/60 Hz

Operation on the frequency inverter

ZIEHL-ABEGG axial fans are suitable for operation with frequency inverters, however, the following has to be observed:

All-pole active sinefilters between the inverter and the motor (sinusoidal output voltage! Must be installed phase to phase, phase to PE conductor) as supplied by some inverter manufacturers. For more details please request our technical information sheet L-TI-0510.

du/dt filters (also known as motor or attenuation filters) may not be used instead of sinefilters.

When using sinefilters, it may no longer be necessary to use screened motor power cables, metal terminal boxes, or a second earth connection on the motor (please consult your sinefilter supplier).

Electrical connection

Voltage

The single-phase or three-phase AC motors are suitable for 400 V or 230 V and are continuously voltage controllable. Please pay attention to the data sheet.

Current

Motor current is dependent on the installation (i.e. flow situation and nozzle) and operation (i.e. operating point in connection with air density). For the definition of electrical installations, the following value is recommended: $I_{max} = I_N + \Delta I + \approx 30\%$

Motor connection

Mains connection via terminal box or connecting cable implemented as per dimensional drawings. Cable length tolerance ± 3 cm.

Terminal box

Terminal boxes are made of impact resistant and weather resistant plastic or die-cast aluminium.

All terminal boxes have two M20x1.5 cable inlets.

For FE2owlet and FE2owlet-ECblue axial fans in F design without guard grille, the terminal box is located on the outside on the flange ring. In the F design with guard grille, the terminal box is mounted on the front on the motor.

Connection cable

Heat and UV resistant halogen-free hose cables are used, marked by a colour code or connection designations.

The cable construction complies with VDE 0282 part 804 and is suitable for operating voltages of up to 690 V.

Temperature resistance -50 to +150°C.

The ends of the connection are stripped for 10 cm and fitted with wire end ferrules.

Service capacitor

See system components chapter.

Connection diagrams

1360-403 (EC116 / EC152)

EC-Technology

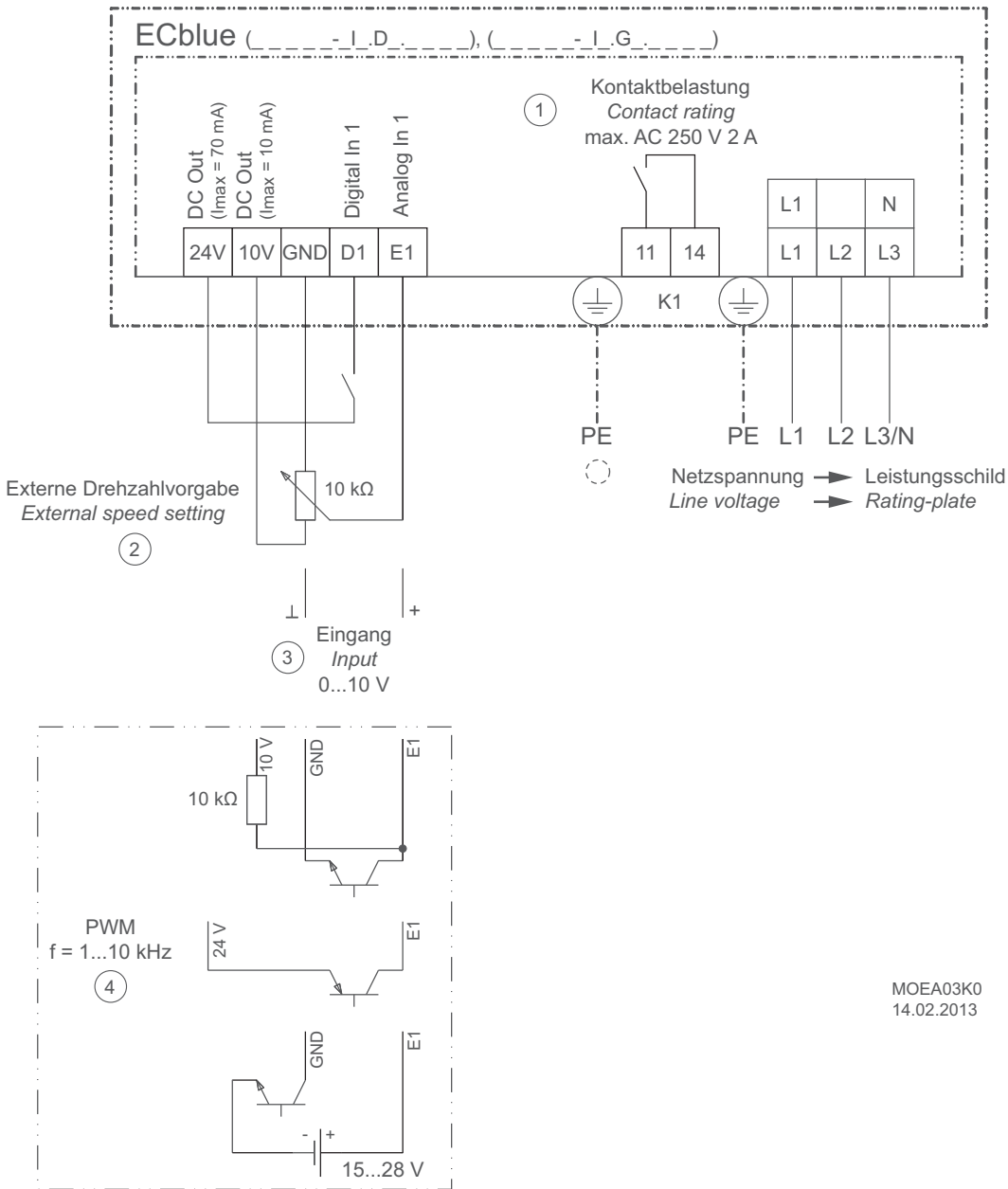

MOEA03K0
 14.02.2013

- ① Contact rating
- ② External speed setting
- ③ Input
- ④ PWM

1360-389

EC-Technology

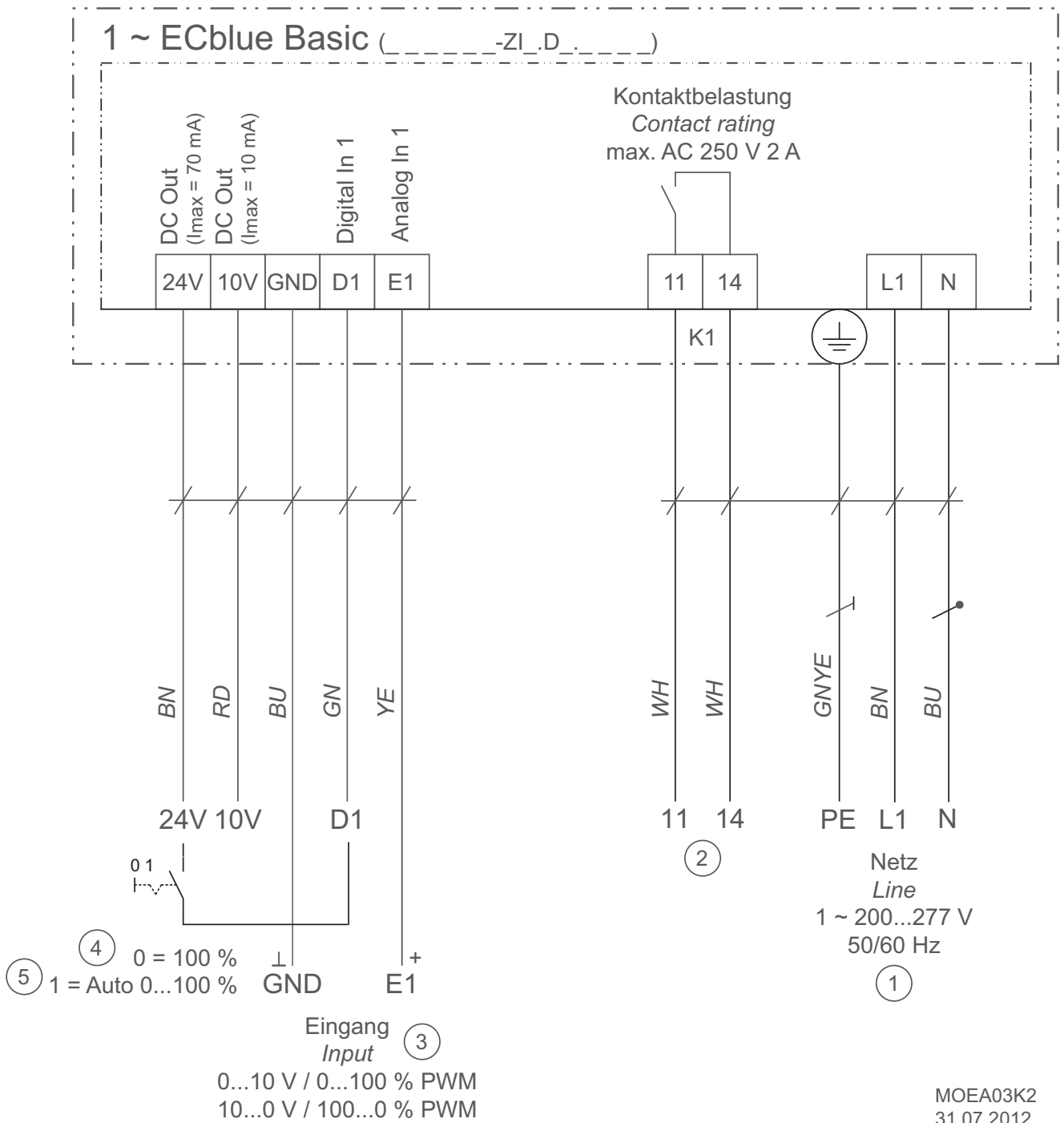

- ① Line voltage 1 ~ 200...277 V, 50/60 Hz
- ② Relay connection, max. contact rating AC 250 V 2 A
- ③ Input 0...10 V, 0...100 % PWM
- ④ 0 = Contact open, full fan speed
- ⑤ 1 = Contact closed, automatic speed control via 0 - 10 V signal

MOEA03K2
31.07.2012

Connection diagrams

AC-Technology

104XA

For 1~ motor with capacitor and thermostats (if installed).

Airflow direction: V

Rotat. direction: Right hand rotation

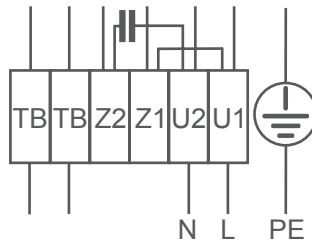

Cable colours:

U1 brown
U2 blue
Z1 black
Z2 orange
TB white

104XB

For 1~ motor with capacitor and thermostats (if installed).

Airflow direction: A

Rotat. direction: Left hand rotation

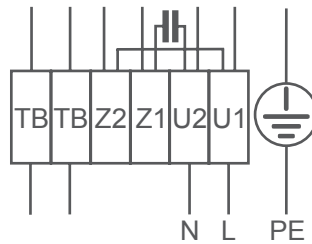

Cable colours:

U1 brown
U2 blue
Z1 black
Z2 orange
TB white

106XA

For 3~ motor with capacitor and thermostats (if installed).

Airflow direction: V

Rotat. direction: Right hand rotation

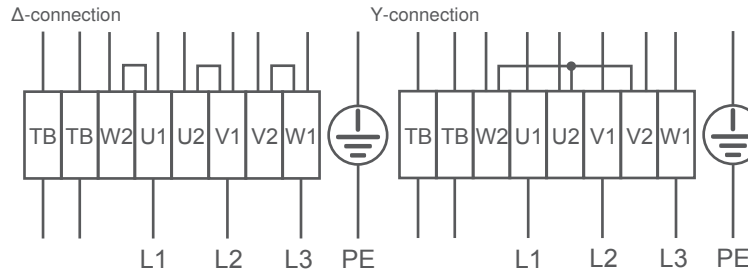

Cable colours:

U1 brown
V1 blue
W1 black
U2 red
V2 grey
W2 orange
TB white

106XB

For 3~ motor with capacitor and thermostats (if installed).

Airflow direction: A

Rotat. direction: Left hand rotation

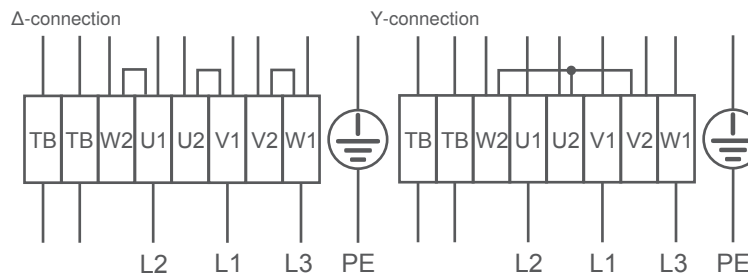

Cable colours:

U1 brown
V1 blue
W1 black
U2 red
V2 grey
W2 orange
TB white

108XB

For 3~ motor with 2 speeds (Δ -/Y switching) and thermostats (if installed).

Without bridge if using speed switch.

Airflow direction: A

Rotat. direction: Left hand rotation

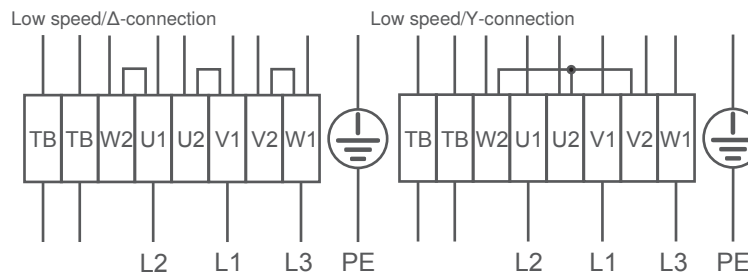

Cable colours:

U1 brown
V1 blue
W1 black
U2 red
V2 grey
W2 orange
TB white

123XB

Für 1~ Steinmetz-Motor mit Kondensator und Thermostatschalter (falls eingebaut).

Luftförderrichtung: A

Drehrichtung: Linkslauf

Anschlusschaltbild im Anschlusskasten bitte aufbewahren.

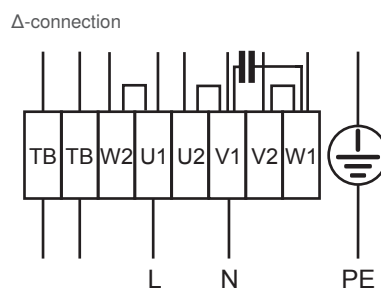

Kabelfarben:

U1 braun
V1 blau
W1 schwarz
U2 rot
V2 grau
W2 orange
TB weiß



Installation and usage information

Materials and corrosion protection

Axial fans in agriculture have an impeller made of high performance composite material or aluminium.

Rotor and stator flange are made of sea water resistant aluminium alloy using a die-casting method.

The fan nozzles are made depending on the application of hot-dipped thin sheet or composite material. ZPlus nozzles consist of high performance composite material.

Additional painting possible upon request and at an extra charge.

Depending on the fan size, motor suspensions are produced as wire support grids or a welded structure with flat steel struts.

The wire carrying grille and welded structure with flat steel struts are provided with weather resistant plastic coating.

Notify us of the area of application subject to increased climatic stress or use in wet rooms such as breweries, dairies or similar.

Installation position

The axial fans are suitable in agriculture for the installation positions H and Vo.

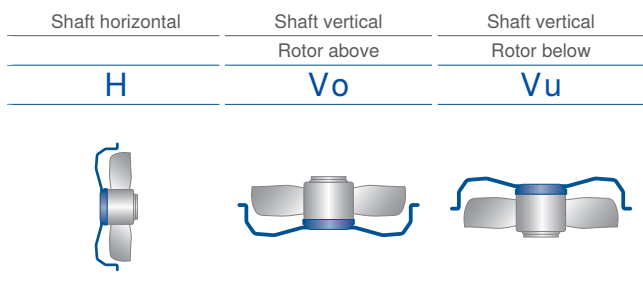

Luftförderrichtung

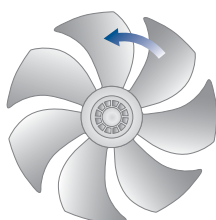

KL2065

Direction of rotation counter clockwise
looking at the rotor

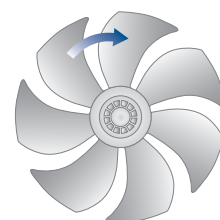

KL2064

Direction of rotation clockwise
looking at the rotor

Conditions for use and lifetime

Protective device

The fans may only be operated if installed appropriately for their purpose and when safety is ensured through protective devices as per **DIN EN 13857** or **ISO 13852 (DIN EN ISO 12100)** or by other construction protection measures.

Condensation holes

According to the installation position V_o (rotor upwards) or V_u (rotor downwards), the condensation hole beneath must be open. In installation position H, condensation can flow through the seal gap between the stator and the rotor.

Operating mode

Continuous operation with occasional starts (S1) according to **DIN EN 60034-1:2011-02**. If the defined temperature $t_{(R(min))}$ of the product is less than -25 °C an occasional starting between -25 °C and the defined minimum temperature is permissible. Continuous operation below -25 °C only with special bearings for refrigeration applications on request.

Permissible minimum and maximum ambient temperature for operation

Please refer to the technical documentation of the product for the minimum and maximum ambient temperature valid for the respective fan. Operation below -25 °C as well as partial load operation for refrigeration applications is only possible with special bearings for refrigeration applications on request. If special bearings for refrigeration applications are installed in the fan, please observe the permissible maximum temperatures in the technical documentation of the product.

Ball-bearing service life

The according to standard calculation methods determined bearing service life expectation of the motor-integrated ball bearings is mainly determined by the grease service life F10h and amounts for standard application to approx. 30.000 – 40.000 operating hours. The fan is maintenance-free due to the use of ball bearings with „lifetime lubrication“. Once the grease operating life F10h has been reached, it may be necessary to replace the bearing. The bearing service life expectation may change compared to the specified value, if operating conditions such as increased vibrations or shocks, increased or too low temperatures, humidity, dirt in the ball bearing or unfavourable control modes are present. A service life calculation for special applications can be provided on request.

Waste air purification systems

The high pressure fans are designed for use in (pressure-side) waste air purification systems among other things. Special attention must be paid to ensure that the fan does not come into contact with any chemicals used, as these usually have a highly corrosive effect. In such cases, the product service life can be considerably reduced.



Guard grille

A guard grille can be included in the scope of delivery if the fan includes a motor suspension or motor suspension with wall ring. The guard grille is on the suction or pressure side of the fan, depending on airflow direction.

The chapter on system components contains separate guard grilles, which can be installed on the exhaust or suction sides of the fan as required, depending on installation position and complying with the safety requirements as per **DIN EN ISO 13857:2008 (tab.4)**. Please observe the section "Influence of guard grilles".



Axial fan FF, design Q

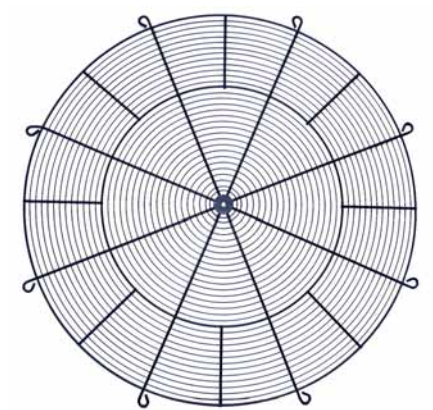

Guard grille system component, blow out side

Influence on guard grille

Safety distances to prevent danger zones from being reached

The **DIN EN ISO 13857** standard specifies the safety distances to prevent the upper limbs from getting into danger zones.

The preferred "protective construction" used on axial fans is a guard grille. The vast majority of our axial fans (S, K, D, W, Q designs) are equipped with a screen protection integrated into the suspension as standard. For fan types that have suspension with no integrated guard grille, a separate guard grille is available as an accessory. The guard grille results in a resistance to the conveyed airflow, which manifests itself in the pressure loss Δp_{VG} . The pressure loss Δp_{VG} increases in a linear relationship with a coefficient of resistance ζ_G or quadratically with the conveyed volume flow rate q_v .

$$\Delta p_{VG} = \zeta_G \cdot \frac{\rho}{2} \cdot \frac{16 \cdot q_v^2}{\pi^2 \cdot d_n^4}$$

The coefficient of resistance ζ_G is largely determined by the screen design (mesh size, ring spacing), which is stipulated by the **DIN EN ISO 13857** standard. The coefficient of resistance for the ZIEHL-ABEGG guard grilles obtained in series of tests on FC series fans lies in the range $\zeta_G = 0.2-0.4$. This covers the suction-side and exhaust-side installation of the guard grille. The following numerical equation provides an approximate estimate of the pressure loss from the guard grille in [Pa]:

$$\Delta p_{VG} = K_{VG} \times 10^{-8} \times q_v^2$$

The loss factor K_{VG} can be read from the above diagram depending on the nominal fan diameter d_n . The volume flow rate q_v is inserted in [m³/h].

Note:

FANselect selection program supplies all characteristic curves, also including the influence of the guard grille. See <http://www.fanselect.net/>.

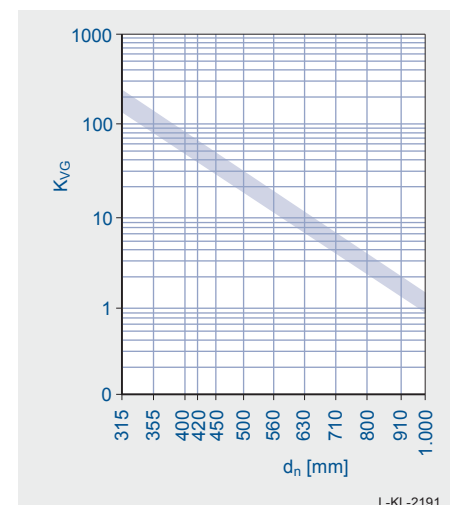

Factor for loss attributable to the grating K_{VG} as a function of the nominal diameter d_n of the fan

Installation instructions chimney installation

Chimney installation

The T design can be installed directly in the chimney using fixing brackets. A distance equal to the diameter must be kept to the inlet ring or rear edge of the opened shutter and to the exhaust or diffuser.

A 650mm chimney guide vane can be delivered to improve the exhaust air plume.

Installation in full bell mouth

With the full bell mouth, the fan can be installed directly to the ceiling of the chimney's inlet or in a wall. The full bell mouth is made from composite material or galvanized sheet steel. At the same time, the full bell mouth offers the best protection to the fan against handling damage.

Guard grilles are available in system components.



Source: DLG test report



What makes ZPlus special?

ZPlus nozzle

If high energy efficiency and low operating costs play an important role.

- High-performance composite material
 - No corrosion
 - UV-resistant
- Optimised nozzle
 - Maximum efficiency
- Diffusor (short diffusor)
 - Efficiency increase in the case of low pressures
- Guide blades
 - Efficiency increase in the case of high pressures

It can be used in an operational area between -40 °C^{***} and $+80\text{ °C}$.

******* Continuous operation with occasional starts (S1) according to **DIN EN 60034-1:2011-02**. Occasional starting between -40 °C and -25 °C is permissible. Continuous operation below -25 °C only with special bearings for refrigeration applications on request.

ZPlus features a flange on both sides. This means it can be installed extremely flexibly, either on the suction or pressure side. Guard grilles for the suction/pressure side are available in the chapter on system components.

Possible installation position:
Shaft horizontal (H) or rotor on top (Vo)



Installation instructions

Airflow conditions

When installing fans in the devices, favourable airflow conditions must be maintained; this also applies to compact designs.

The following installation recommendations (Fig. I and II) indicate the required minimum distances.

Fig. I free air intake, connected to outlet side

Fig. II free air outlet, connected to intake side

Fig. III Air inlet nozzles

Please observe recommended gap s between fan blade and inner edge of nozzle.

Fig. IV Influence of nozzle shape, comparison of characteristic curves (Fig. IV)

- ① Full nozzle (Design Q)
- ② Short nozzle, see Accessories

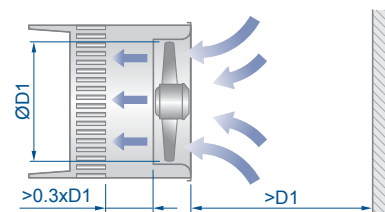

Fig. I

L-KL-2508

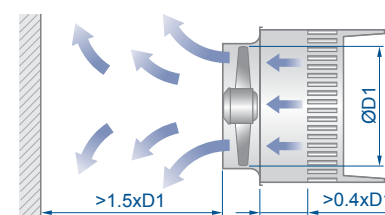

Fig. II

L-KL-2508/1

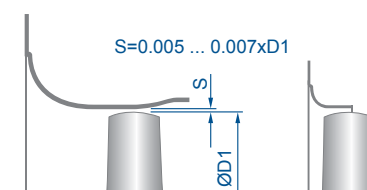

Fig. III

L-KL-2507

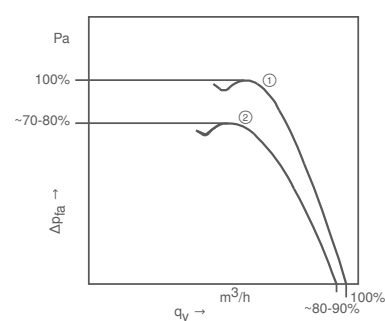

Fig. IV

KL2022



Installation / application examples

Fan-design FB_ _ _ - _ _ K

- ① Fan mounting plate with short bell mouth
- ② Axial fan for refrigerant technology

Space saving construction due to the mounting plate with short bell mouth. Performance can be reduced by using a short bell mouth.

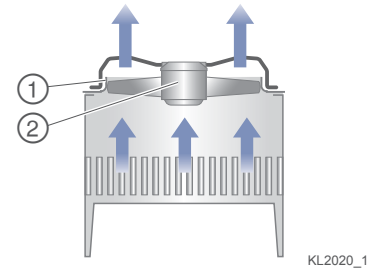

Example: Application with short nozzle for refrigeration

Fan-design FN_ _ _ - _ _ Q

- ① Wall plate or fan mounting plate with full bell mouth
- ② Axial fan for refrigerant technology

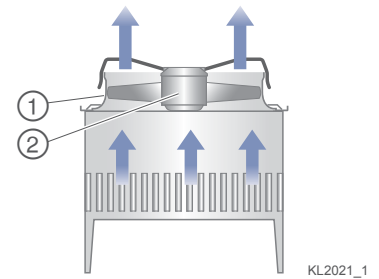

Example: Application with full nozzle for refrigeration

Fan-design FN_ _ _ - _ _ W

- ① Fan mounting plate
- ② Axial fan for heating technology

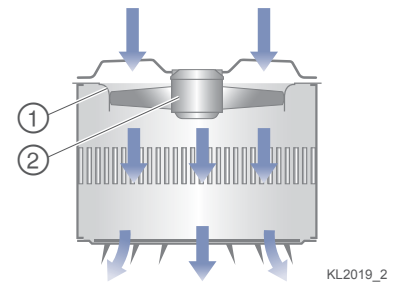

Example: Application with short nozzle for air heater

Usage examples



Small refrigeration units with ZIEHL-ABEGG fans



Condenser with axial fans



Condenser with axial fans

General notes

The information and data contained in this catalogue were composed to the best of our best ability and do not absolve the user from its duty to check the suitability of the products with respect to its intended application.

ZIEHL-ABEGG SE reserves the right to make design changes, which are used for continuous technical improvement.

The customer is obligated to inform the supplier about general information concerning the intended use, the type of installation, the operating conditions and any other conditions that need to be taken into consideration if the order is not based on catalogue information.

Copyright

ZIEHL-ABEGG SE reserves in its entirety the copyright of this catalogue. The catalogue is intended for proper use as intended and neither the catalogue, its content nor extracts may be passed on to third parties without our express written consent.





The Royal League



© ZIEHL-ABEGG SE - 00703826 - EN - MA - 03/2016 - 2.000 - Schweikert - Subject to technical modifications